

Marble Run 003 4-Ways Standard v1 Plus

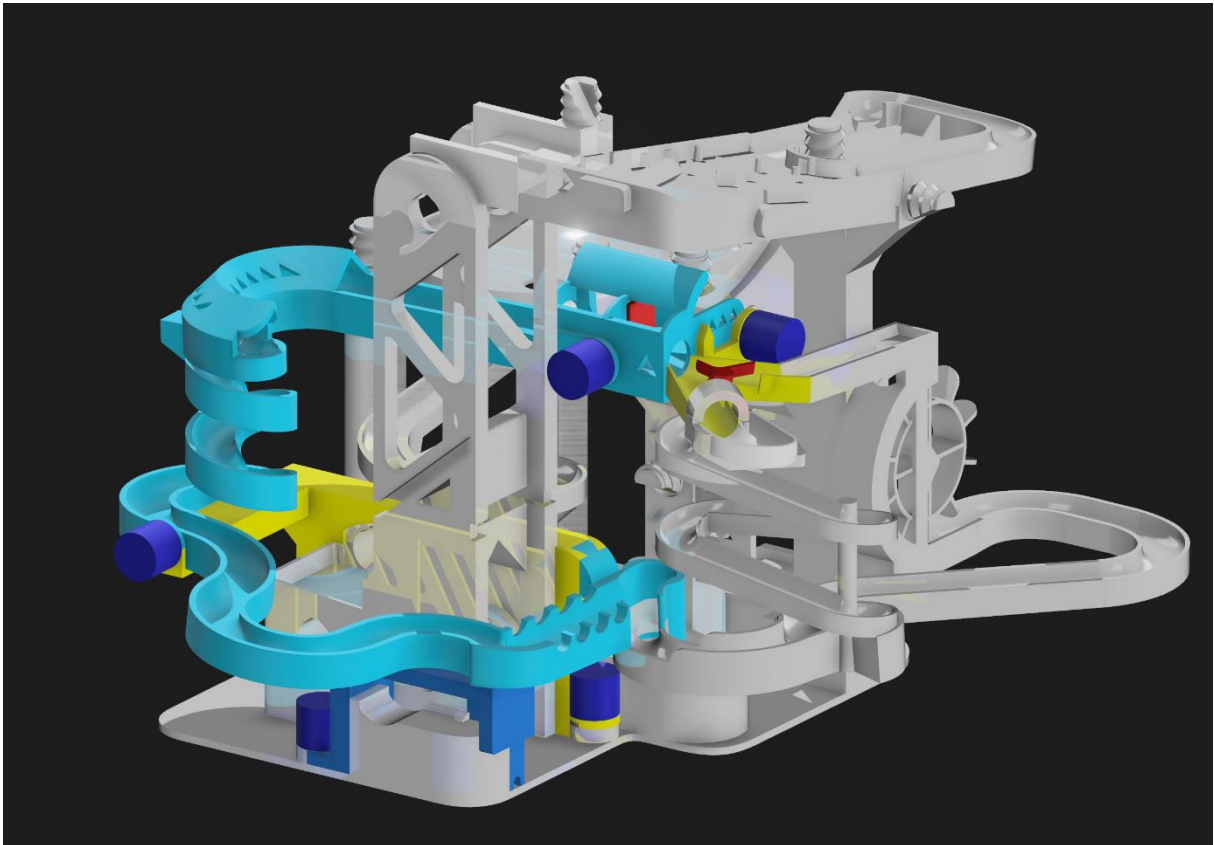

Marble Run 003 4-Ways Standard v1 Plus is another Addon and expands the Paddle Wheel v2 Plus Addon by a fourth way.

It is therefore necessary to have the addon <https://makerworld.com/en/models/419236> first.

Print parts:

1x Motor Protection with Cable Management (**OPTIONAL***)
1x Connector (**OPTIONAL**)
1x Track Mount A
1x Track Mount B
1x 4-Ways Jump Catcher
1x Slider
1x J-Pipe
1x Helix
1x Serpentine
1x 4-Ways Fork
1x Fork Cross
2x Screw nuts

No. 1
No. 2
No. 3
No. 4
No. 5
No. 6
No. 7
No. 8
No. 9
No. 10
No. 11
No. 12, 13

Support required:

yes
no
yes
yes
yes
no
no
yes
yes
yes
no
no

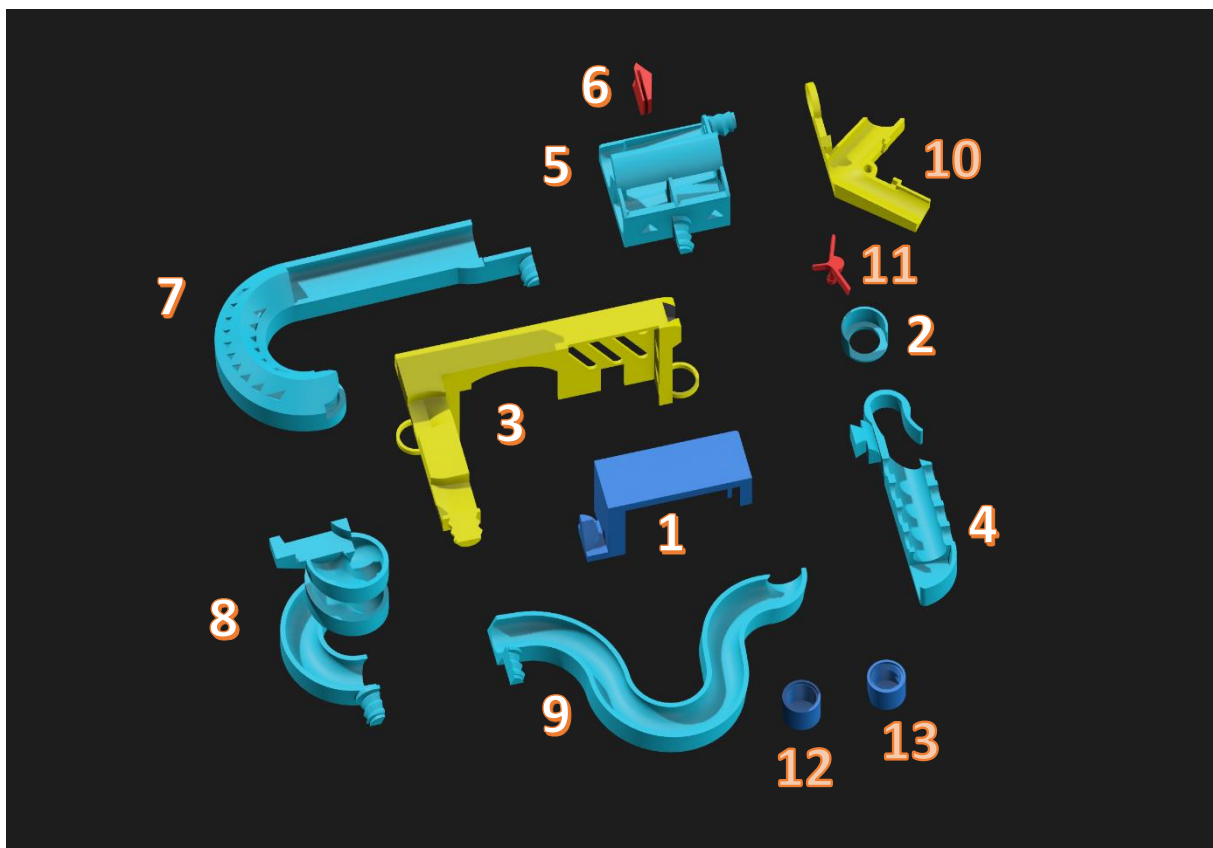

*The original motor case can still be used. This version includes better cable management.

Filament:

PLA

Print instructions:

The use of the Print Profile is recommended. The configuration settings (esp. supports and orientation) on the build plates are different for each part and have been tested several times. Of course, feel free to select your own colours.

Assembly:

1. **OPTIONAL:** Replace original Motor Case by Motor Protection with Cable Management (No.1). This version includes better cable management, but the original motor case can still be used with this add-on.

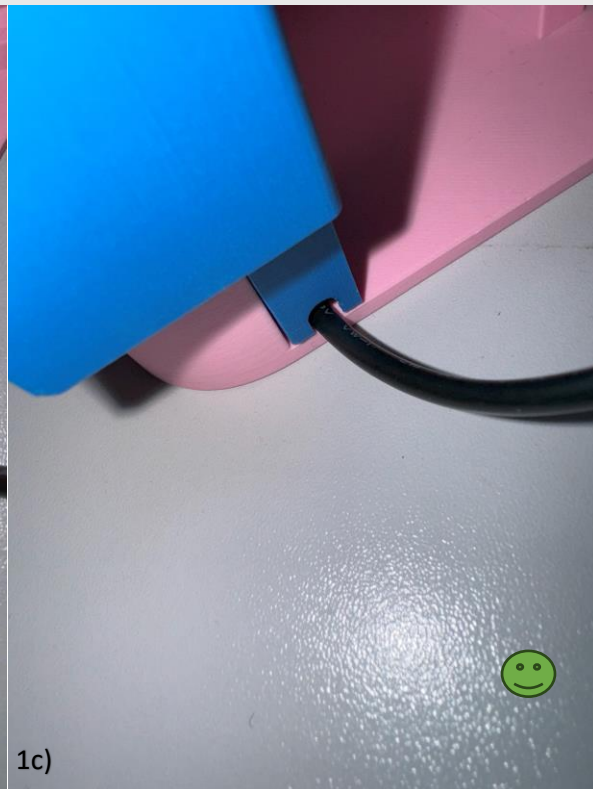
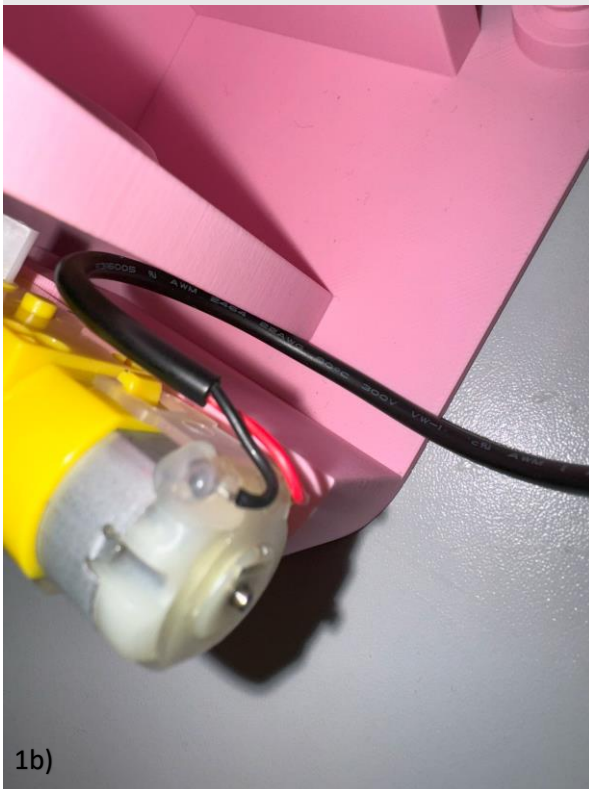
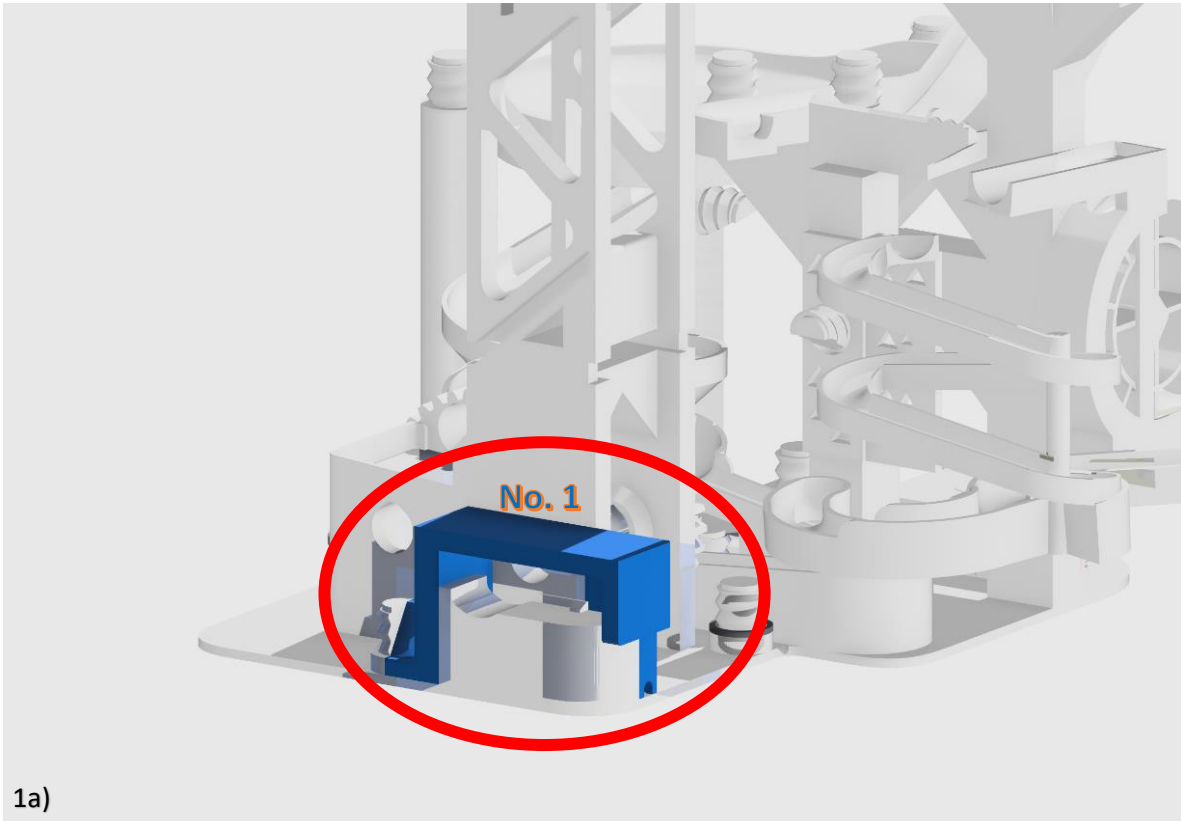

2. **OPTIONAL:** If not already done when assembling **Paddle Wheel v2 Plus Addon**, connect the Connector (No.2) to the serpentine of Paddle Wheel v2 Plus.

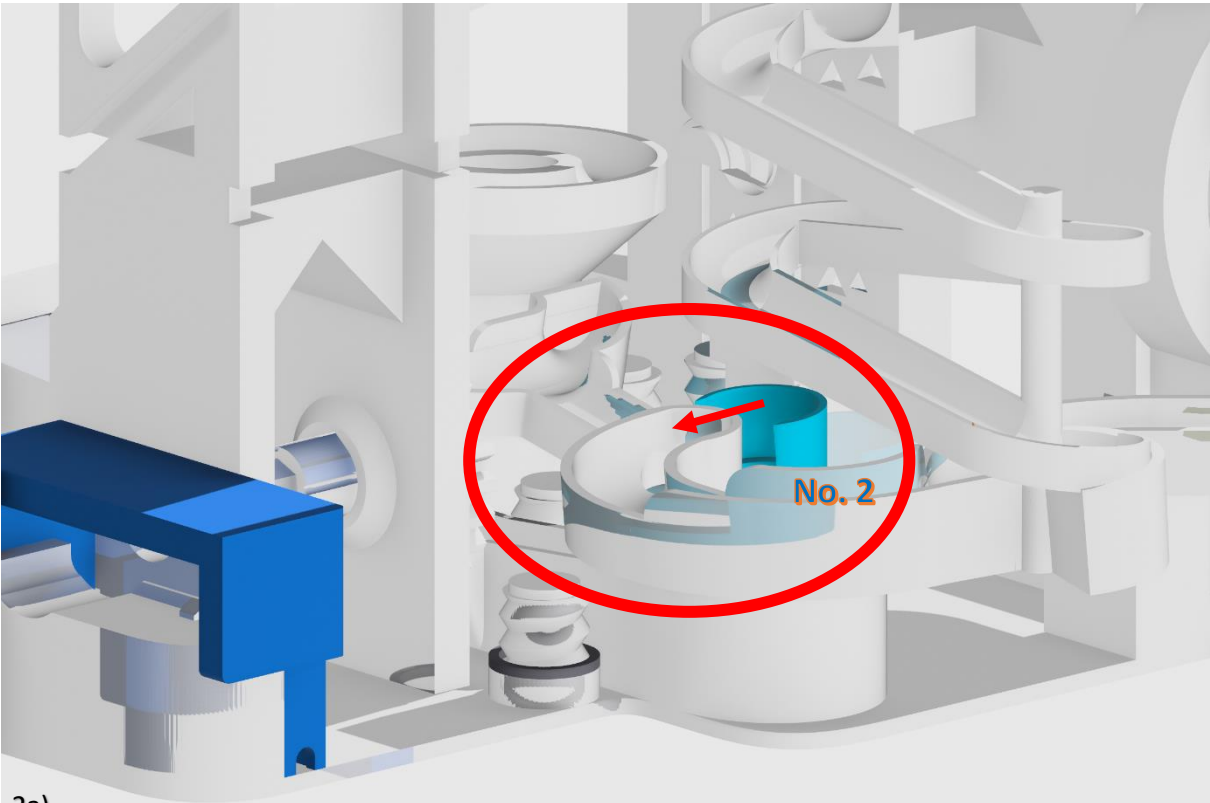

2a)

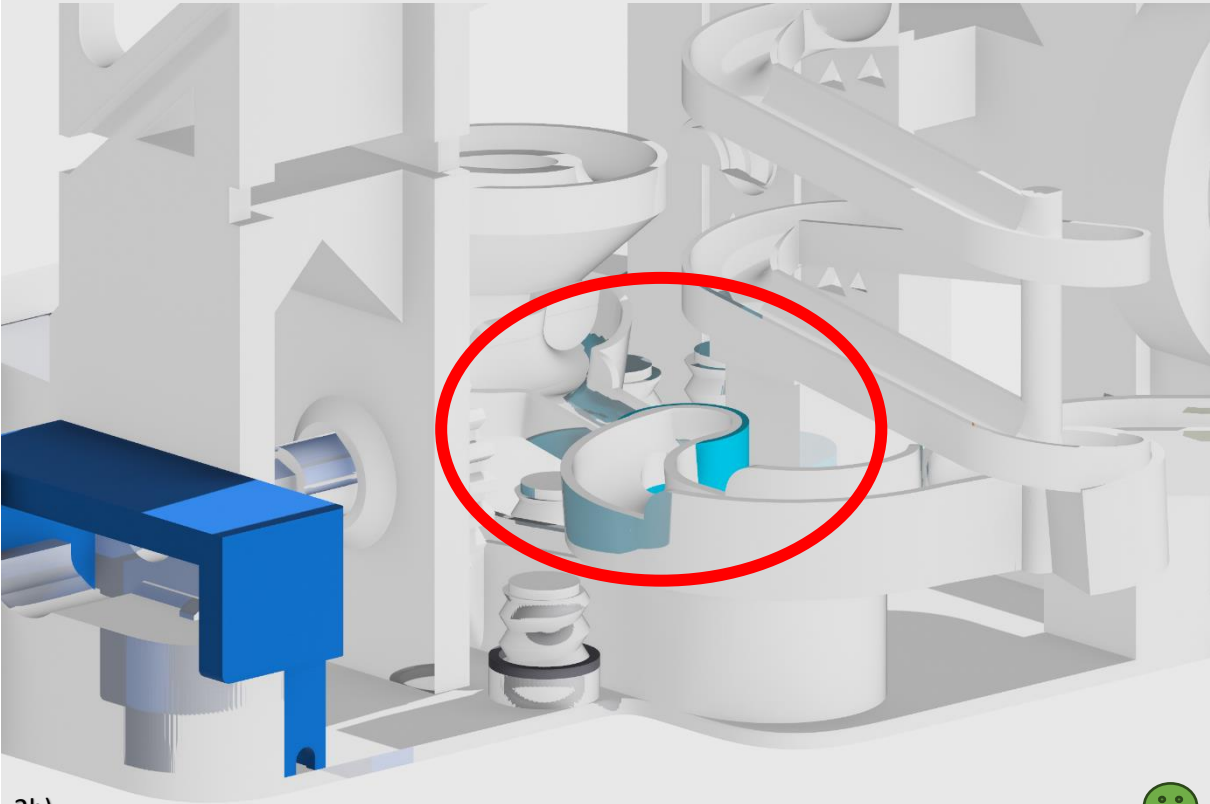

2b)



3. Attach Track Mount A (No.3) to the base plates and screw with the original screw nuts (pic 3c, 3d).

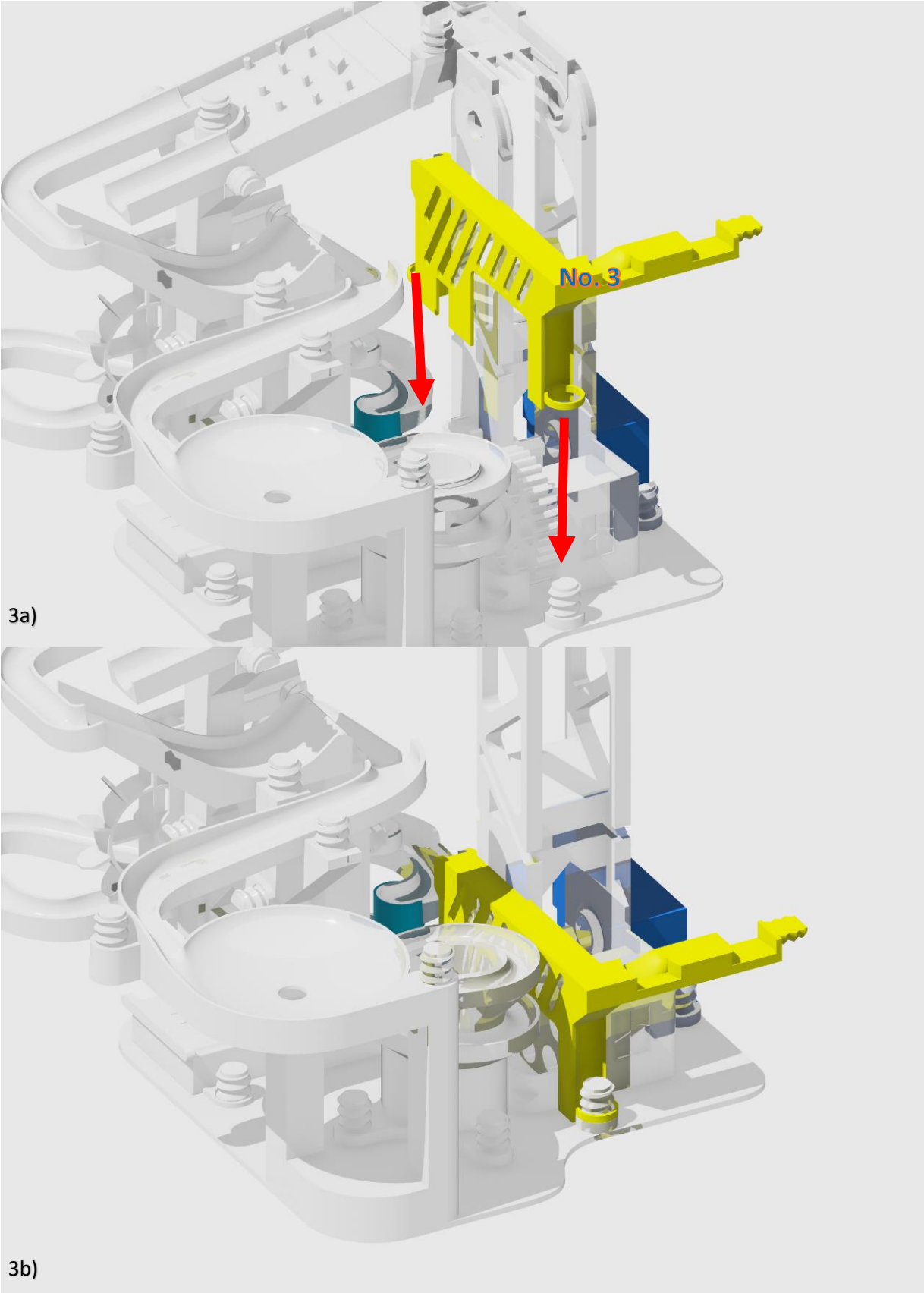

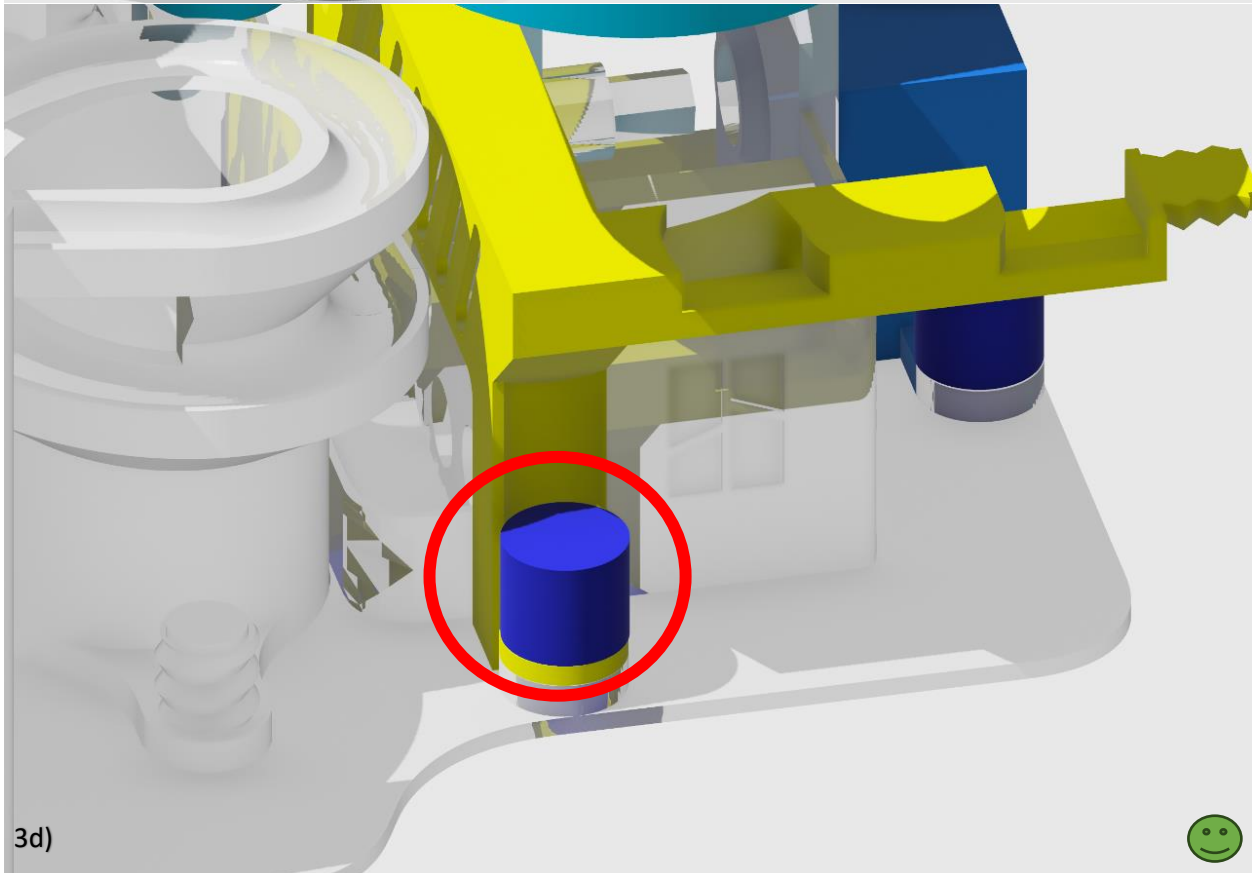
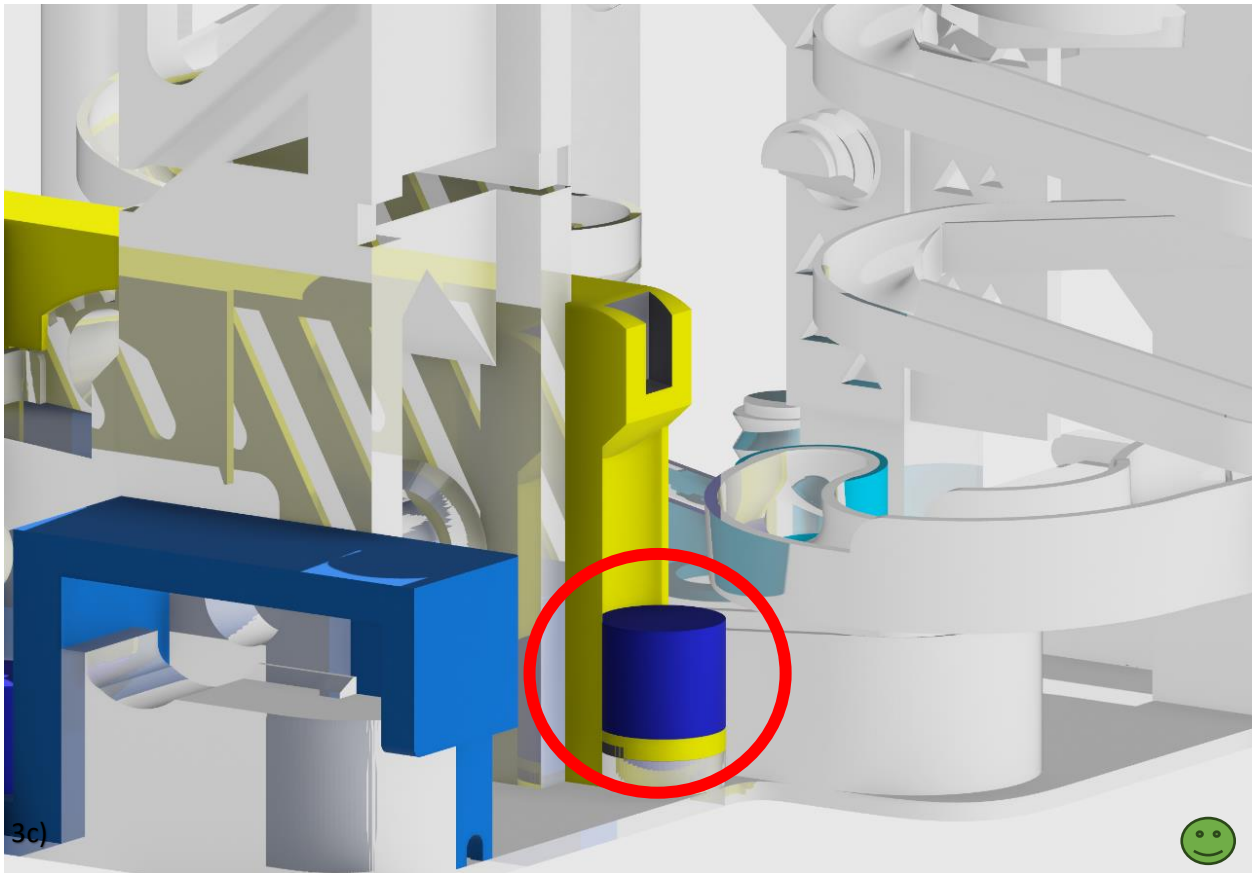

4. Attach Track Mount B (No.4) to Track Mount A (No.3).

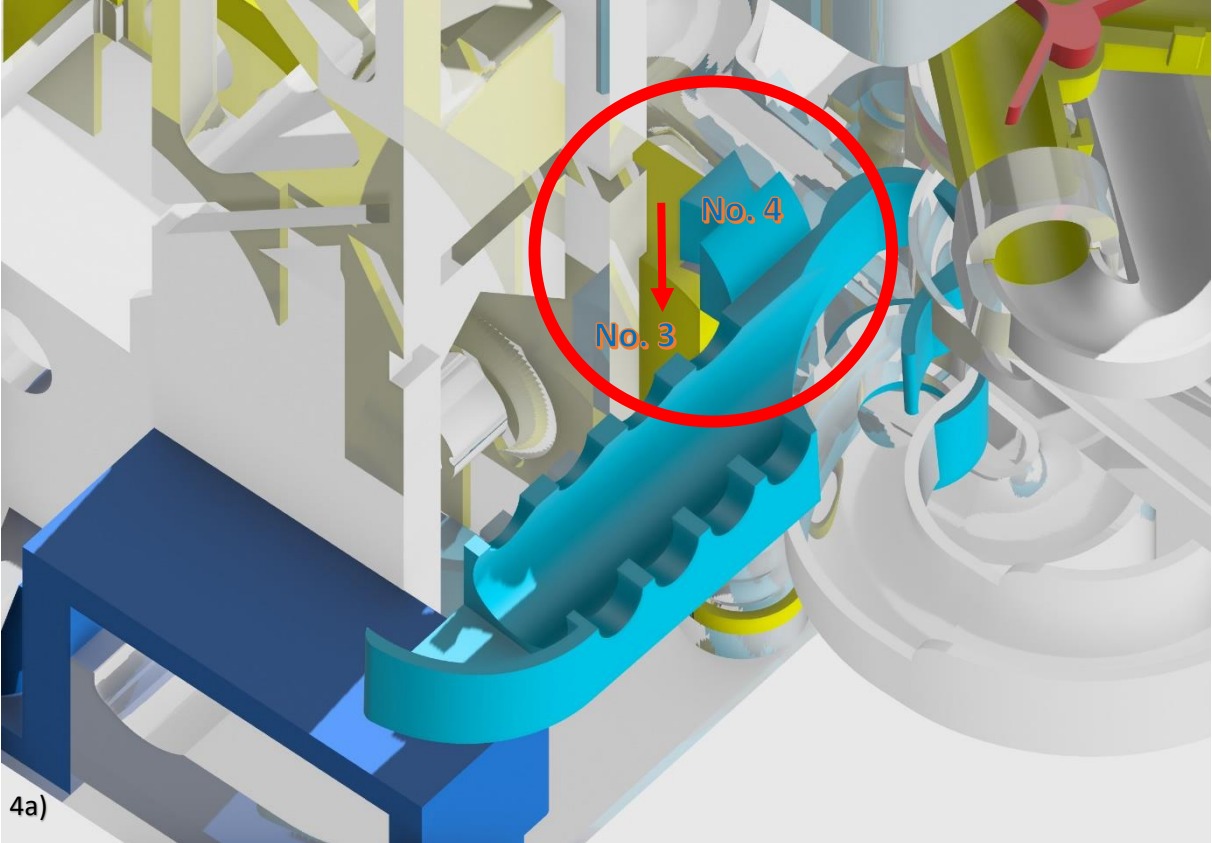

4a)

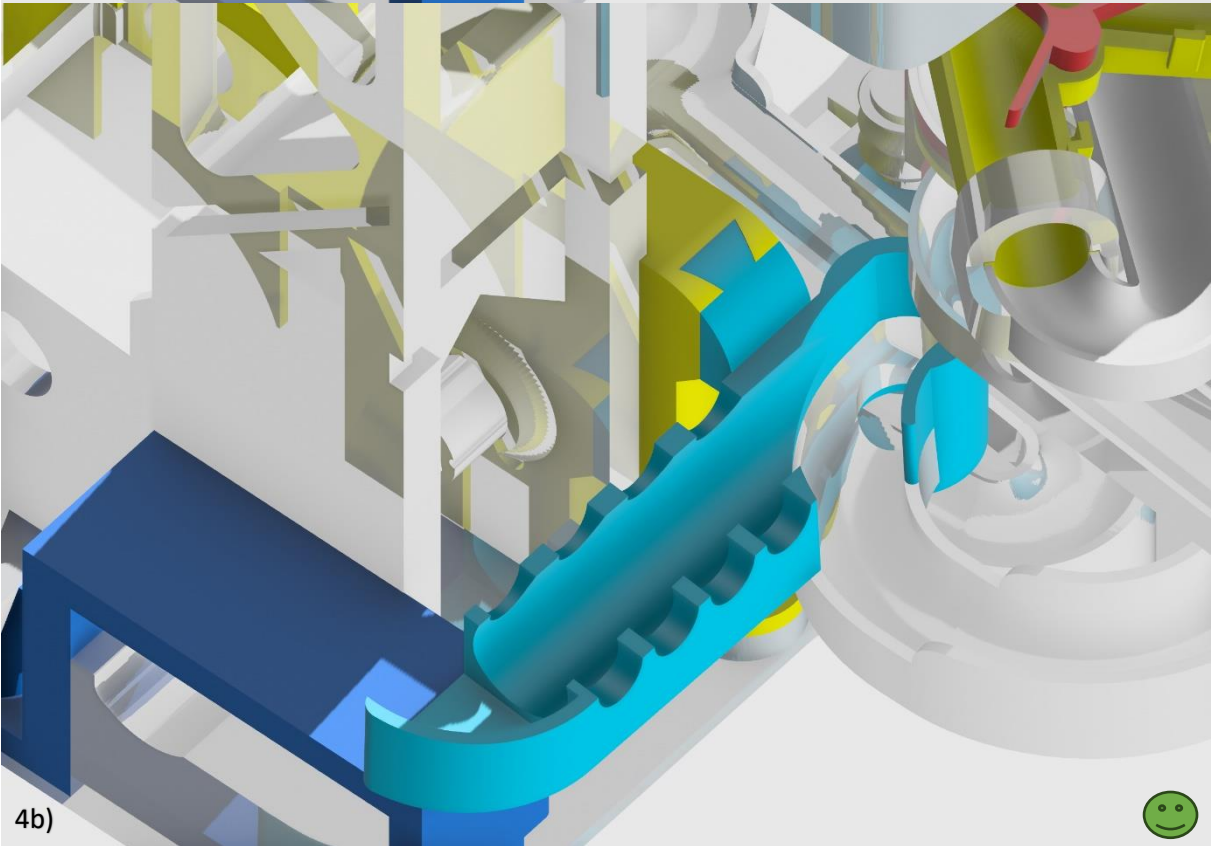

4b)

5. Replace the “Jump Catcher” and the “Fork / Fork Cross” from **Paddle Wheel v2 Plus Addon** by 4-Ways Jump Catcher / Slider (No.5/6) and 4-Ways Fork / Fork Cross (No. 10/11). Screw with the original screw nut.

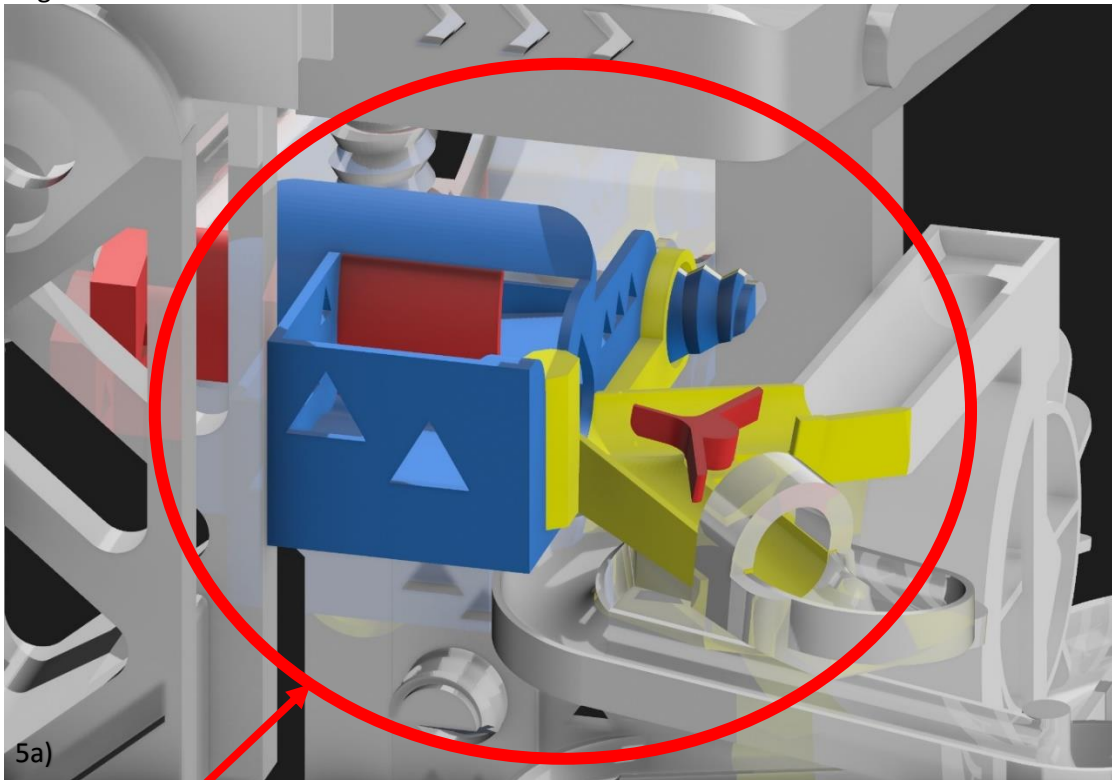

Remove

The slider can be used to get more control of what direction the marbles should take.

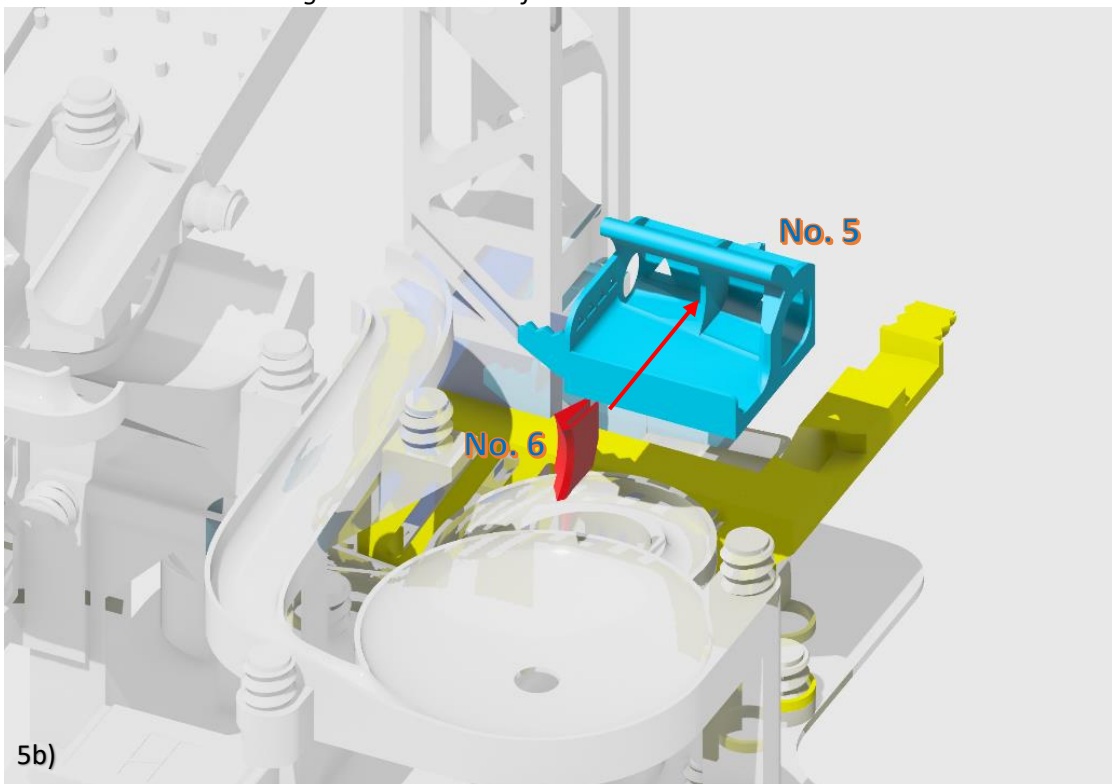

The Slider (No.6) can be used to get bit more control of which direction the marbles should take. However, ... it's always according to the random principle.

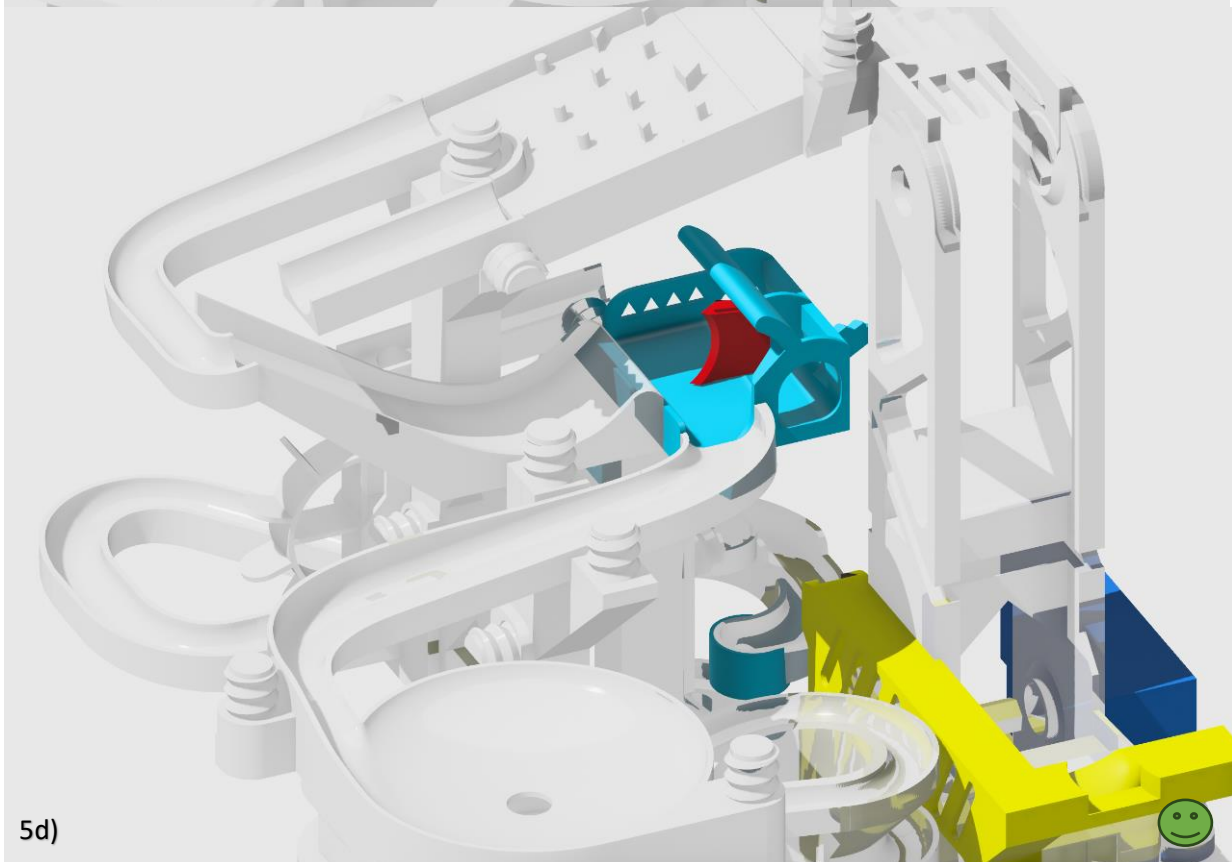
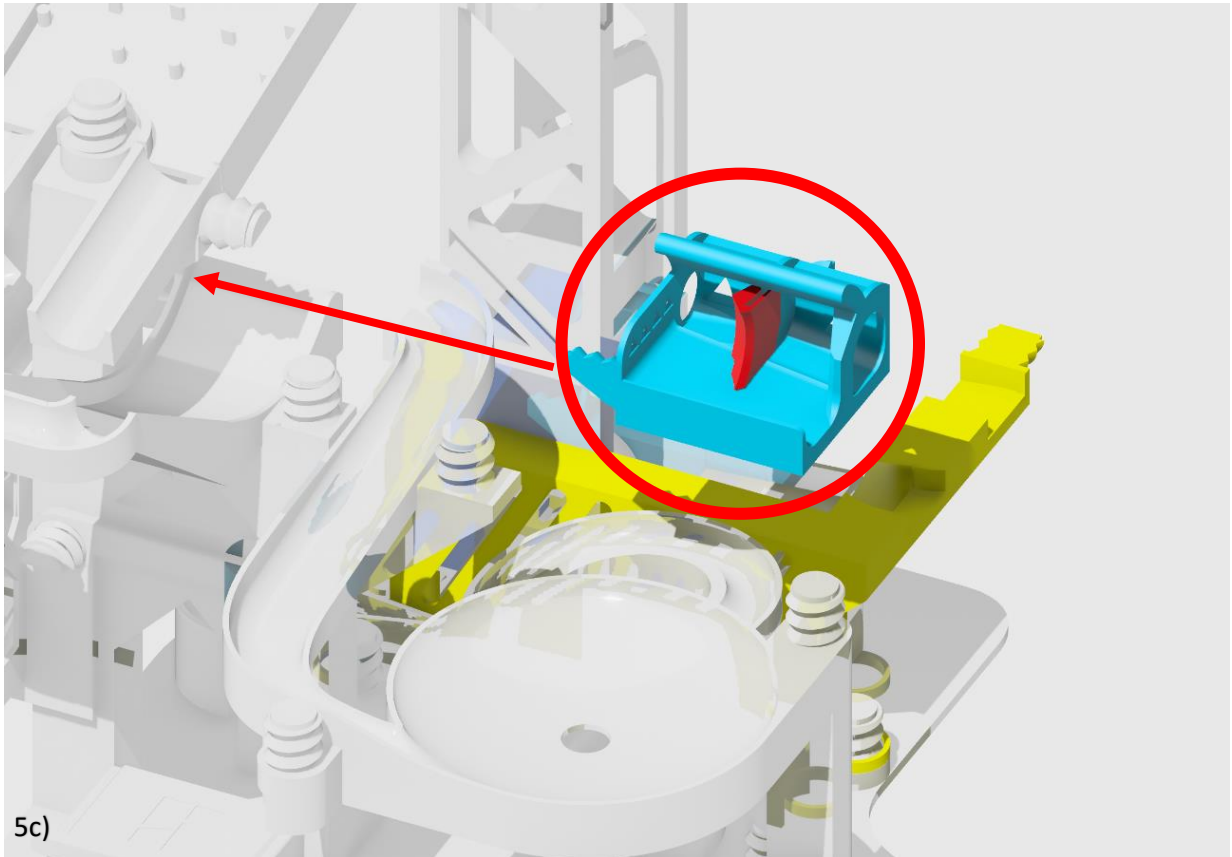

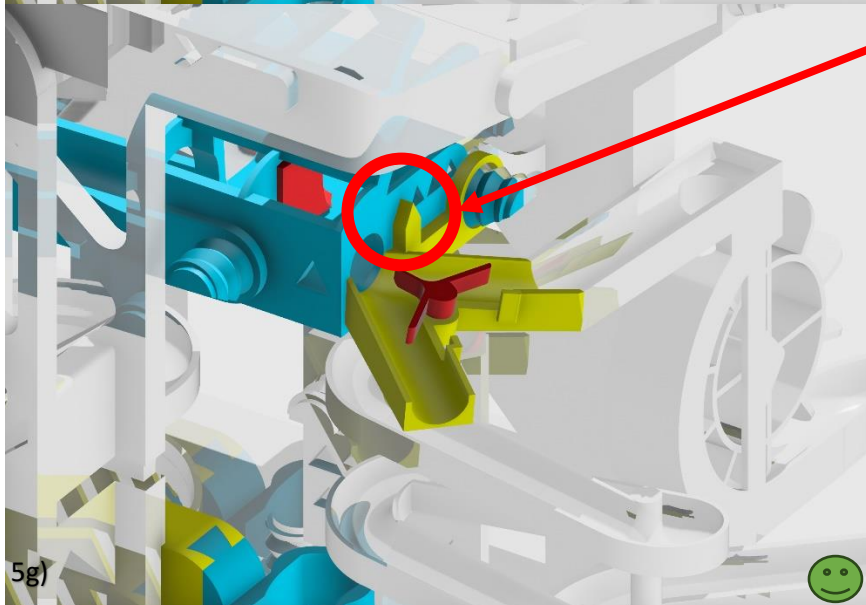
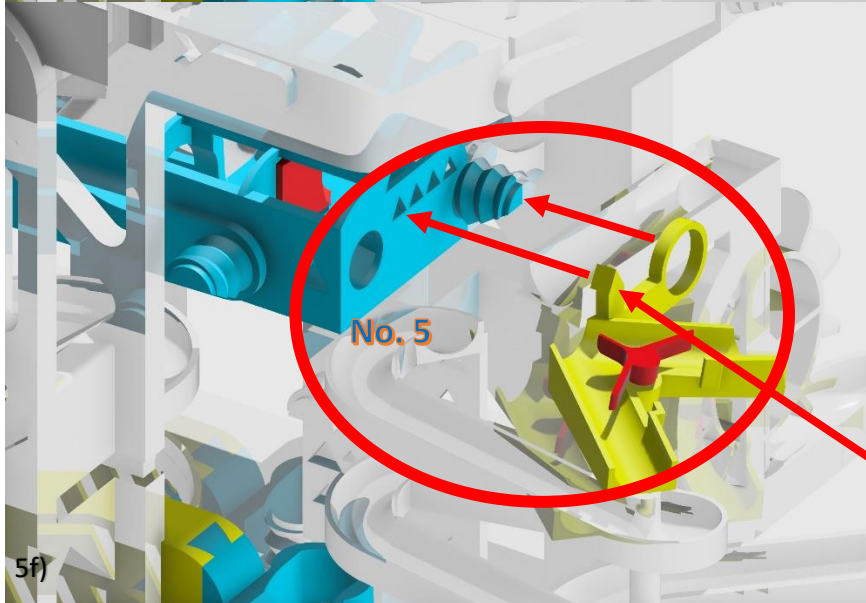
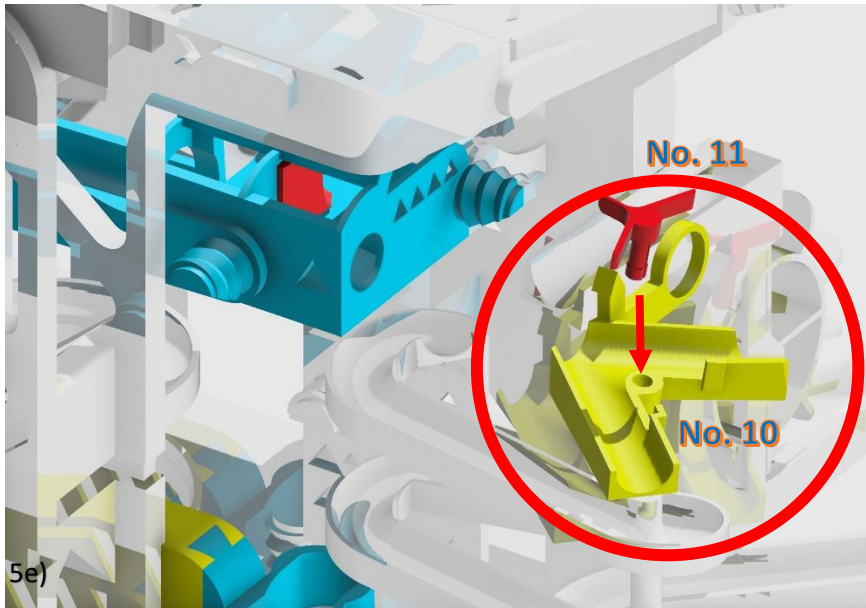

!!!

Align "triangle" with "triangle window".

6. Connect the Serpentine (No.9) to Track Mount A (No.3) and B (No.4)

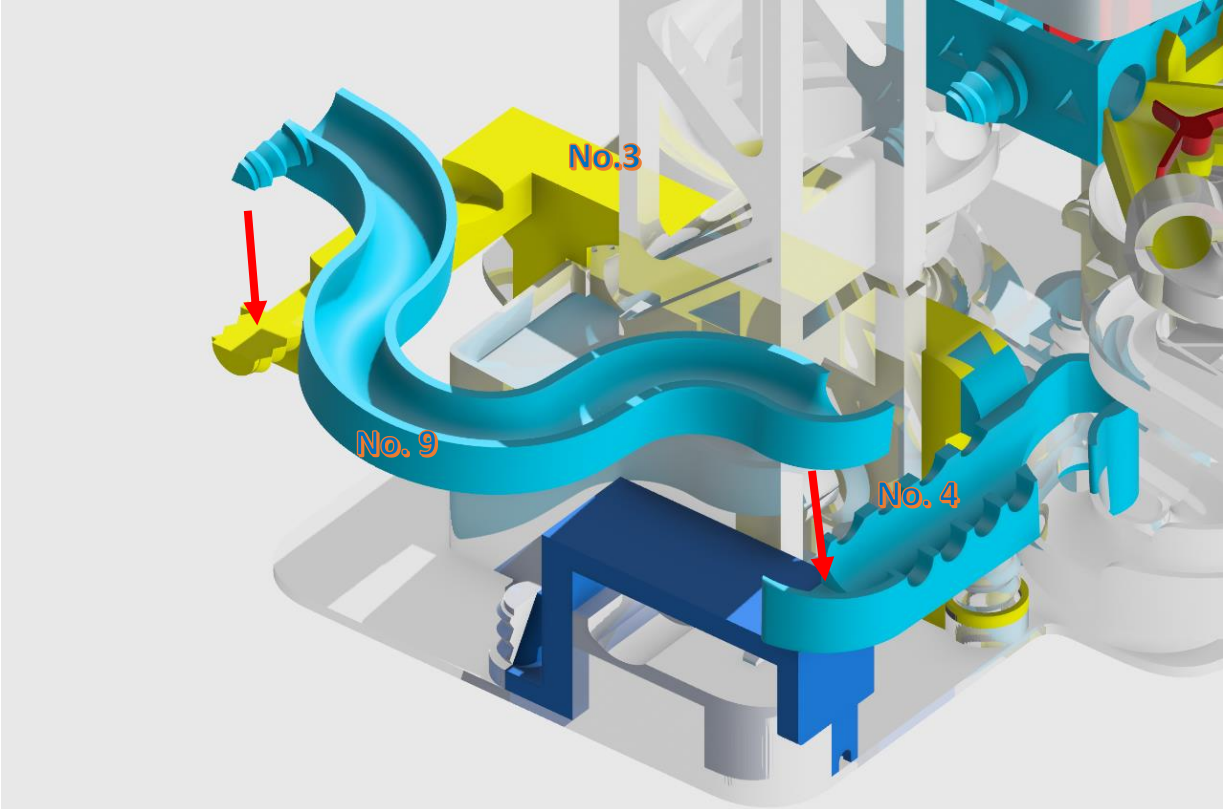

6a)

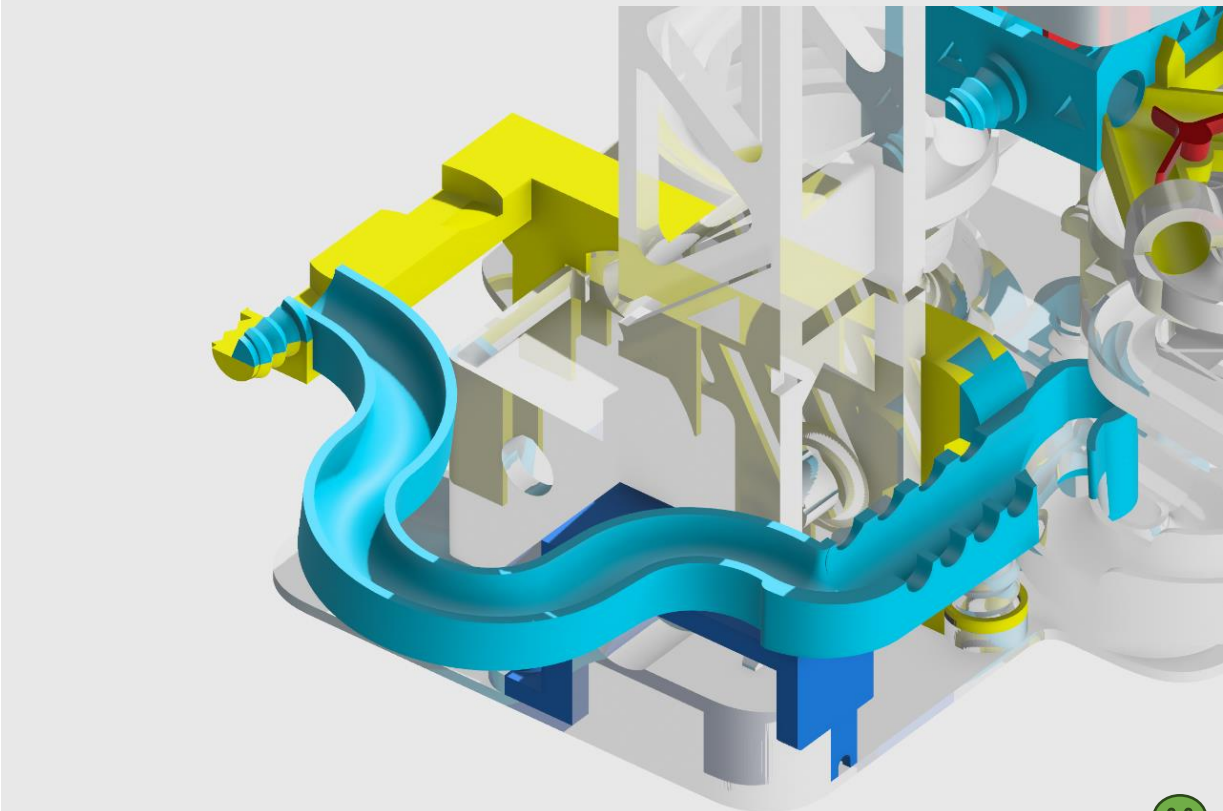

6b)



7. Connect the Helix (No.8) to the Track Mount A (No.3) and screw it with screw nut (No.12)

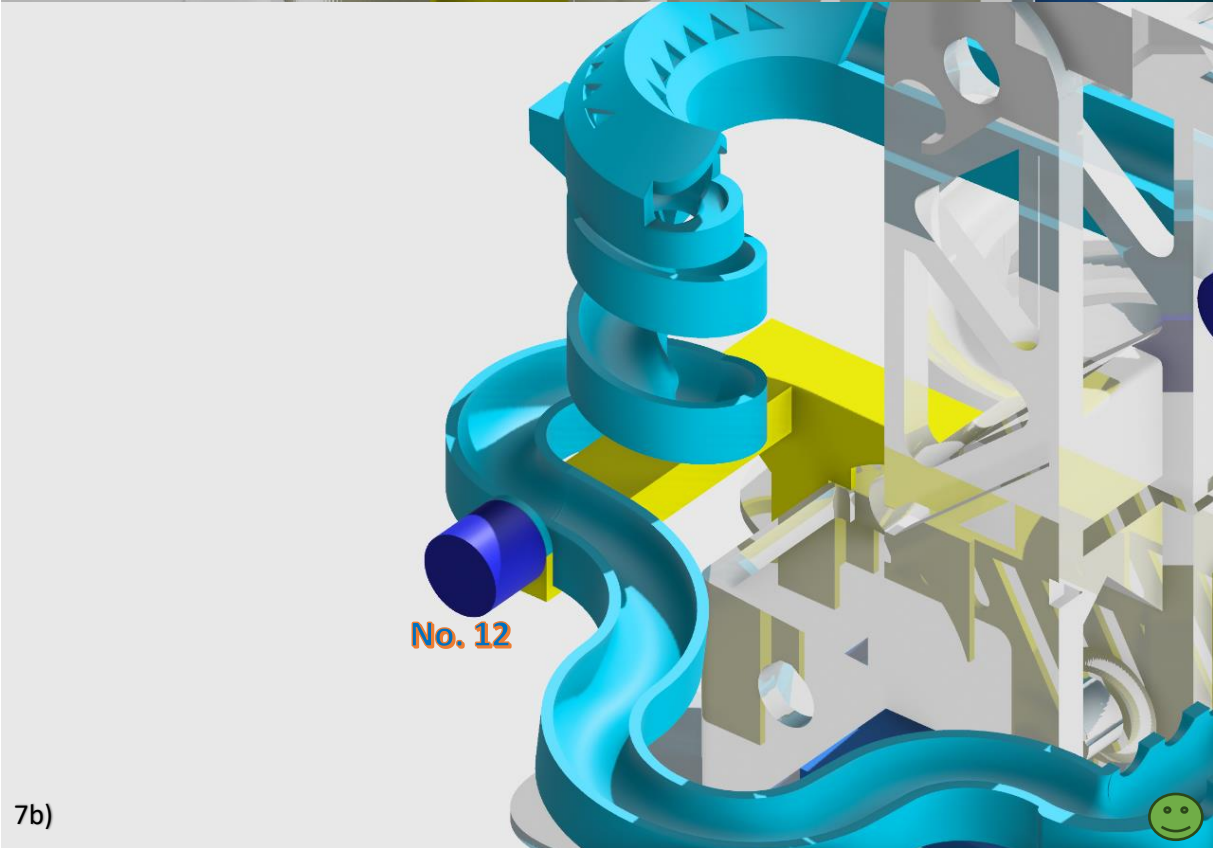
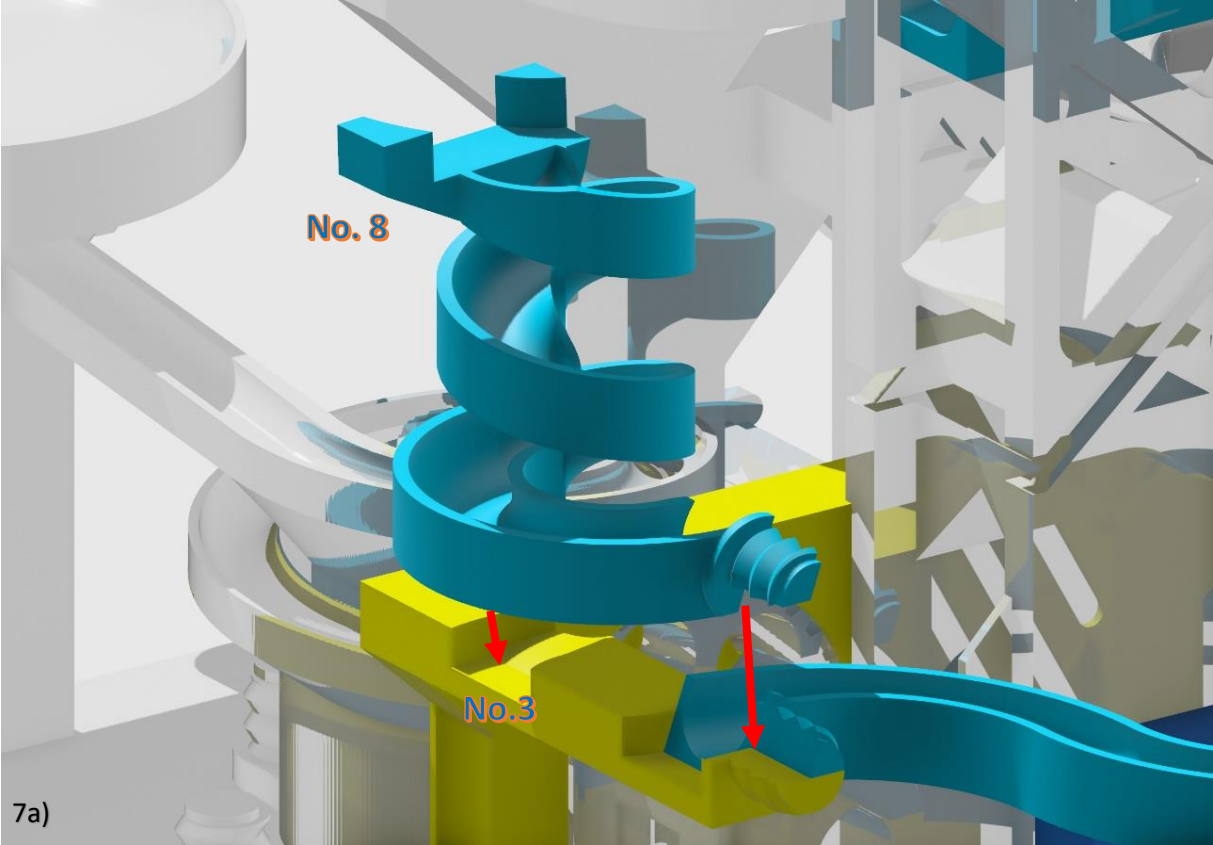

8. Connect the J-pipe (No.7) to the Helix (No.8) and 4-Ways Jump Catcher (No.5) and screw it with the screw nut (No.13)

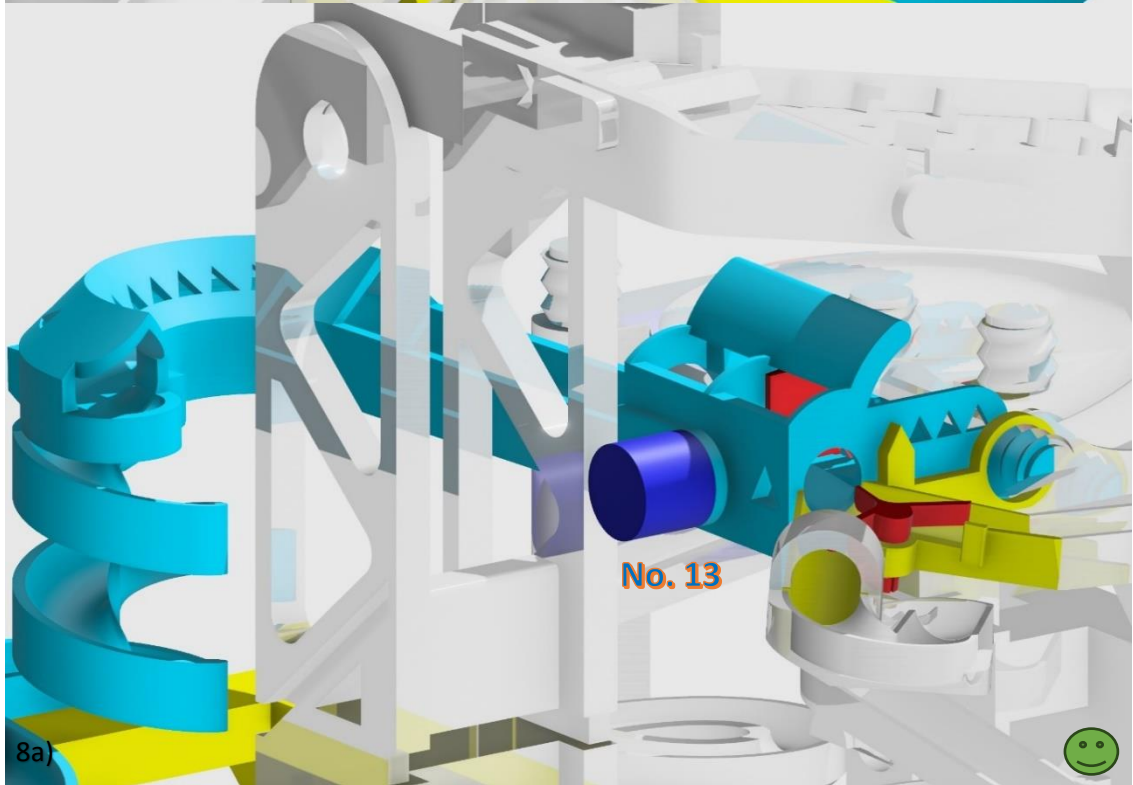
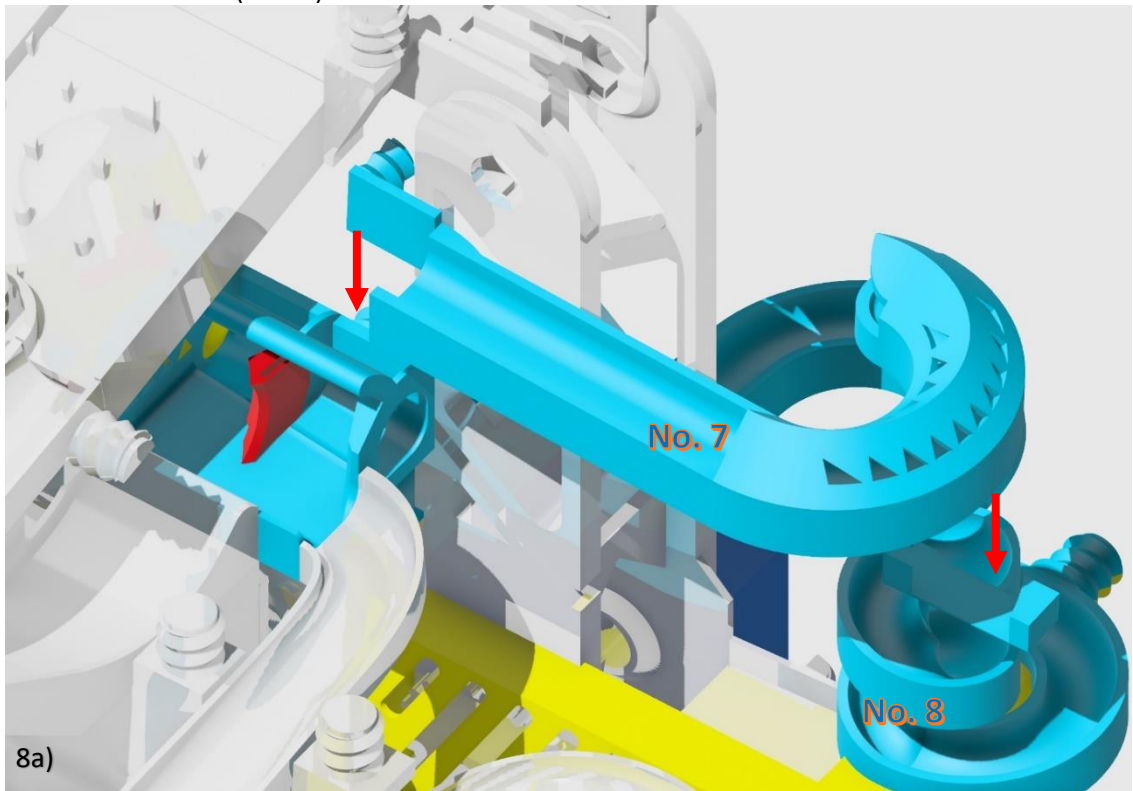

ENJOY !!!

