



Batwing

1989

3D printing model

Assembly manual
for **DLP/SLA**

Gamebody

1

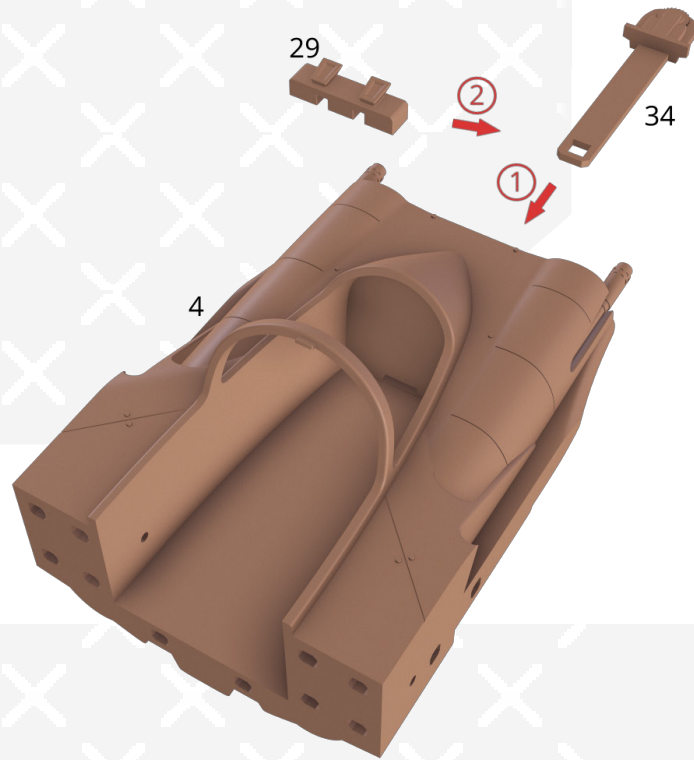

2

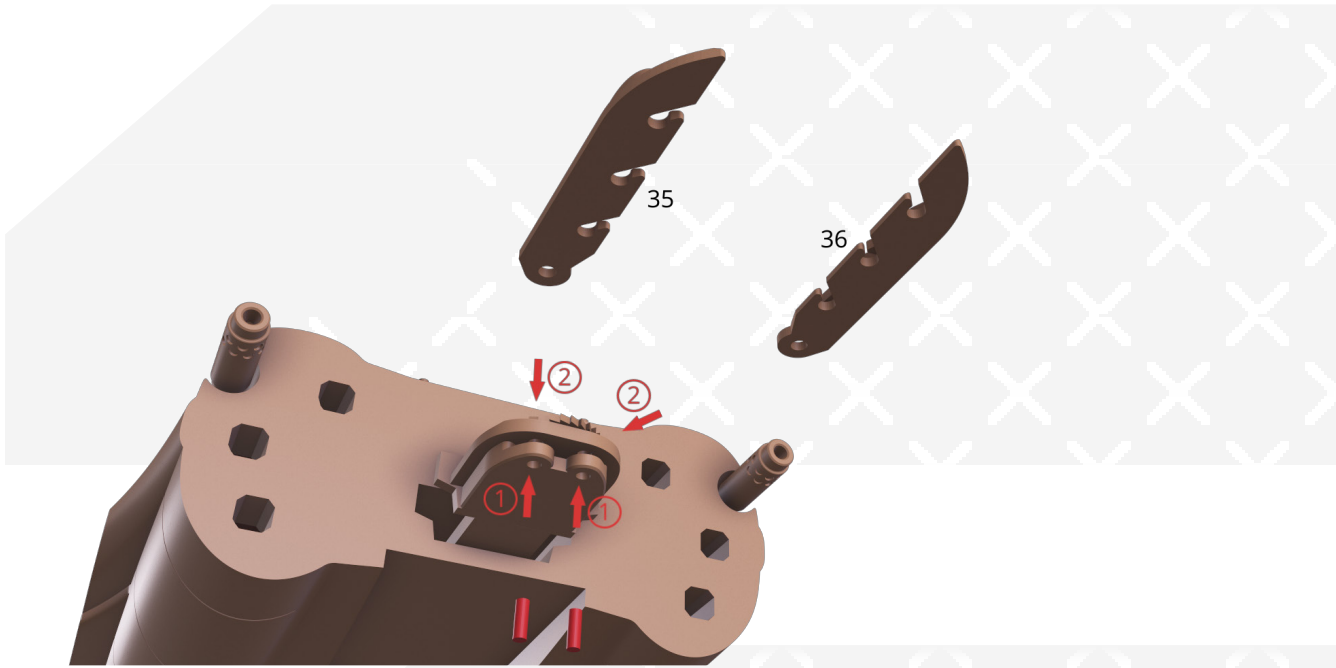

The assembly of the SLA version requires pins made out of short pieces of regular paper clips.

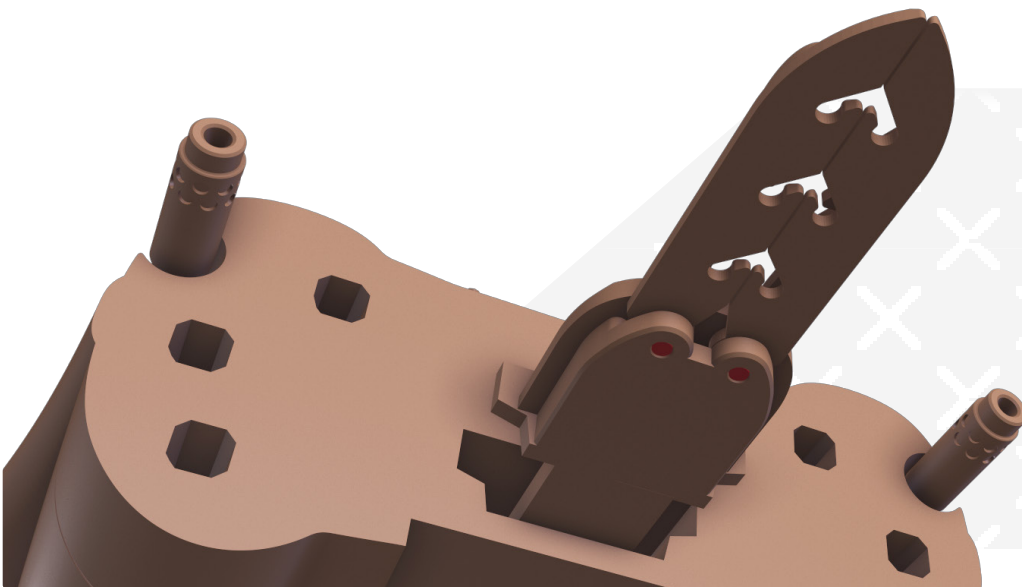

3

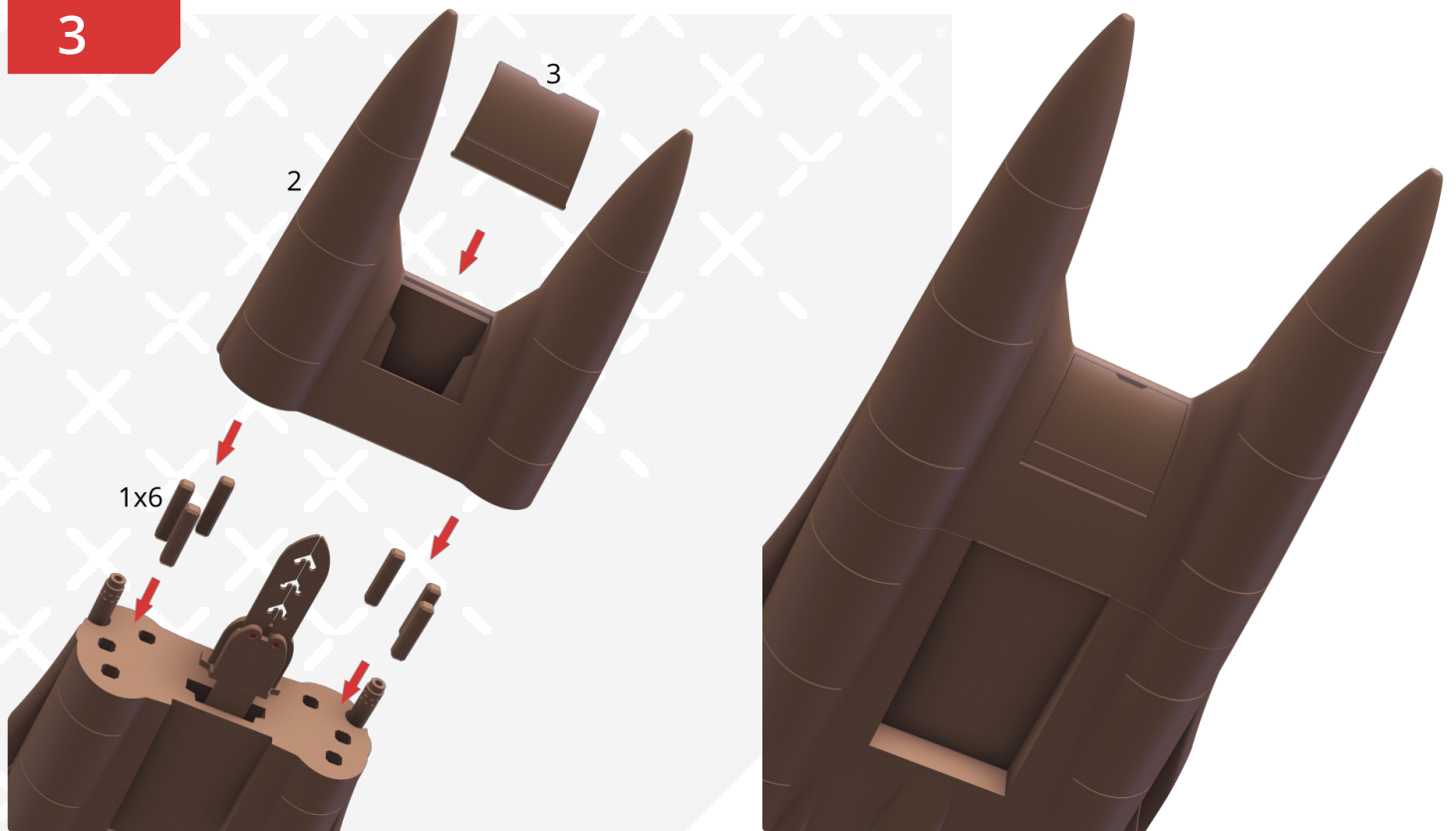

4

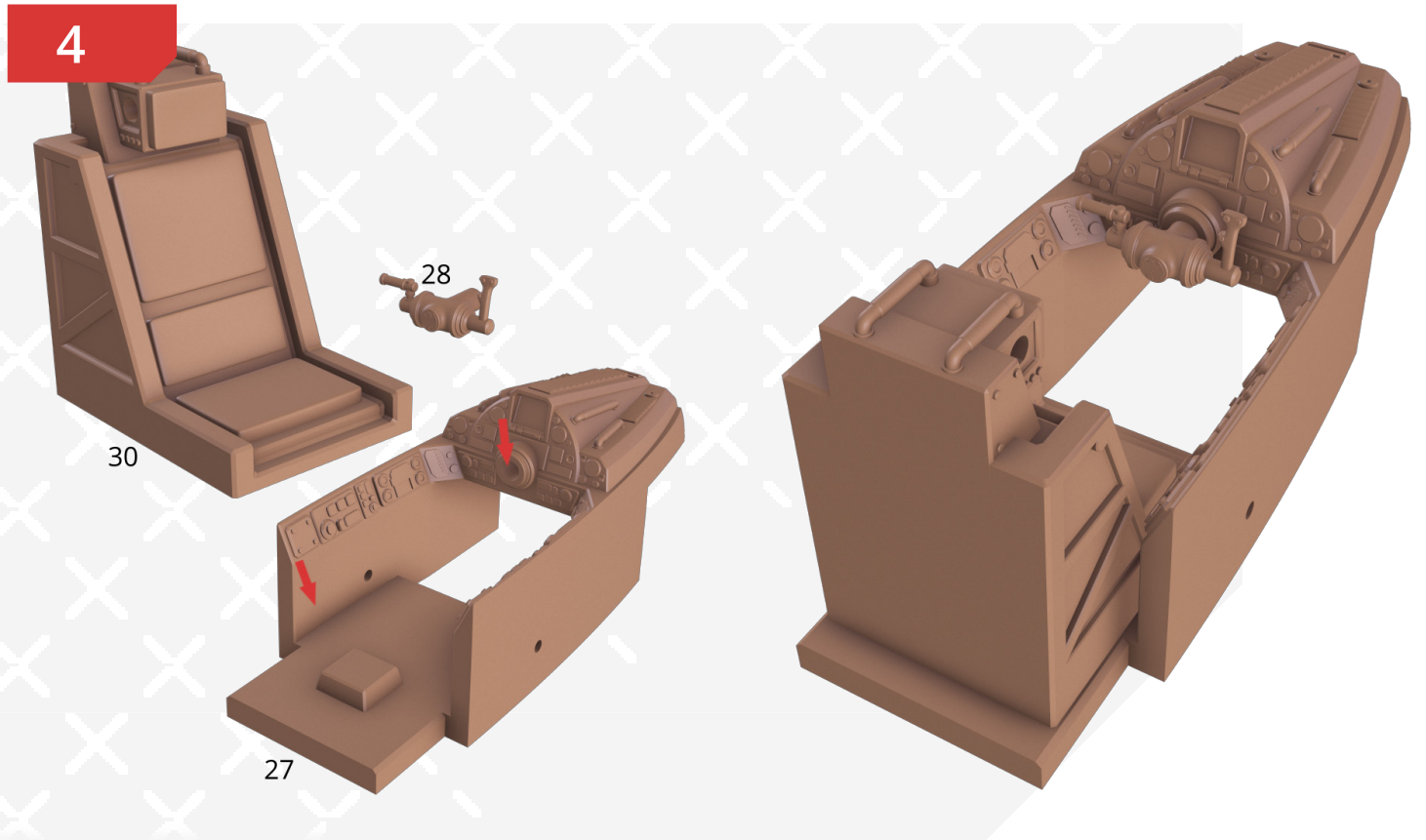

5

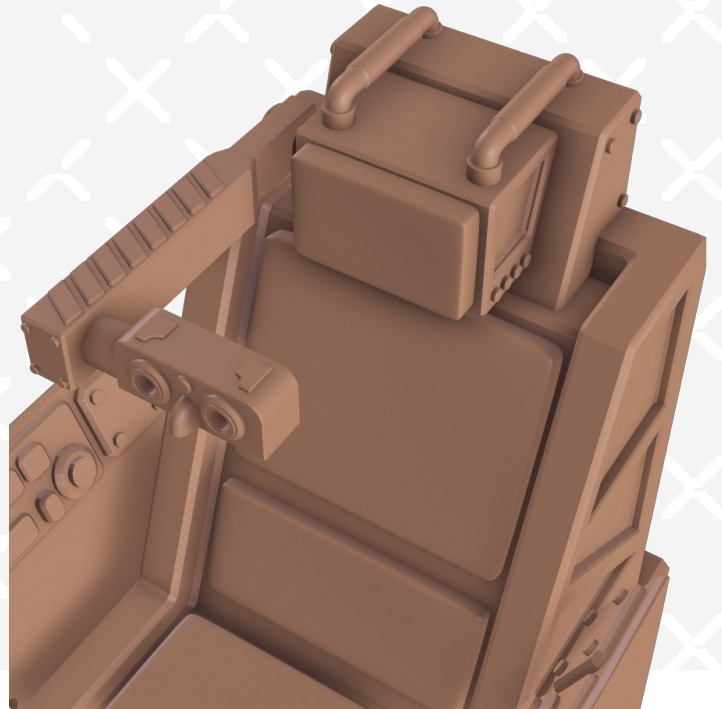
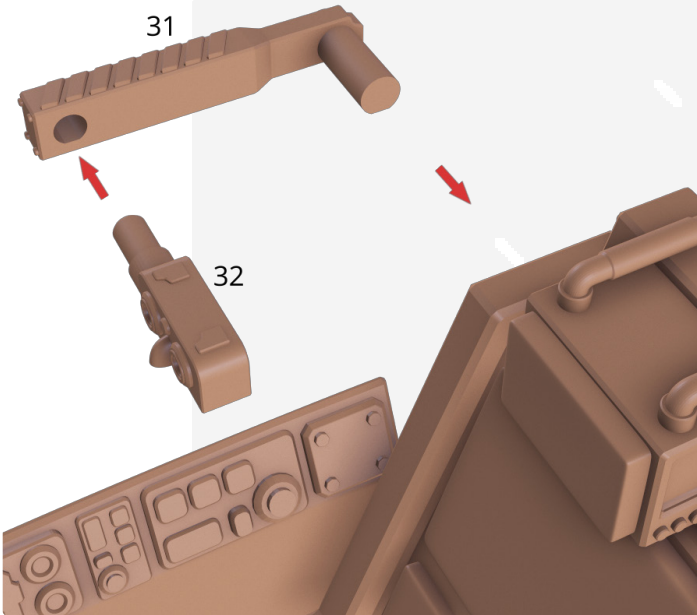

6

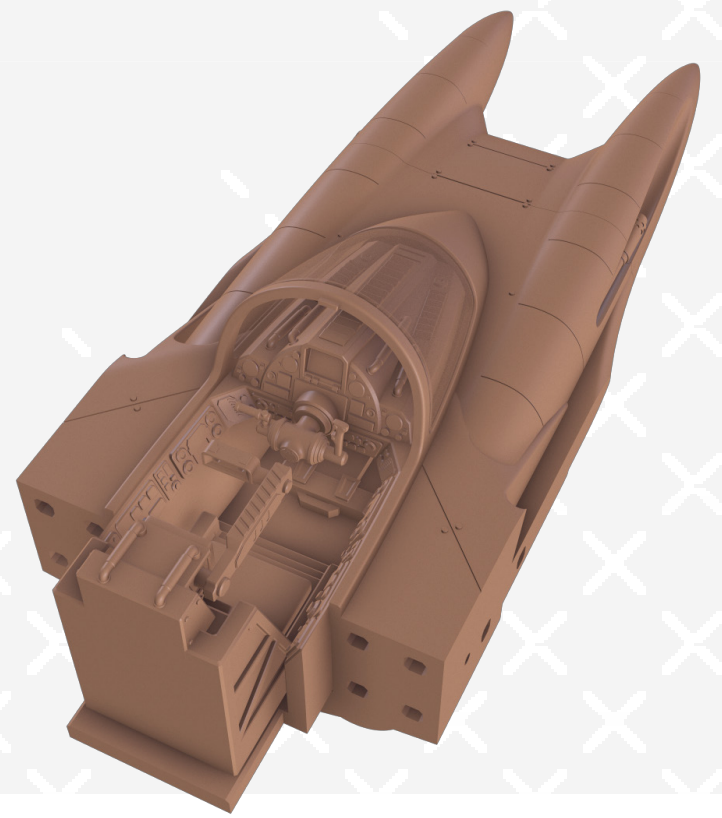
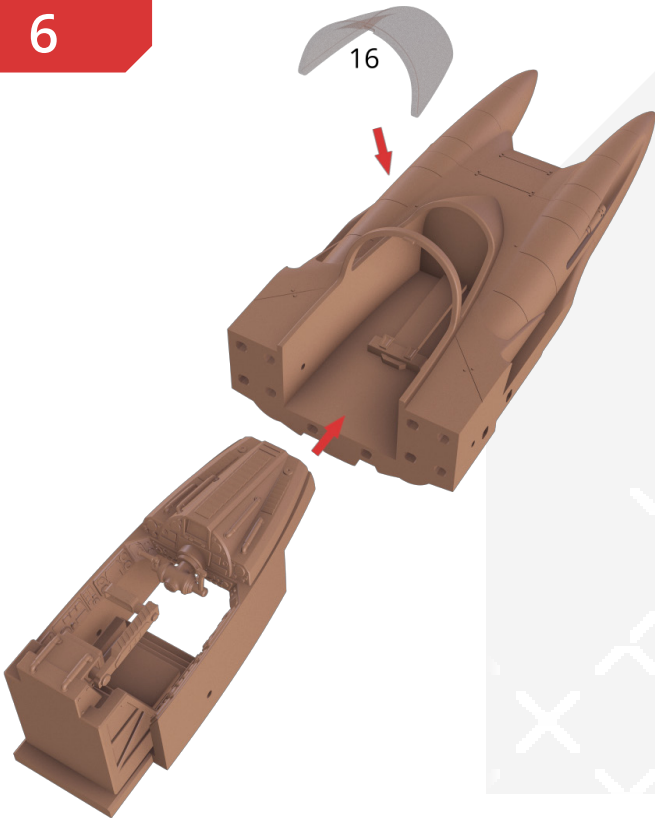

7

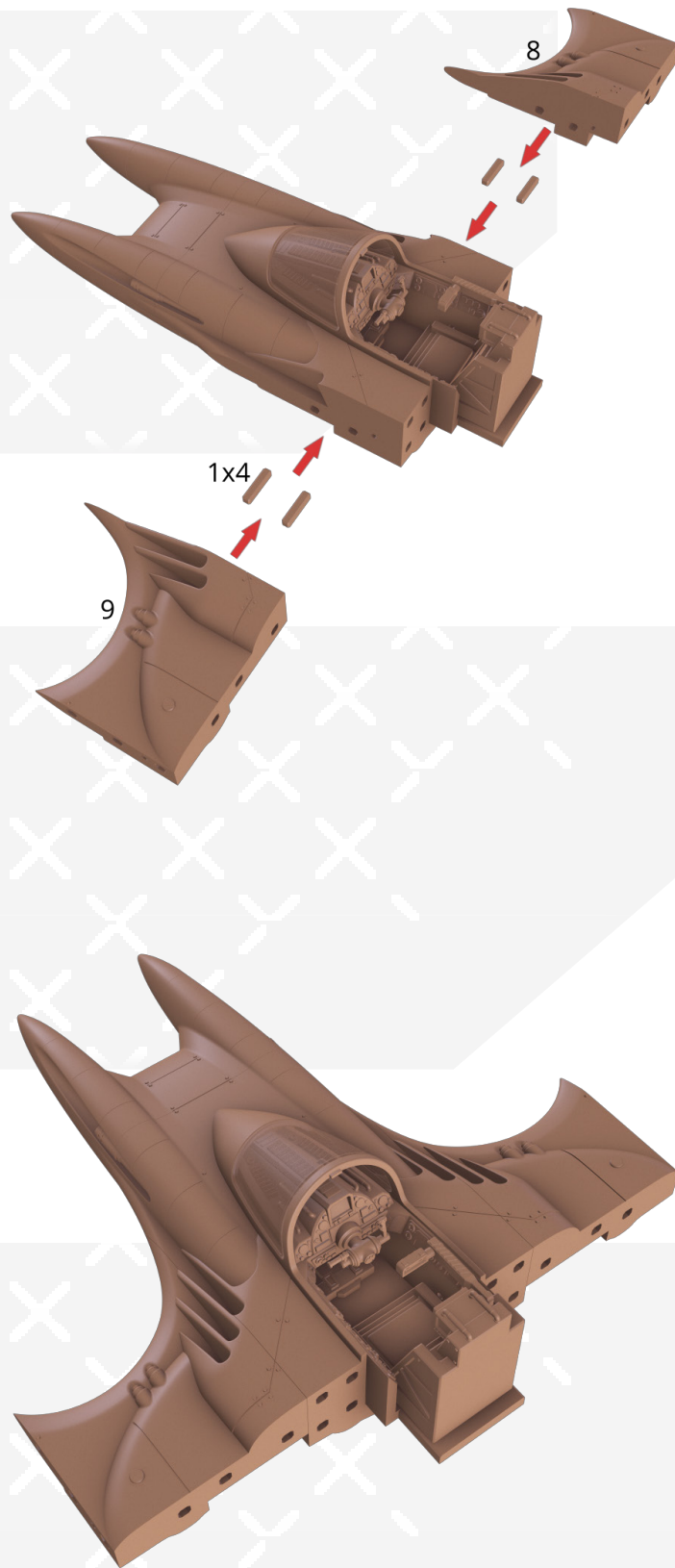

8

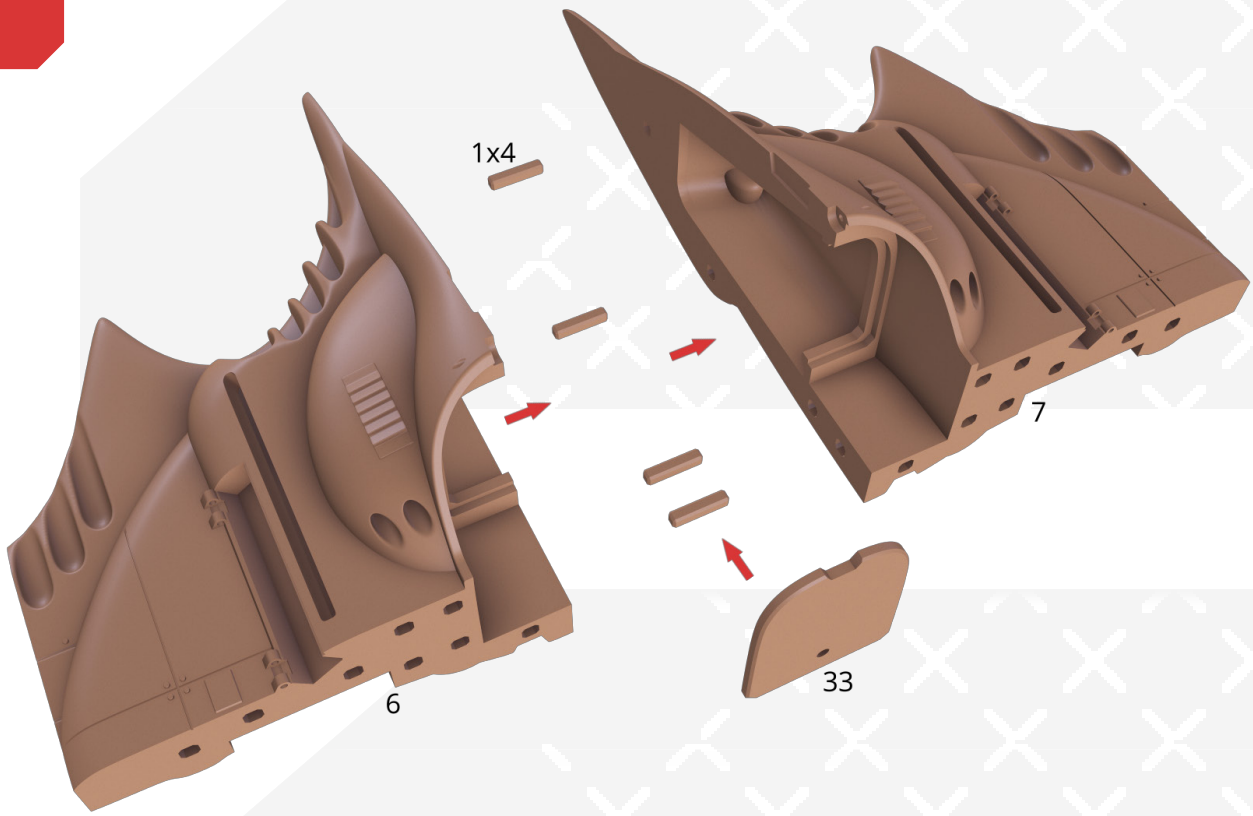

9

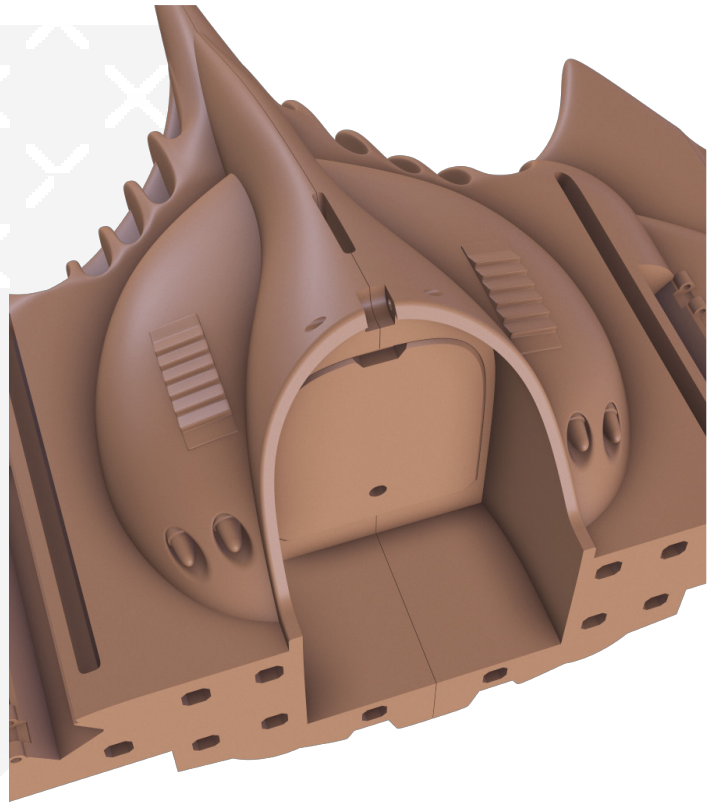
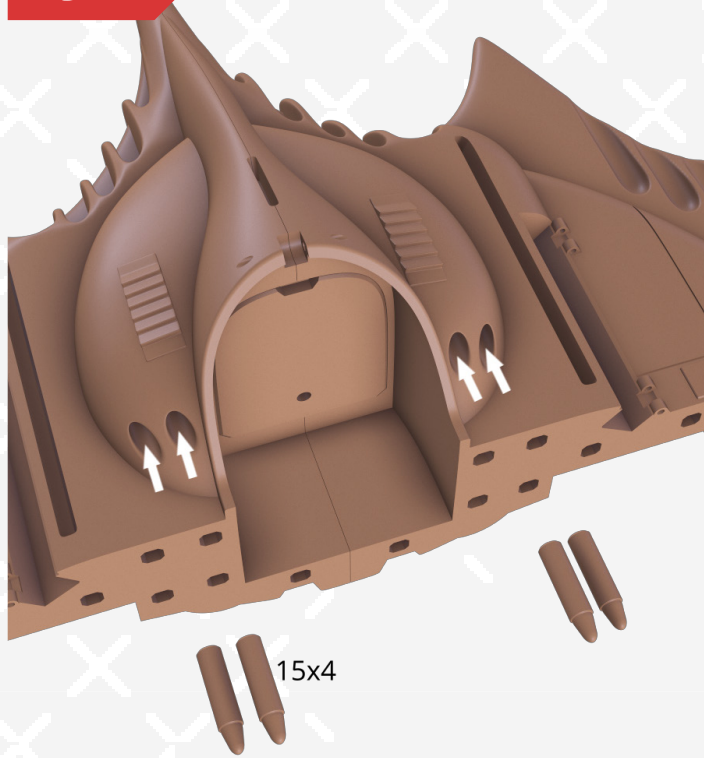

10

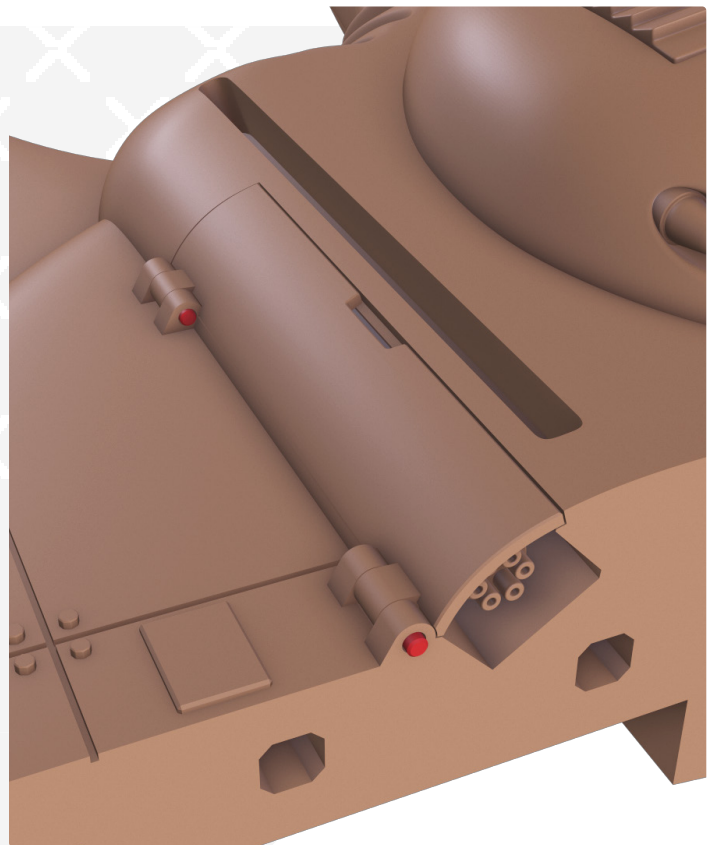
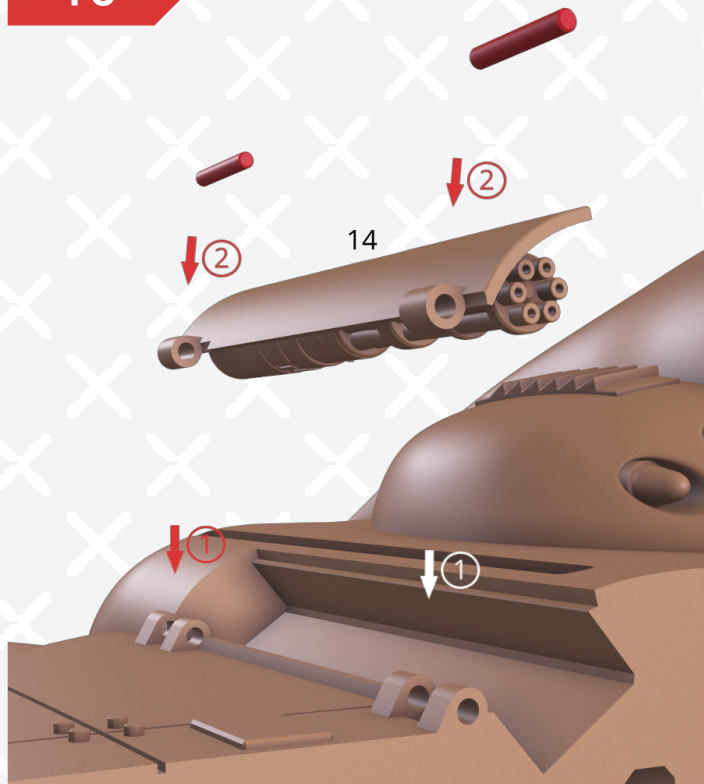

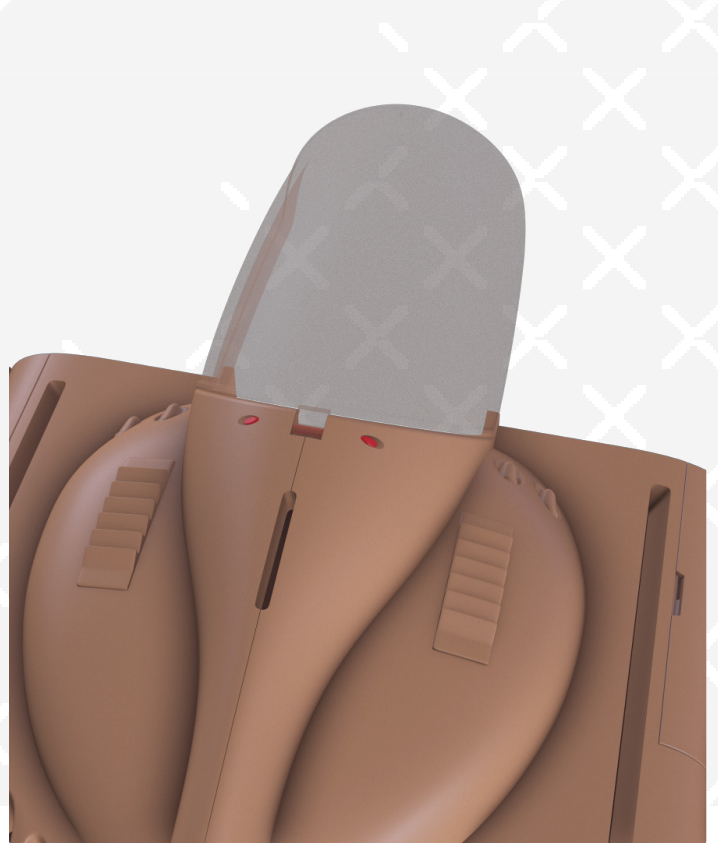
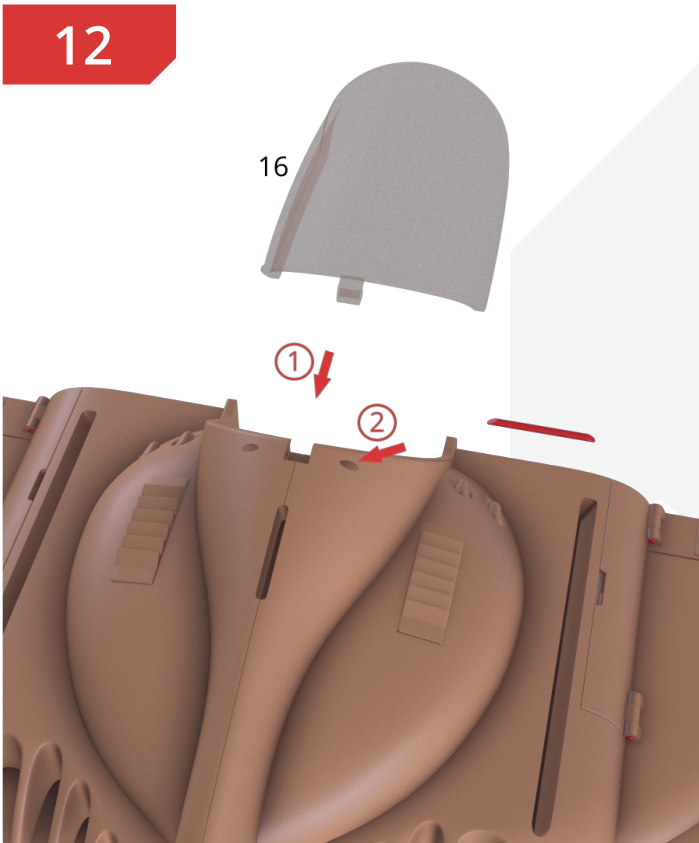
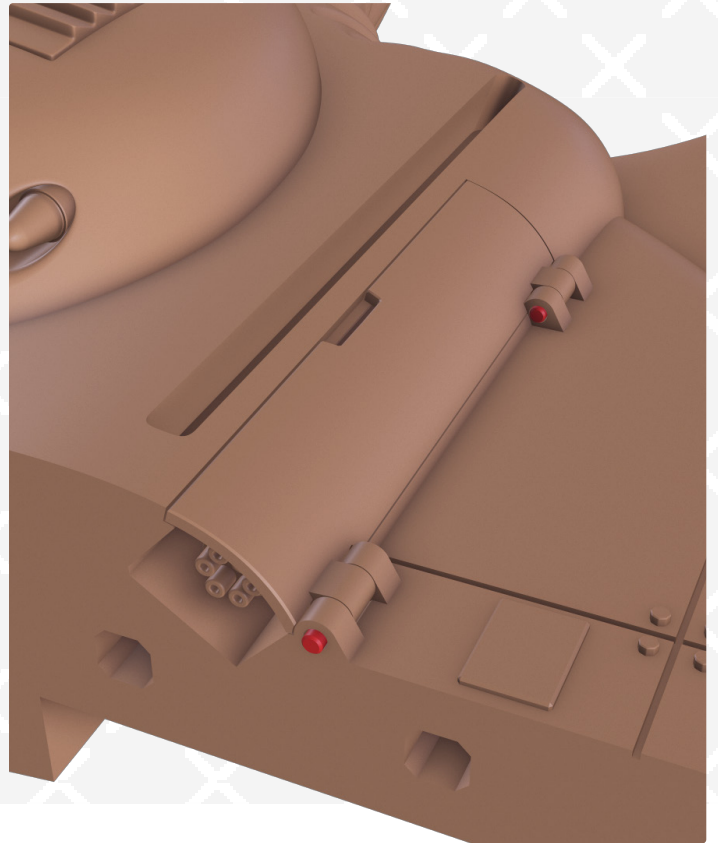
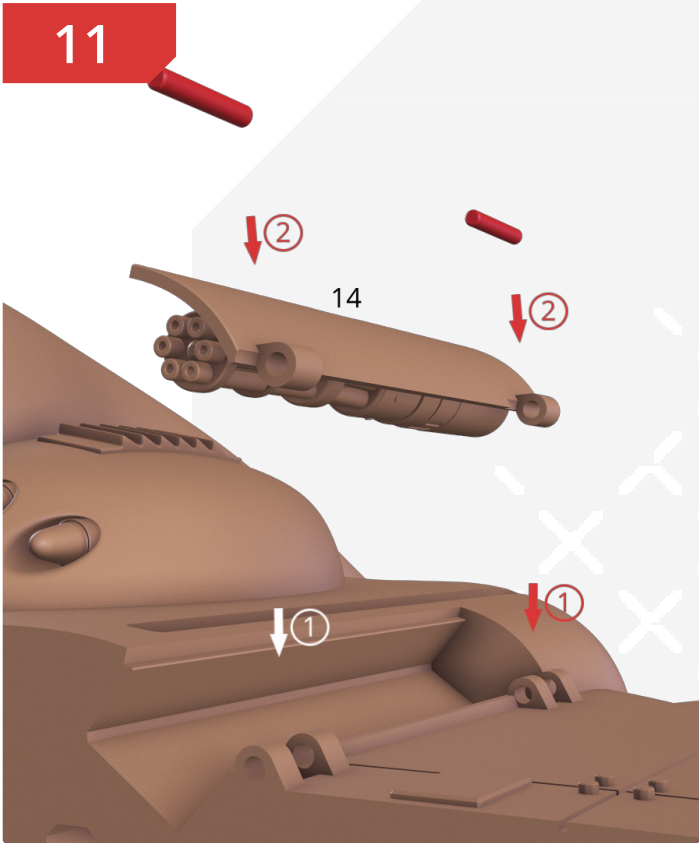

13



14

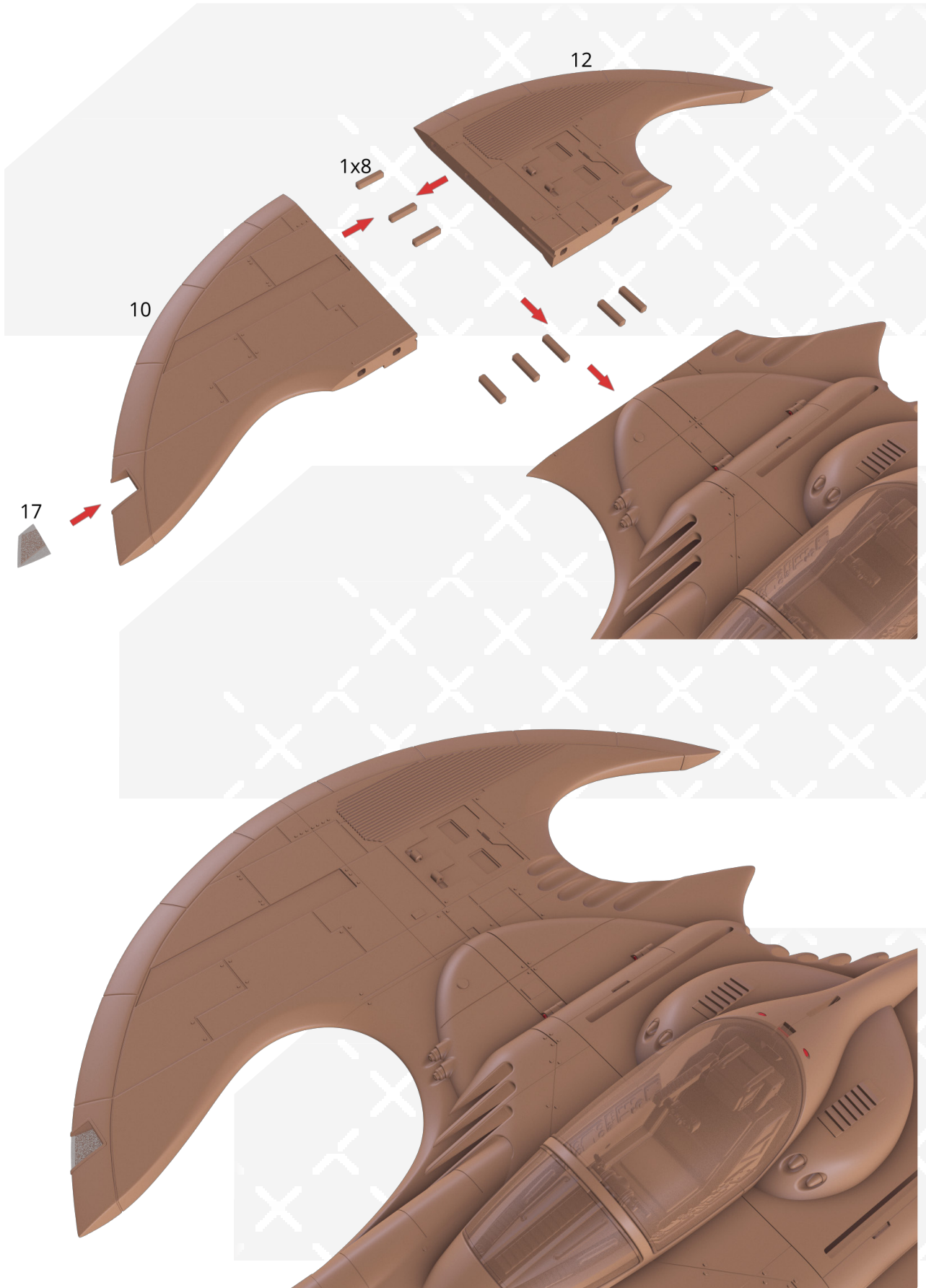

15

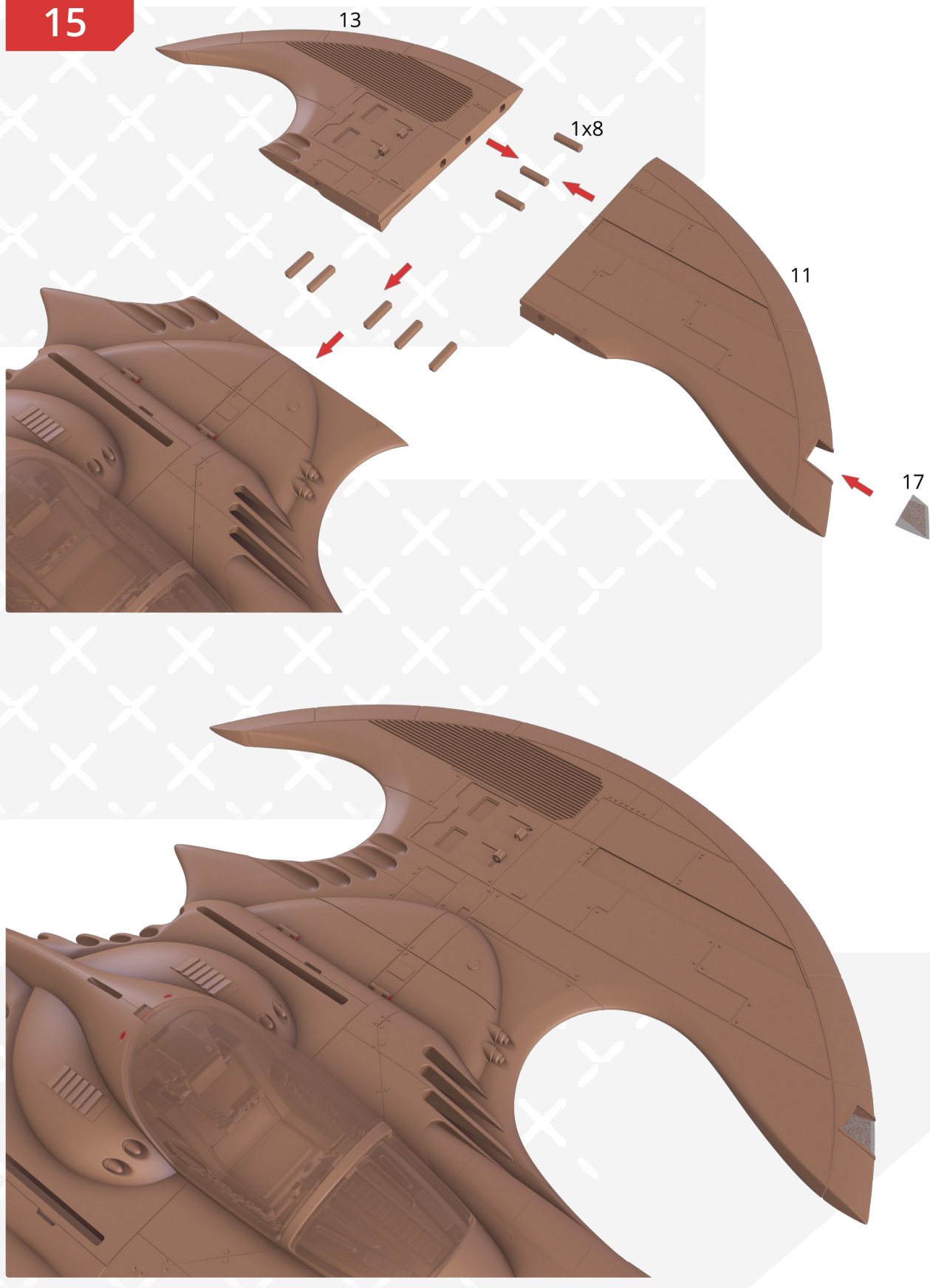

16

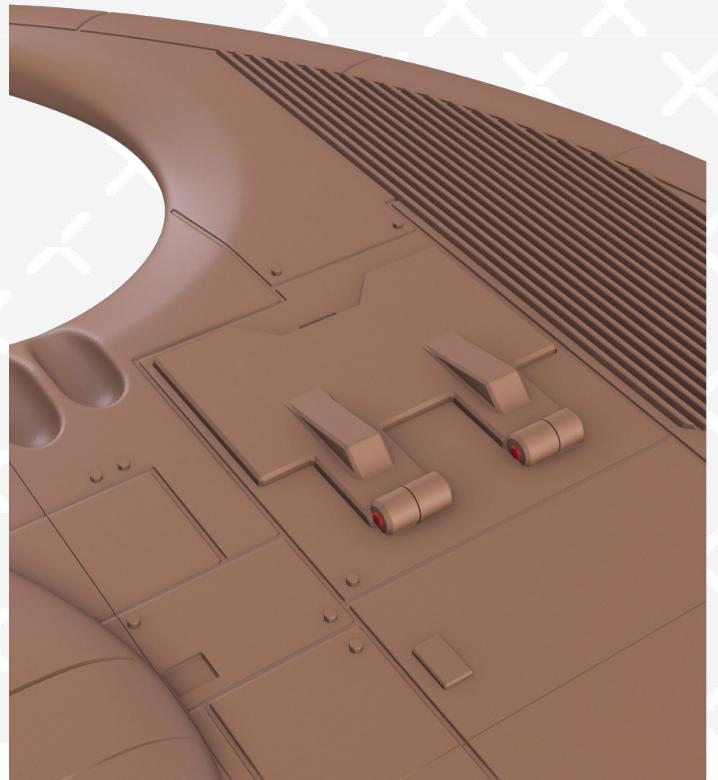
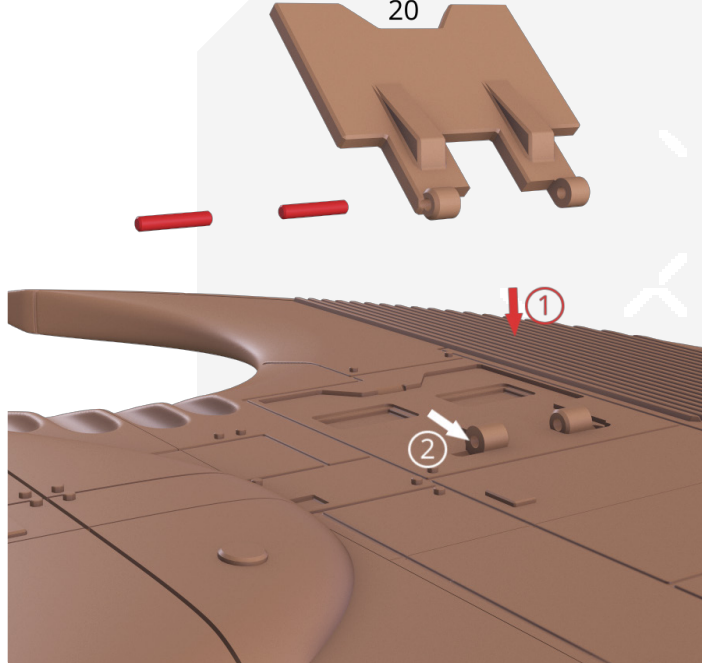

17

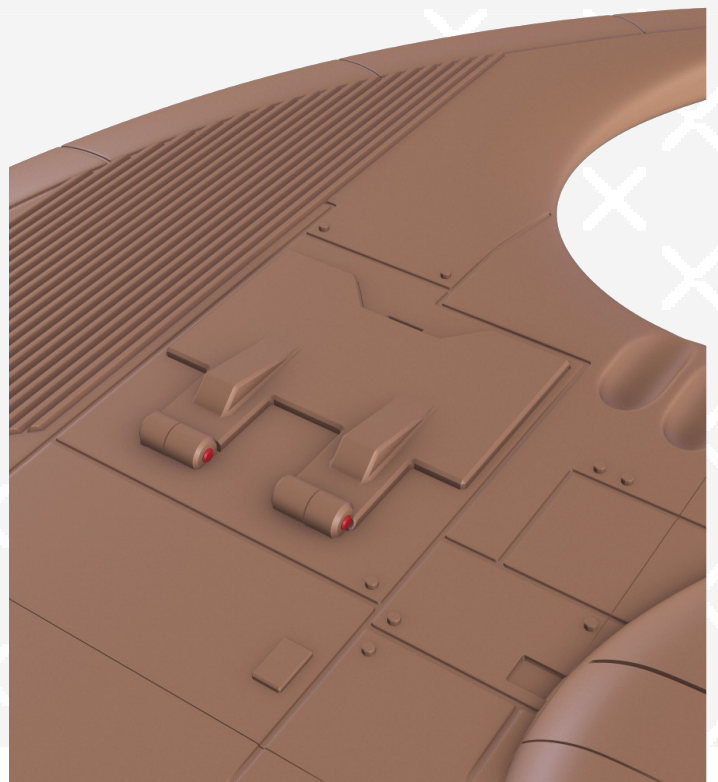
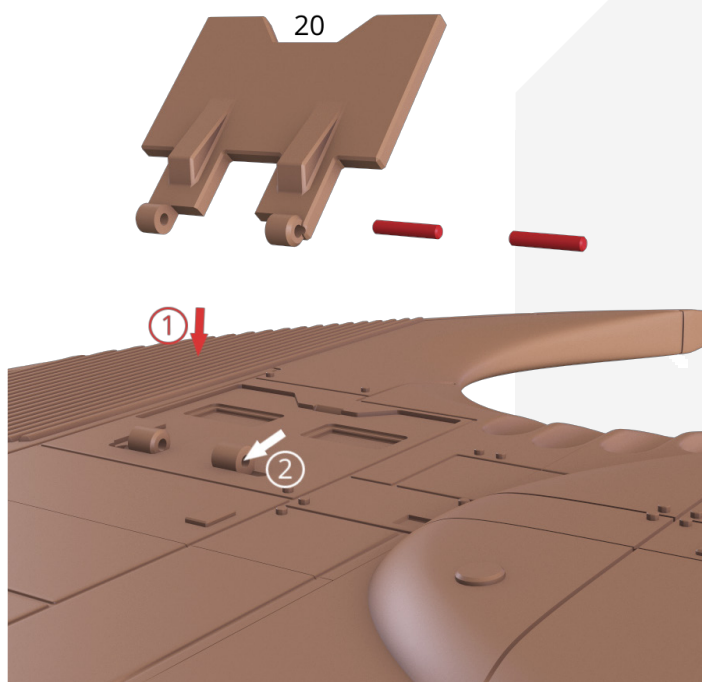

18



19

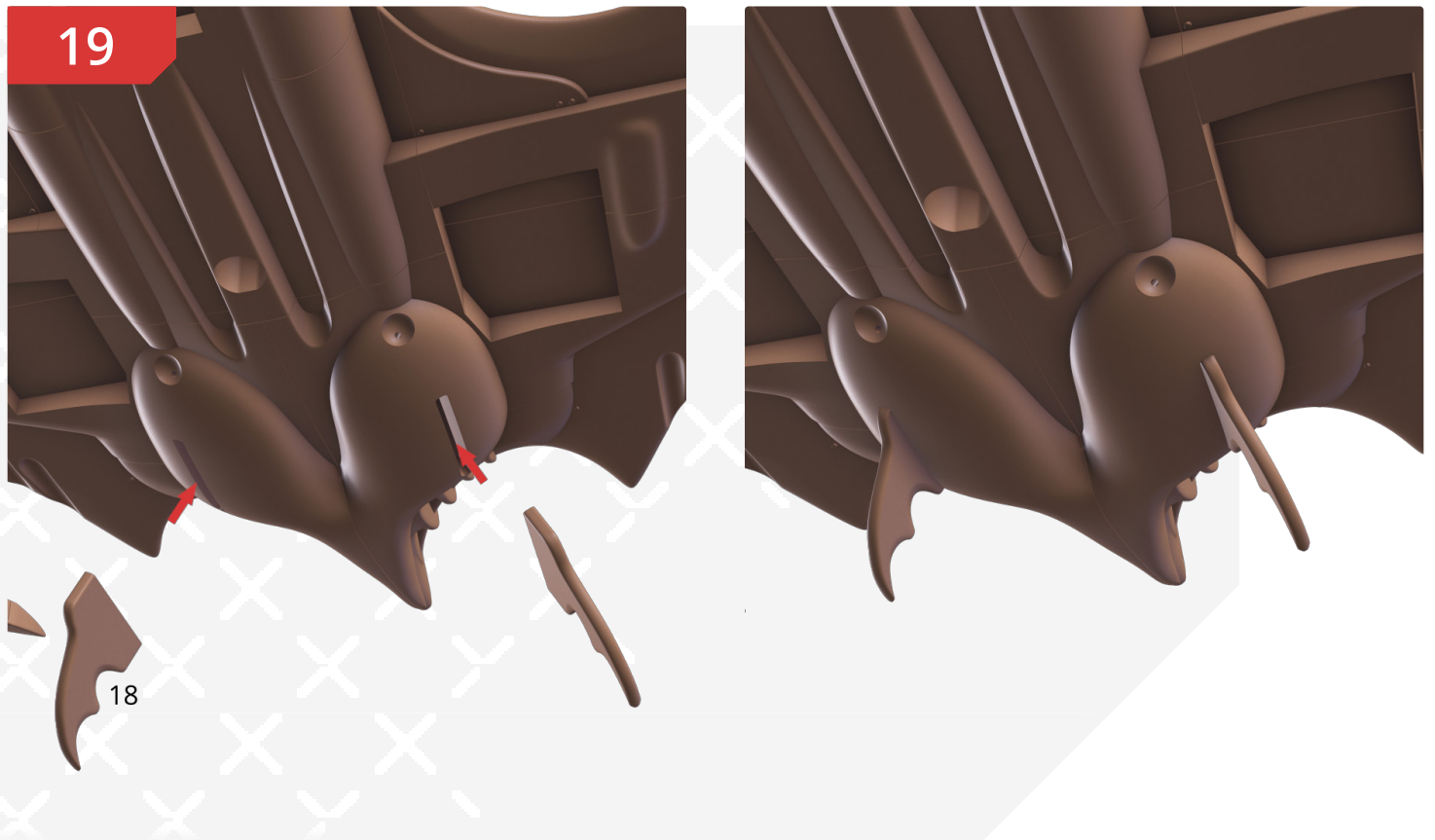

20



You can display Batwing 1989 on the extended landing gear or cover the slots for it with caps.



21

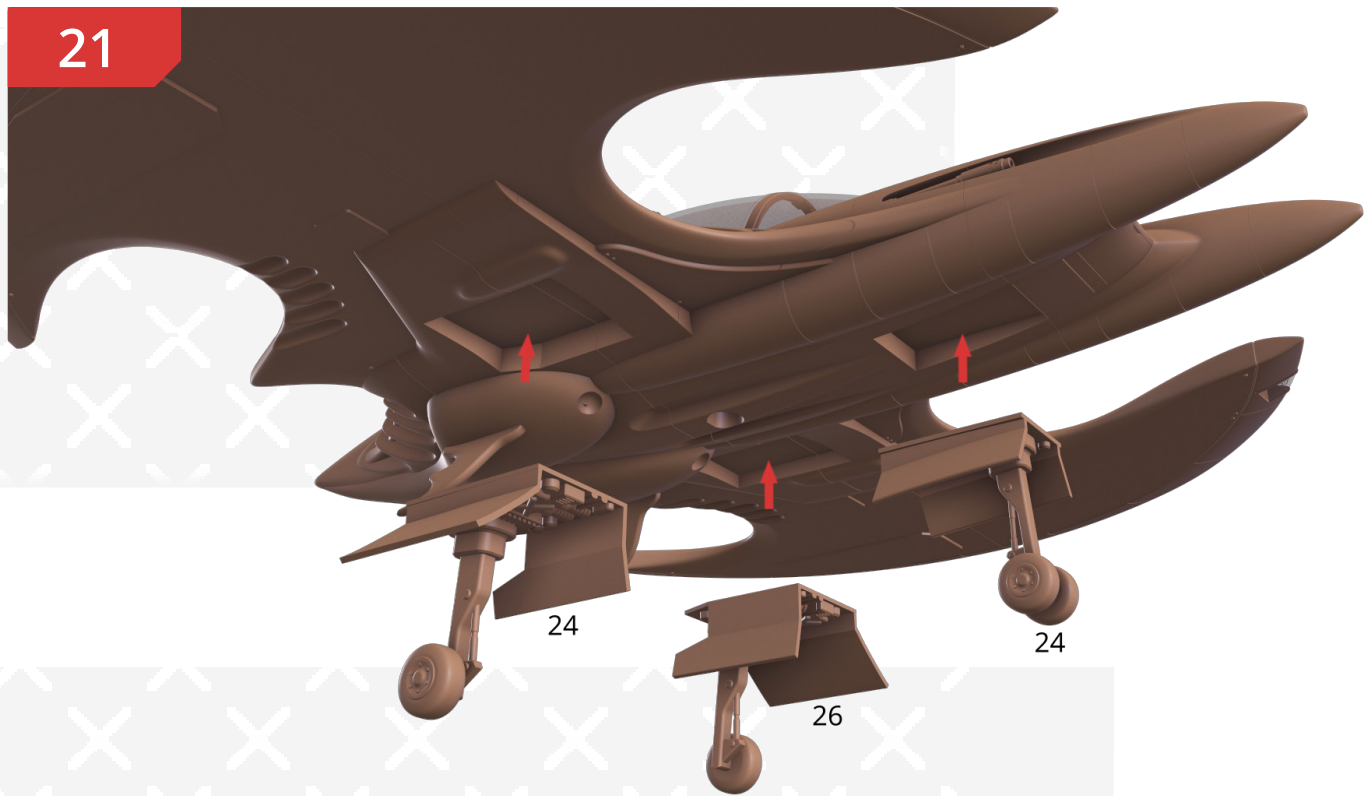

22

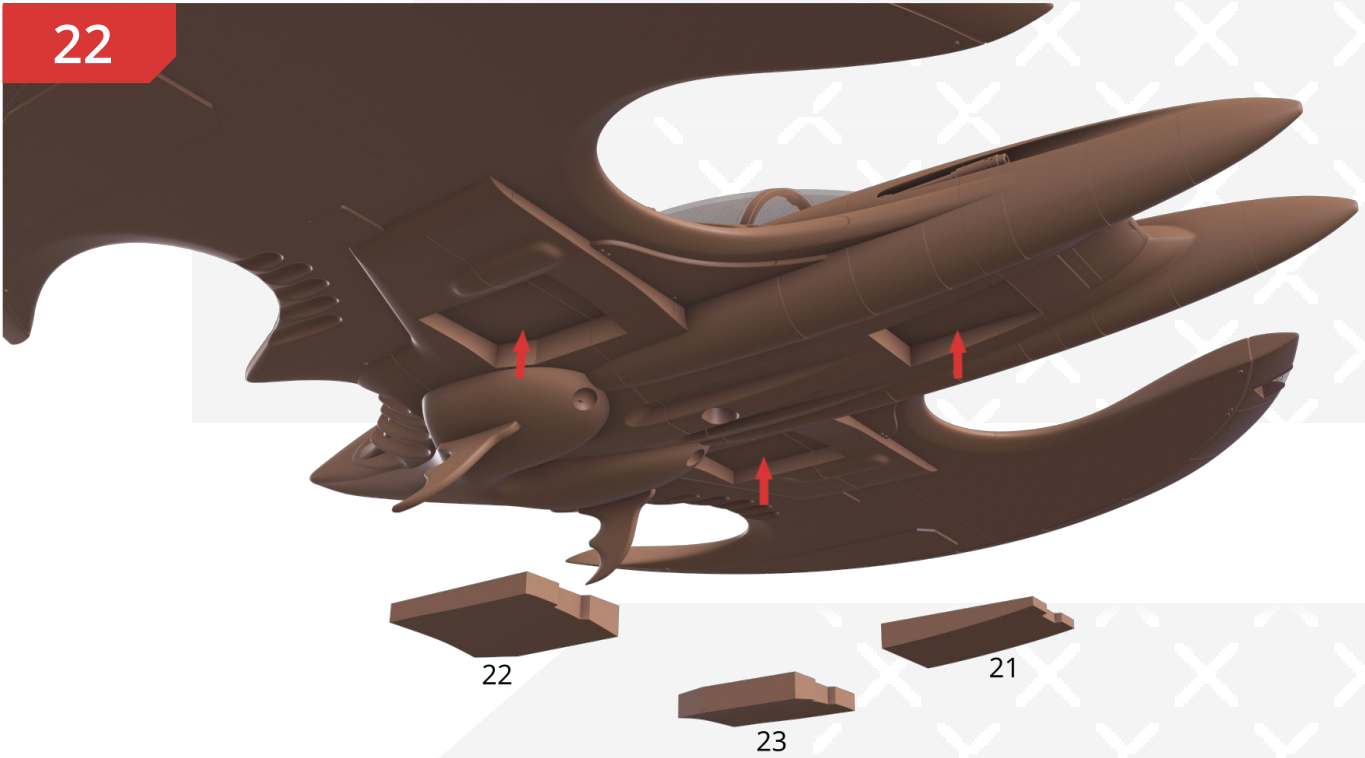

23



24

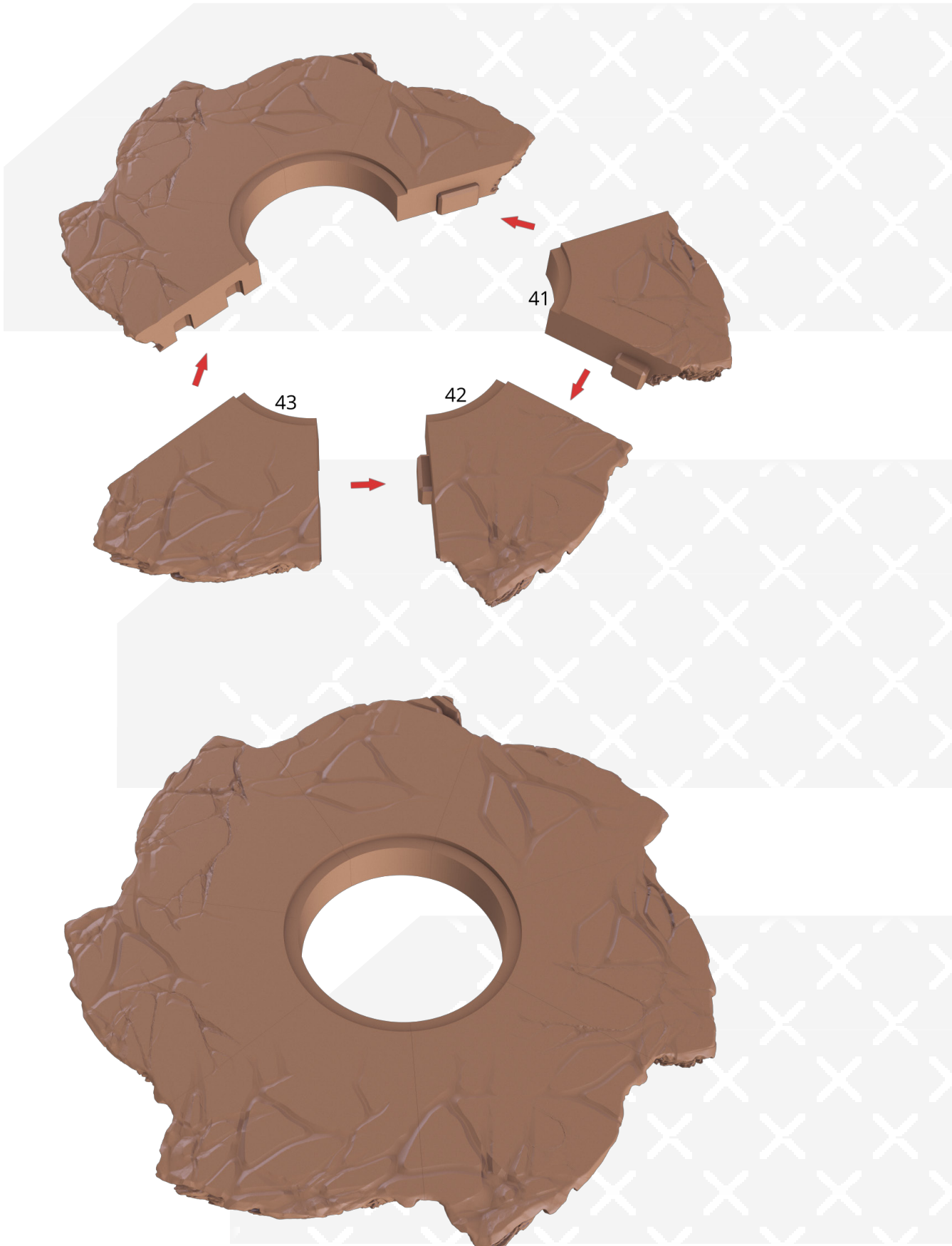

25



26



You can display Batwing 1989 in flight mode on a straight or a curved stand. Alternatively, you can cover the slot for the stand with a cap (part#5) and display the model on the extended landing gear.



STL files of all 3D printing models come with **full technical support** from **Gam**body team for life. If you have any questions or if you want to have any changes introduced, please, write to us at support@gambody.com.

Thank you for choosing
Gambody!

