

# GAIKING INSTRUCTION 1

Design by Reza Aulia  
Source: Toymakr3d.com

License: CC BY-NC-ND  
- Attribution - Non Commercial - No Derivatives



**SETTINGS:**  
Support : NO  
Nozzle: 0.4mm  
Layer: 0.15mm (0.1mm for the head)  
Filament: PLA+  
Temperature: 205°C  
Speed: 40 mm/s  
Skin/top/bottom: 0.8 mm  
Infill: 20-25%

# GAIKING INSTRUCTION 2

Design by Reza Aulia  
Source: Toymakr3d.com

License: CC BY-NC-ND  
- Attribution - Non Commercial - No Derivatives

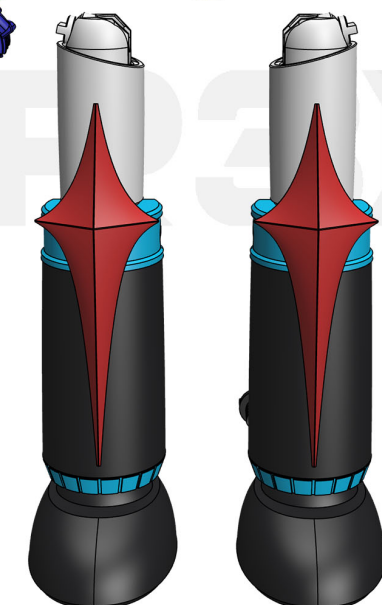
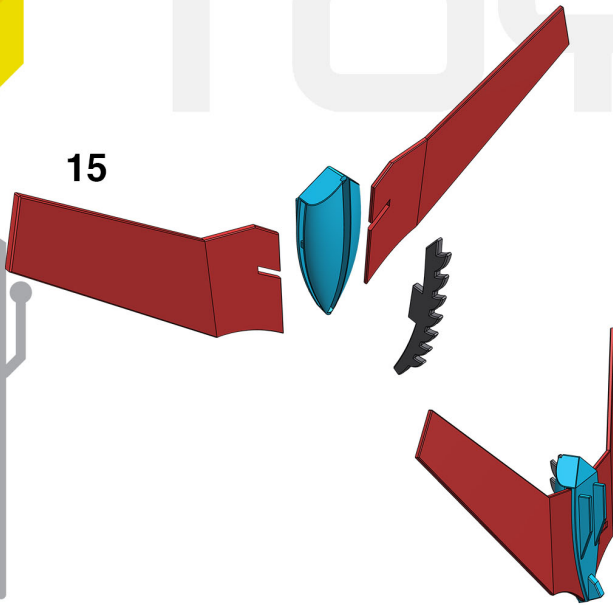
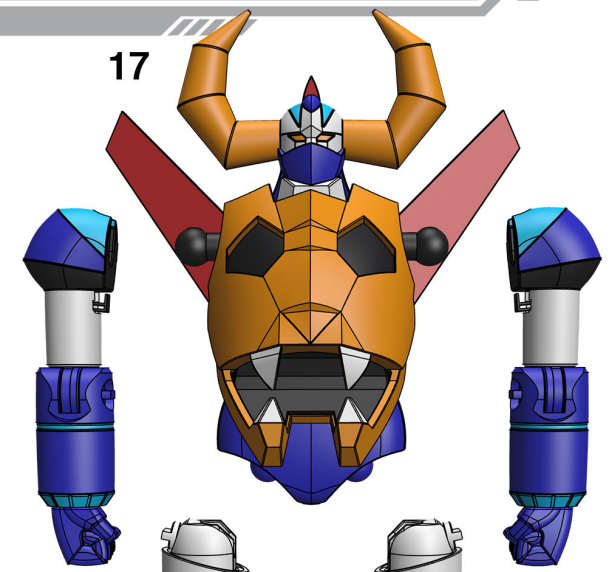
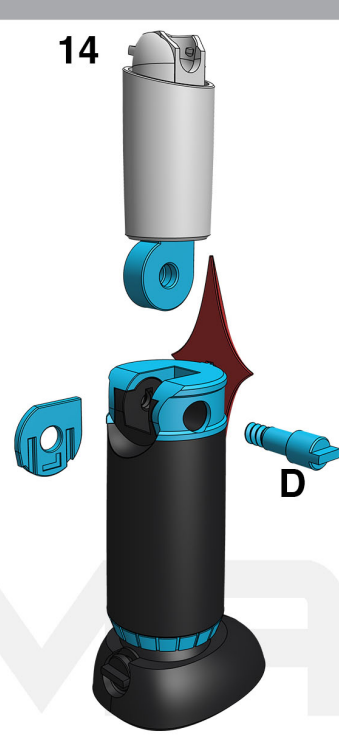

- **WARNING!:** Contains small parts and requires high precision. Your printer may need to be properly calibrated for best results. (Tolerances: Peg 0.15mm, Balljoint 0mm, Slide 0.3mm, Screw 0.4mm)
- **USE CLEAR NAIL POLISH TO TIGHTEN THE JOINTS:** Use it on both female and male ball joint or on friction joint surfaces. Wait until it dry before put them together
- **DISCLAIMER:** This model is for fan art purposes only. The creator is in no way associated with the original Gaiking character license owner.