

M4A3 Sherman 105 mm HOWITZER

Build guide

3D printed RC model of American medium tank (1944)

Scale: 1:10

Width: 266 mm

Height: 311 mm

Length: 602 mm

Weight: 5400 g

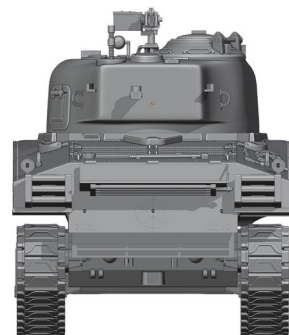
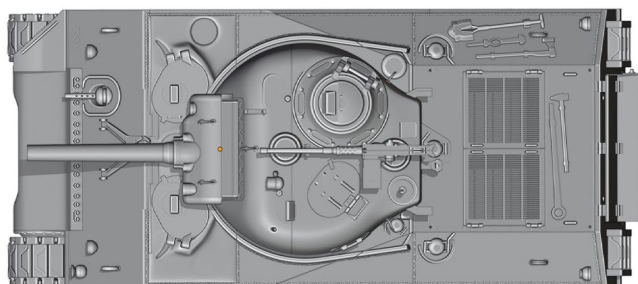
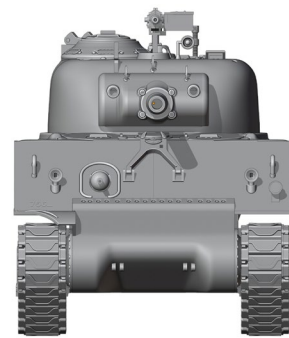
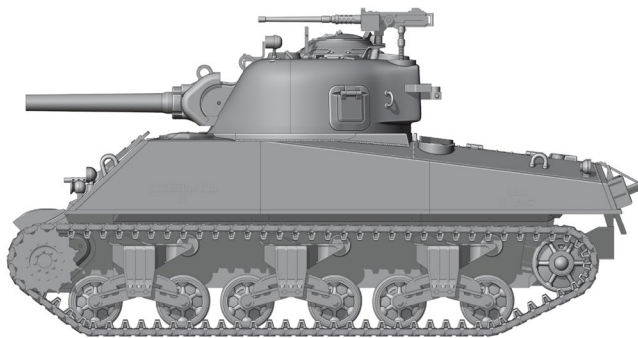

Author: **Luboš Hort**

Web: <https://3dtisk-rc-modely.webnode.cz>

E-mail: lubos_h@seznam.cz

version 1

Thank you for purchasing the tank model STL files. I tried to prepare the parts as carefully as possible with regard to simplicity and possible repairability.

Some parts may not exactly match the illustrations in this manual.

These are later modified or improved parts. Please follow the [updates](#).

What you need:

- 3D printer with buildplate 20x20 cm and 5 kg PLA
(4 kg of green and 1 kg of black)
- Ball bearings: 10x15x4 (14 pcs), 15x21x4 (4 pcs), 6x13x5 (4 pcs)
- brushed motor 540 16T (2 pcs)
- standard servo (1 pcs standard + 1 pcs 360° - possible modification of standard servo)
- small high speed servo (1 pcs) main gun recoil - optional
- ESC for brushed motors 45-60A (2 pcs)
- rezistor 2k7 ohm for servo modification to 360° (2 pcs)
- 2S1P Li-Po battery 7,4 V (2 pcs)
- M2 screws: 8 mm - 50 pcs, 10 mm - 18 pcs, 6 mm - 20 pcs
- M3 screws: 8 mm - 13 pcs, 10 mm - 20 pcs, 12 mm - 12 pcs, 14 mm - 2 pcs, 20 mm - 18 pcs, 30 mm - 2 pcs
- M3 nuts (10 pcs)
- M3 headless screws (4 pcs)
- brass wire 1,5 mm, length 45 mm - 316 pcs (track connection, 15 pcs x 1m)
- wires 1,2 mm (stronger paper clip, etc.)
- brass tube 6 mm, length 30 mm (12 pcs) and 43,5 mm (2 pcs)
- brass tube 4 mm, length 48 mm (12 pcs), 29 mm (6 pcs)
- washers 6,4x12x1,6 (24 pcs)
- spring 7,5x21-23x0,8 mm (6 pcs)
- medium viscosity superglue (BOLT) and actinator (spray)
- grease, colors, varnish, etc.
- TX and RX (OpenTX is the best choice)
- LED 5 mm - 3x warm white, 2x red
- LED light RC module

Recommended setup for 3D print:

nozzle: 0,4-0,5 mm

extrusion width: 0,5 mm

layr height: 0,15 mm

perimeters: 2

infill: 50 % (tooth gears, and stronger parts 96%)

temperature: HE 220°C, HB 50°C

printing speed: 50 mm/s, external perimeters 30 mm/s

Try to print gears with one or two perimeters, there may be and difference.

Locate the best place for seam position on each part.

Most parts print without supports.

Where support is needed, the name includes “support”.

If you need to print more than one piece,

quantity is also mentioned in the title.

This is my recommended printer setting,

however, you can also use your proven ones.

Before gluing the parts, test their fitting.

Use and fine metal filer, sharp knife or sandpaper to

align the contact surfaces.

The most common problem is the “elephant’s foot” –

the expansion of printed parts on the build plate.

It must be removed.

More pictures and videos you can find [here](#) and [here](#).

M4A3 Sherman – Build Guide

← use glue
← do not glue

Wheels:

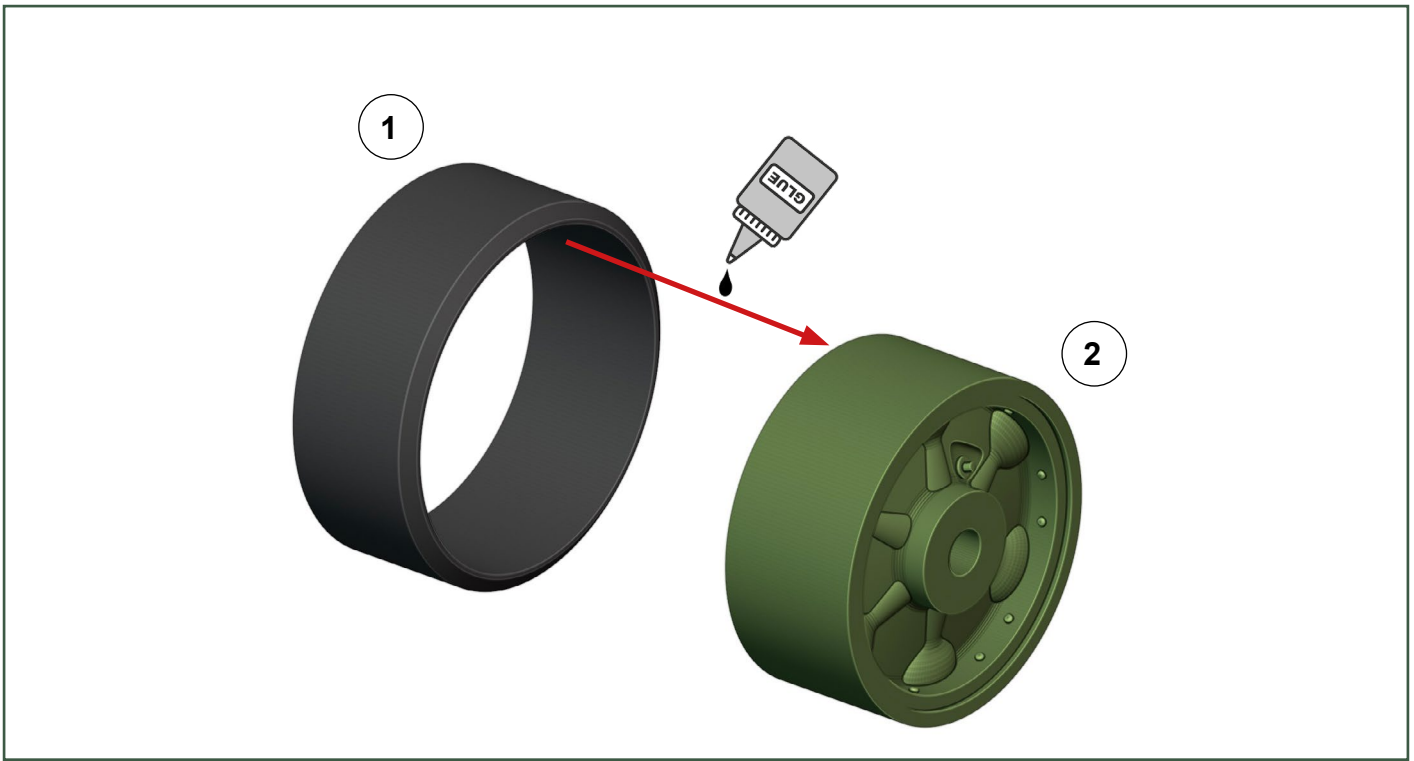

Wheels:

2x screw M2 8 mm

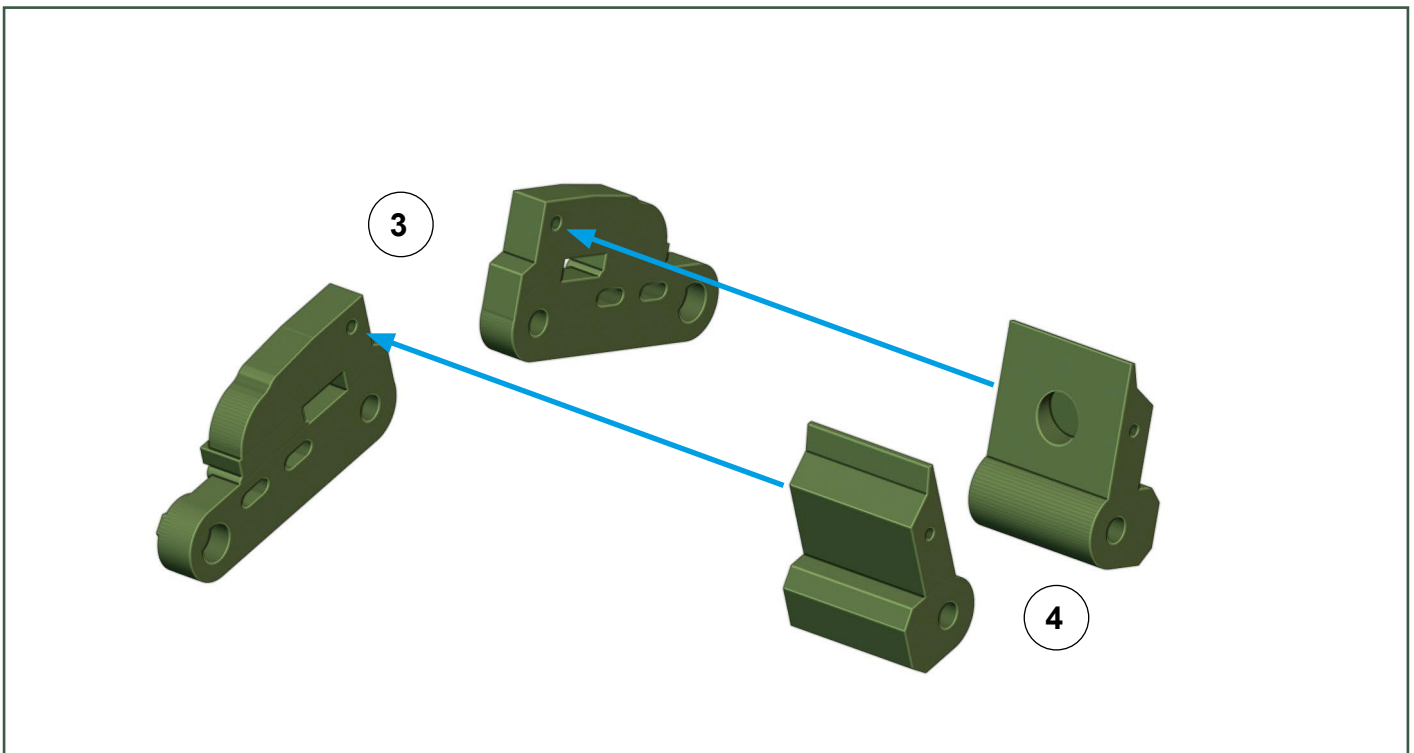

M4A3 Sherman - Build Guide

Wheels:

2x tube 6x30 mm

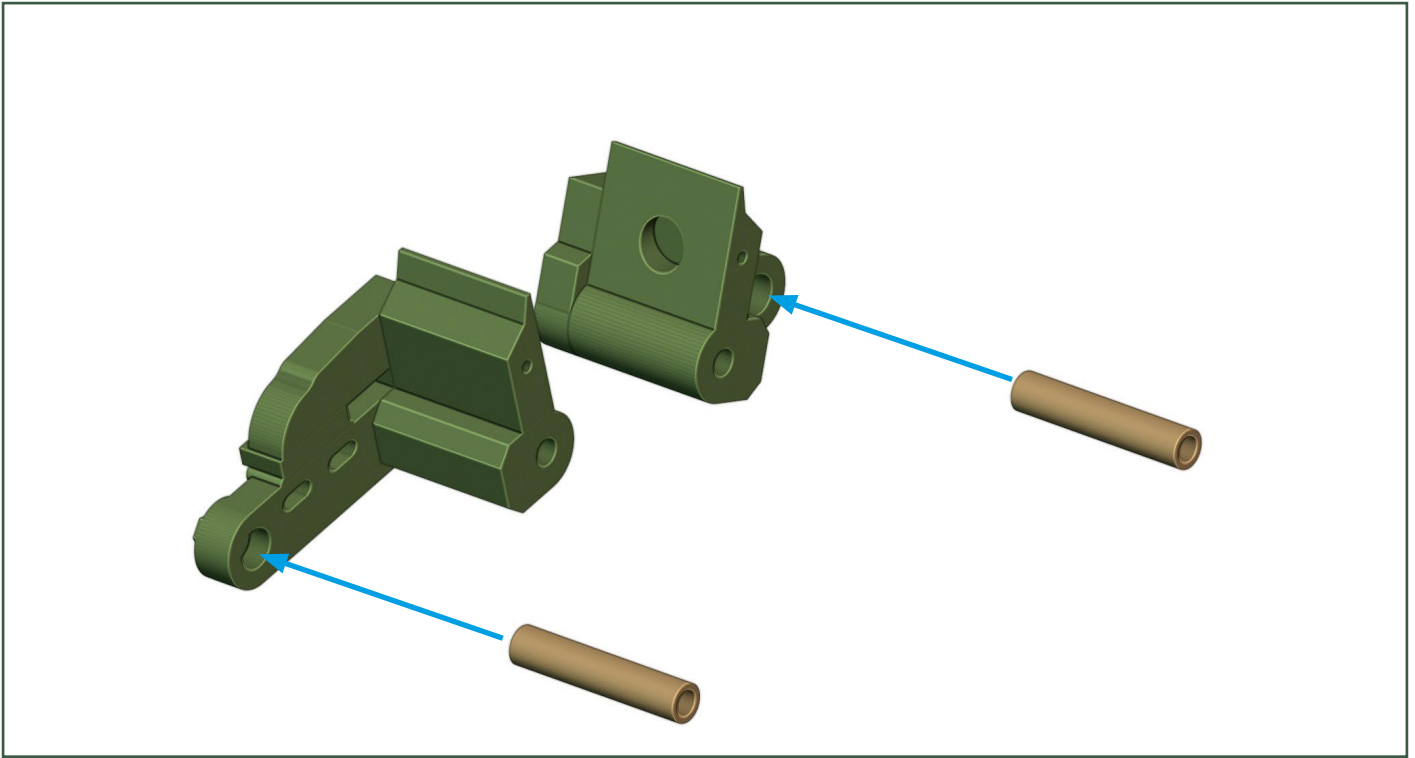

Wheels:

2x washer 6,4x12x1,6 mm

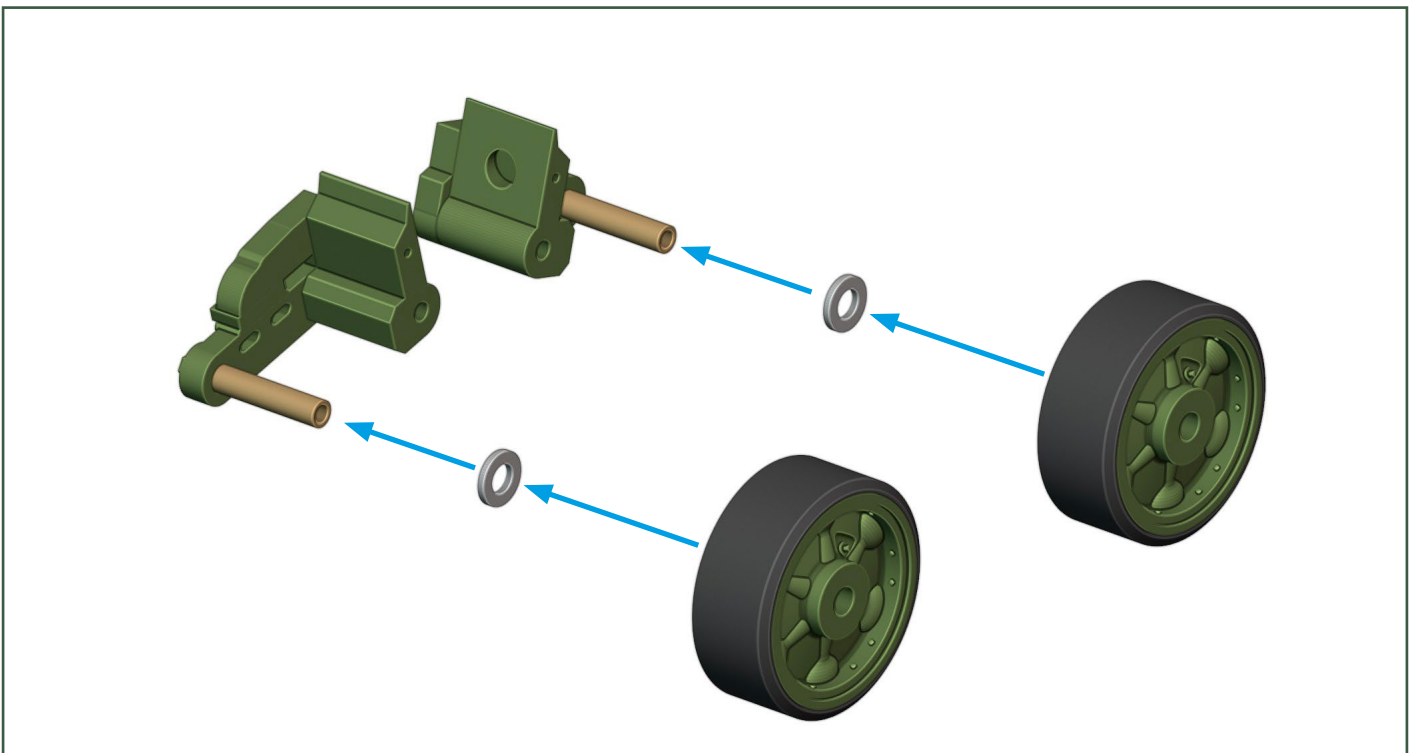

M4A3 Sherman – Build Guide

Wheels:

2x washer 6,4x12x1,6 mm, 6x, 2x screw M2 8 mm

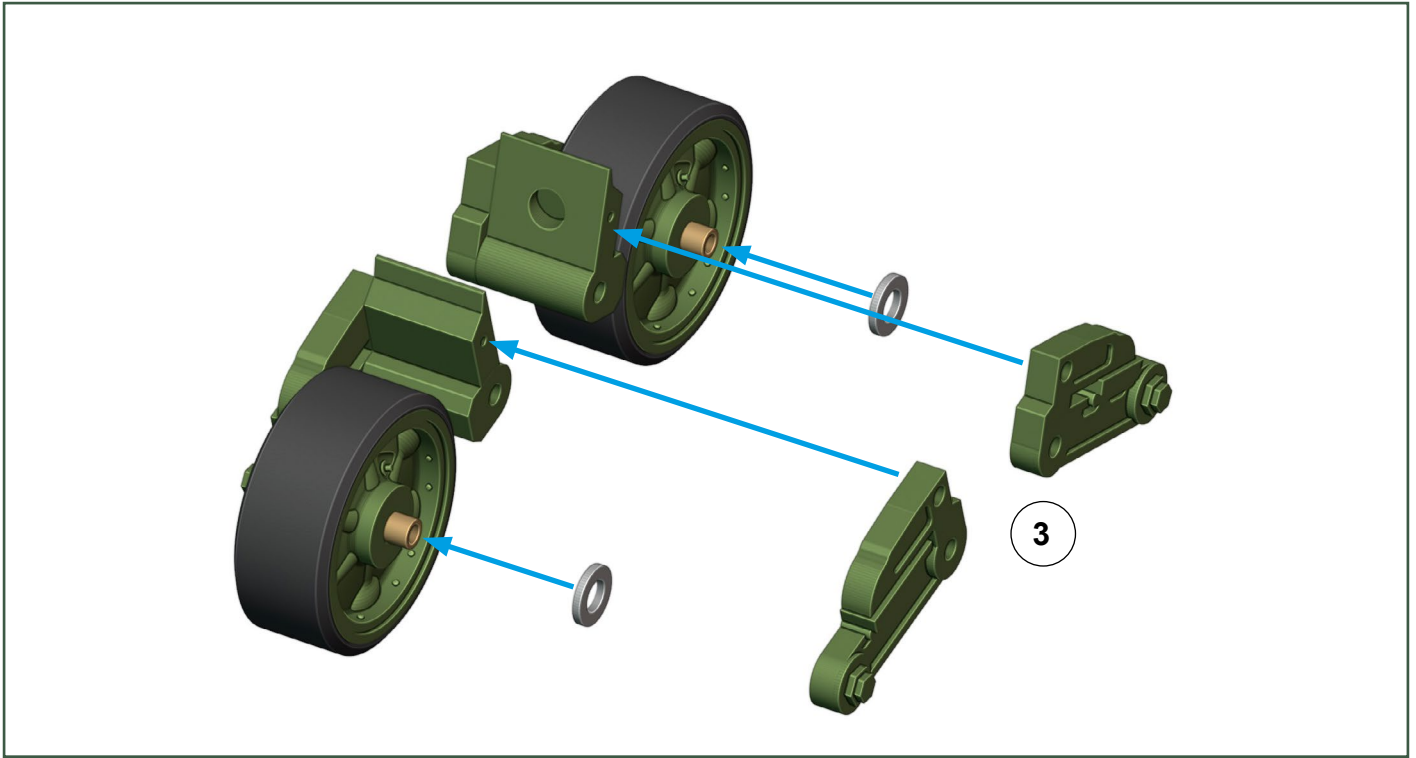

Wheels:

part 5 - 3x for the left side and 3x for the right side

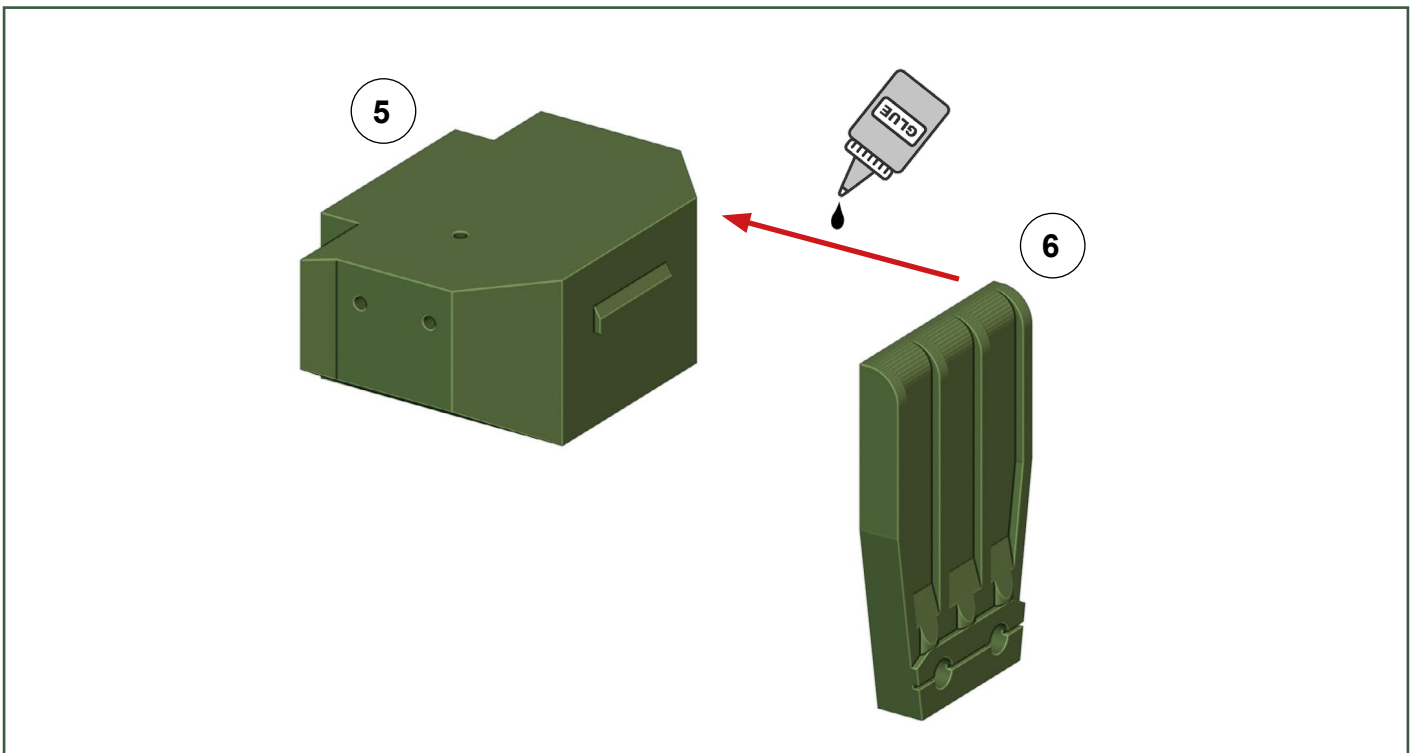

M4A3 Sherman - Build Guide

Wheels:

2x tube 4x48 mm, spring 7,5x21x0,8 mm

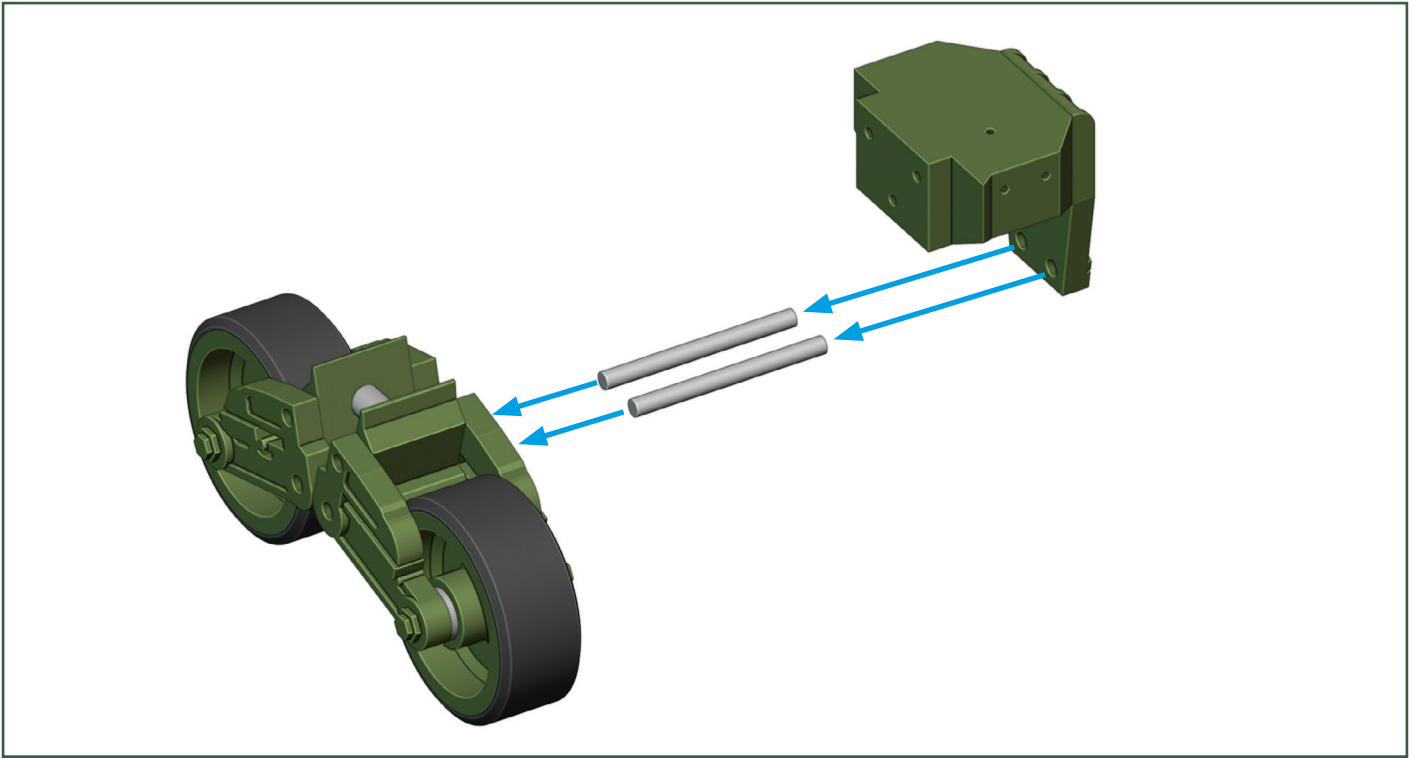

Wheels:

do not connect with screws yet

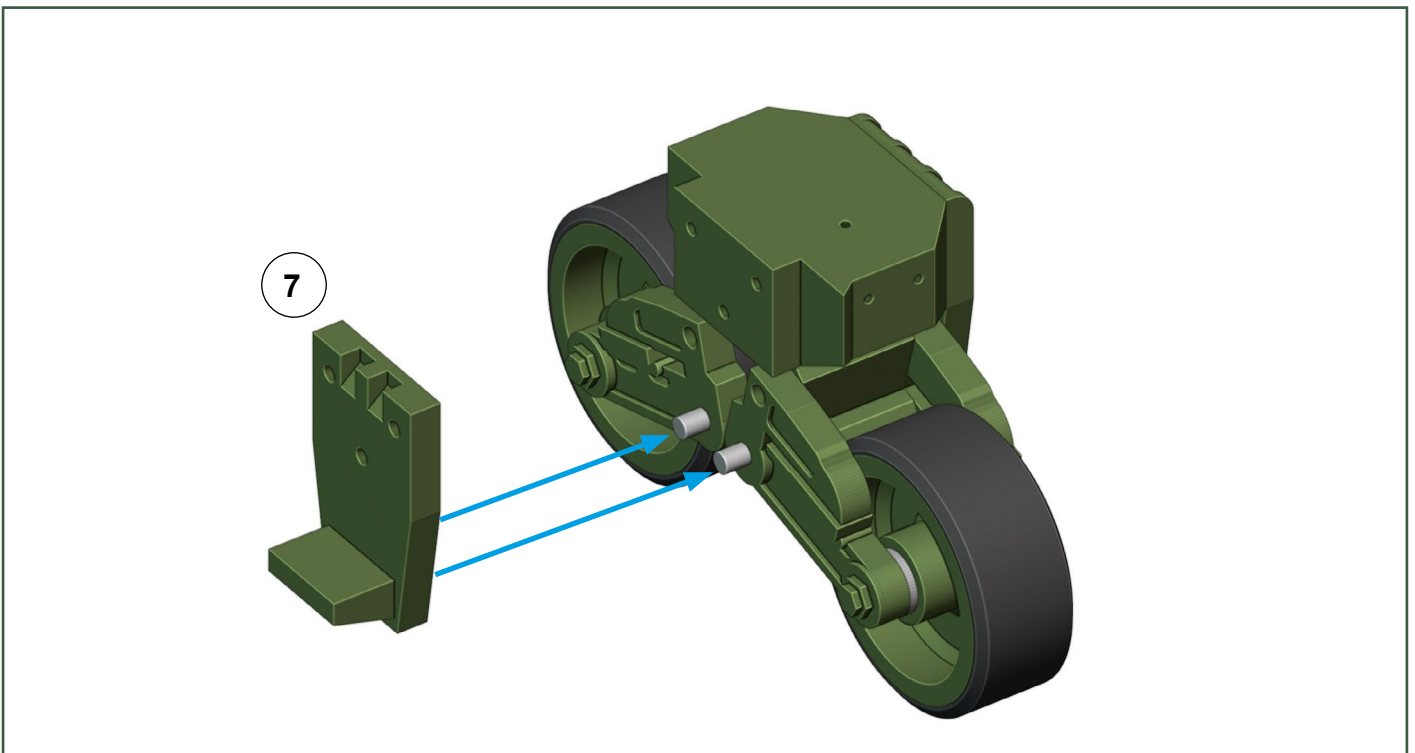

M4A3 Sherman - Build Guide

Wheels:

part 8 - 3x for the left side and 3x for the right side

2x M2 screw 10 mm

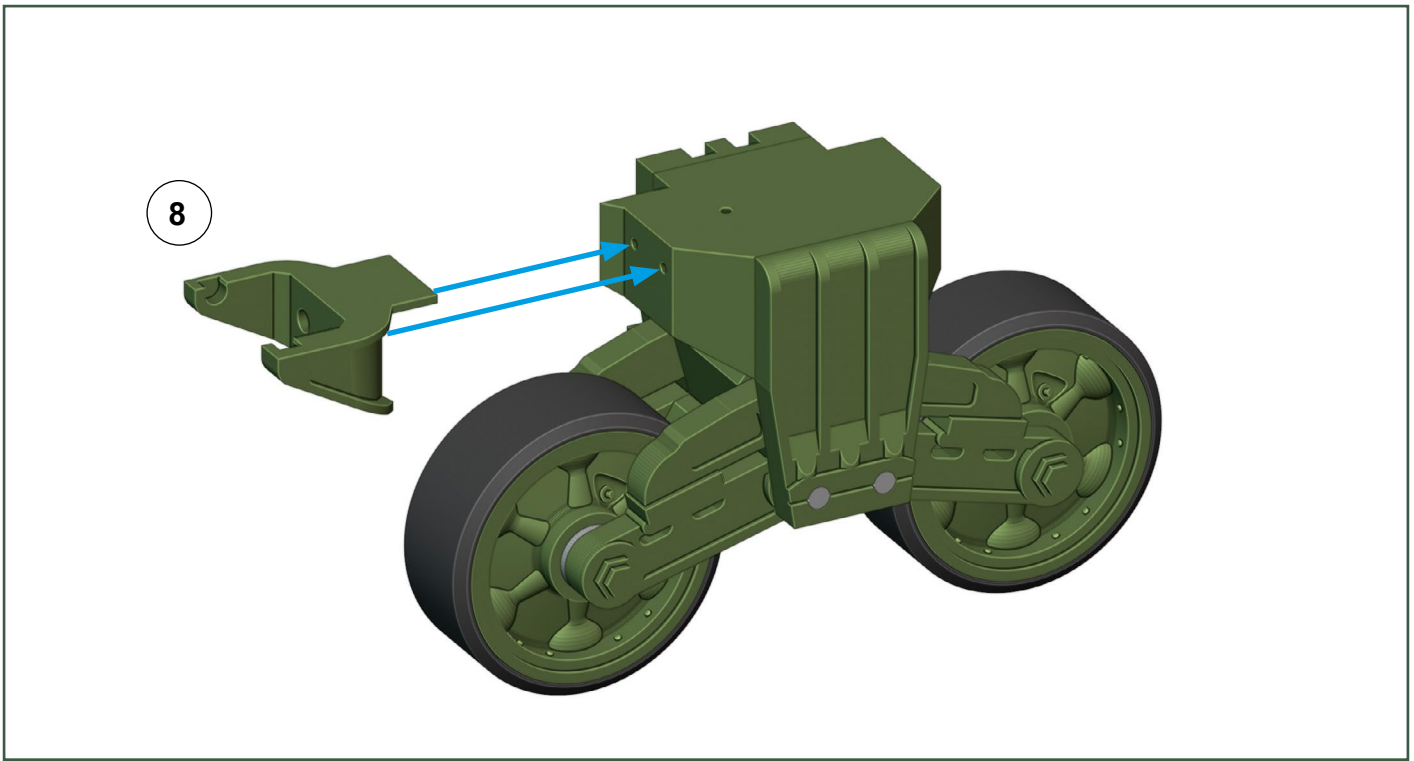

Wheels:

tube 4x29 mm, M2 screw 6 mm

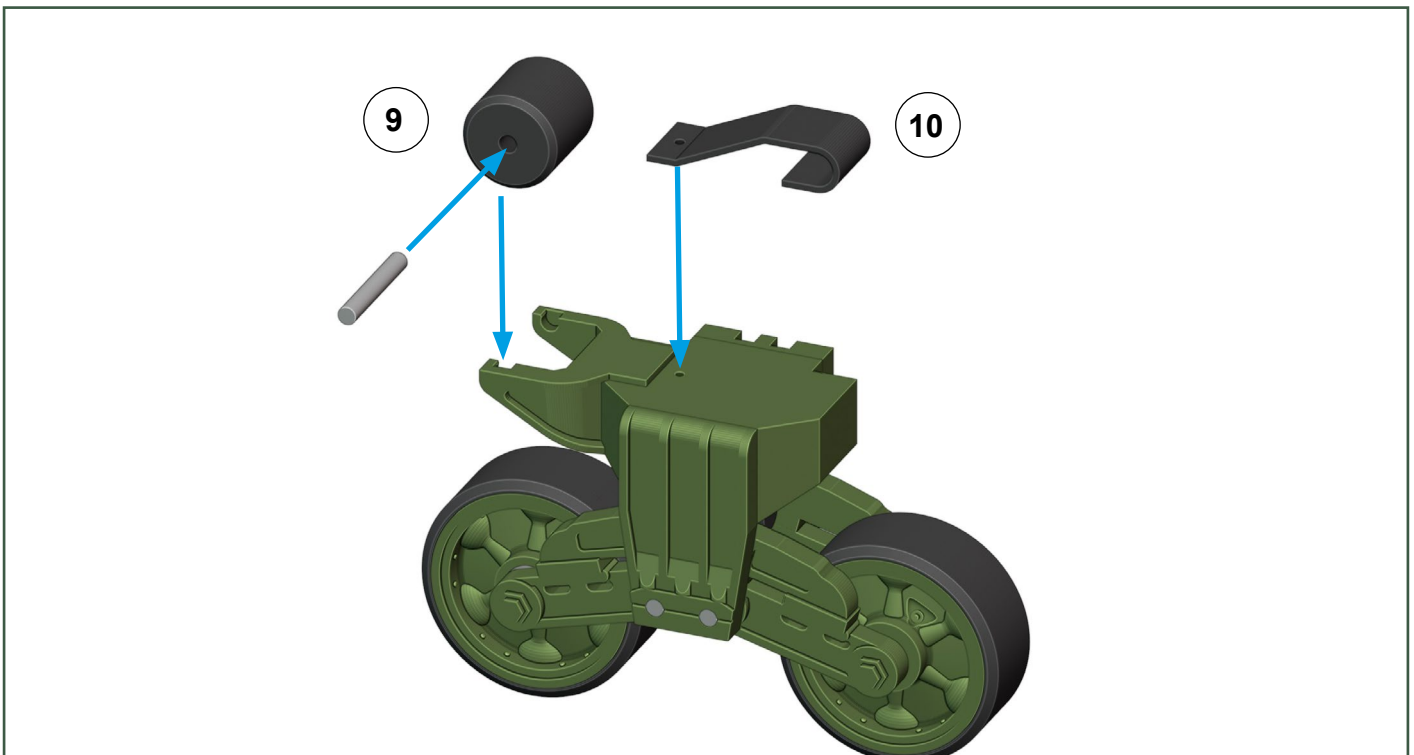

M4A3 Sherman – Build Guide

Wheels:

wheel's collection - 3x left and 3x right



Wheels:

3x M3 screw 10 mm

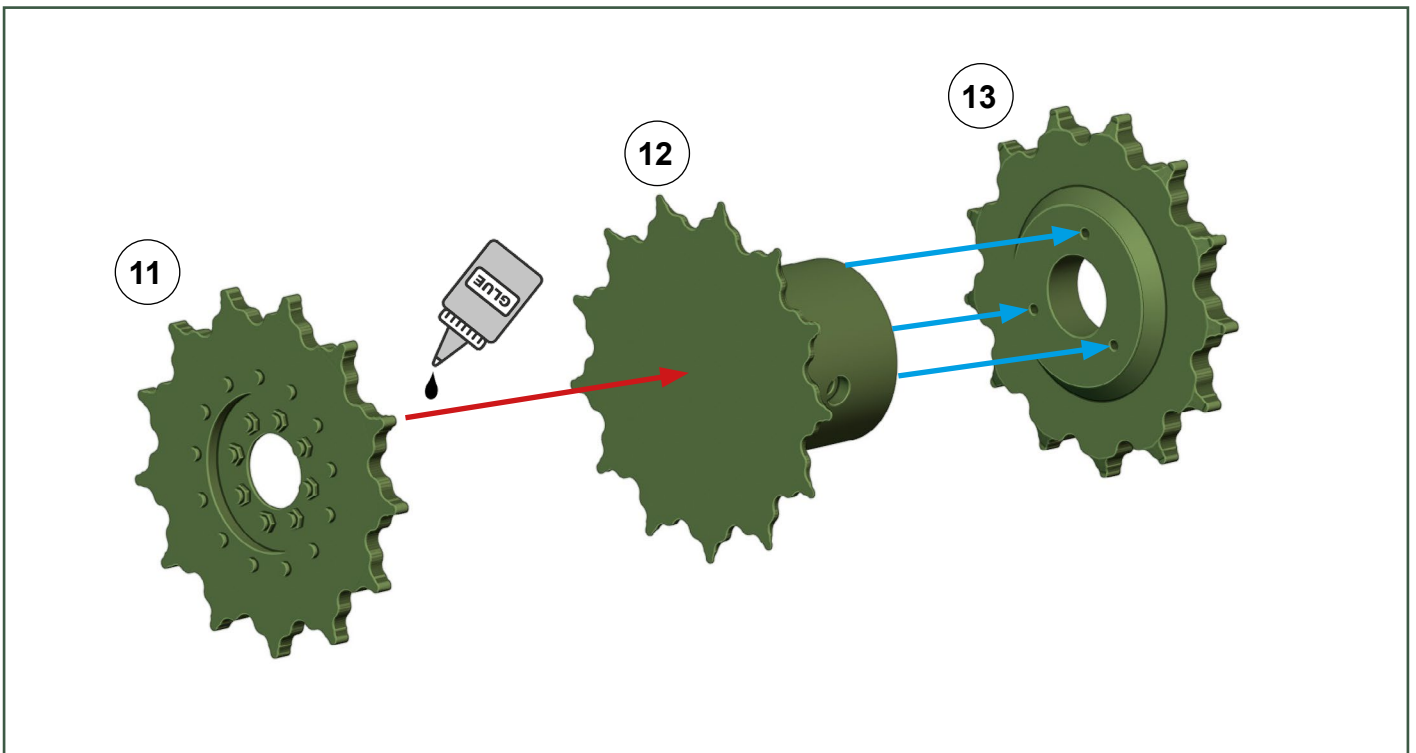

M4A3 Sherman - Build Guide

Hull:

right wheel block, 3x M3 screw 20 mm

← use glue

← do not glue

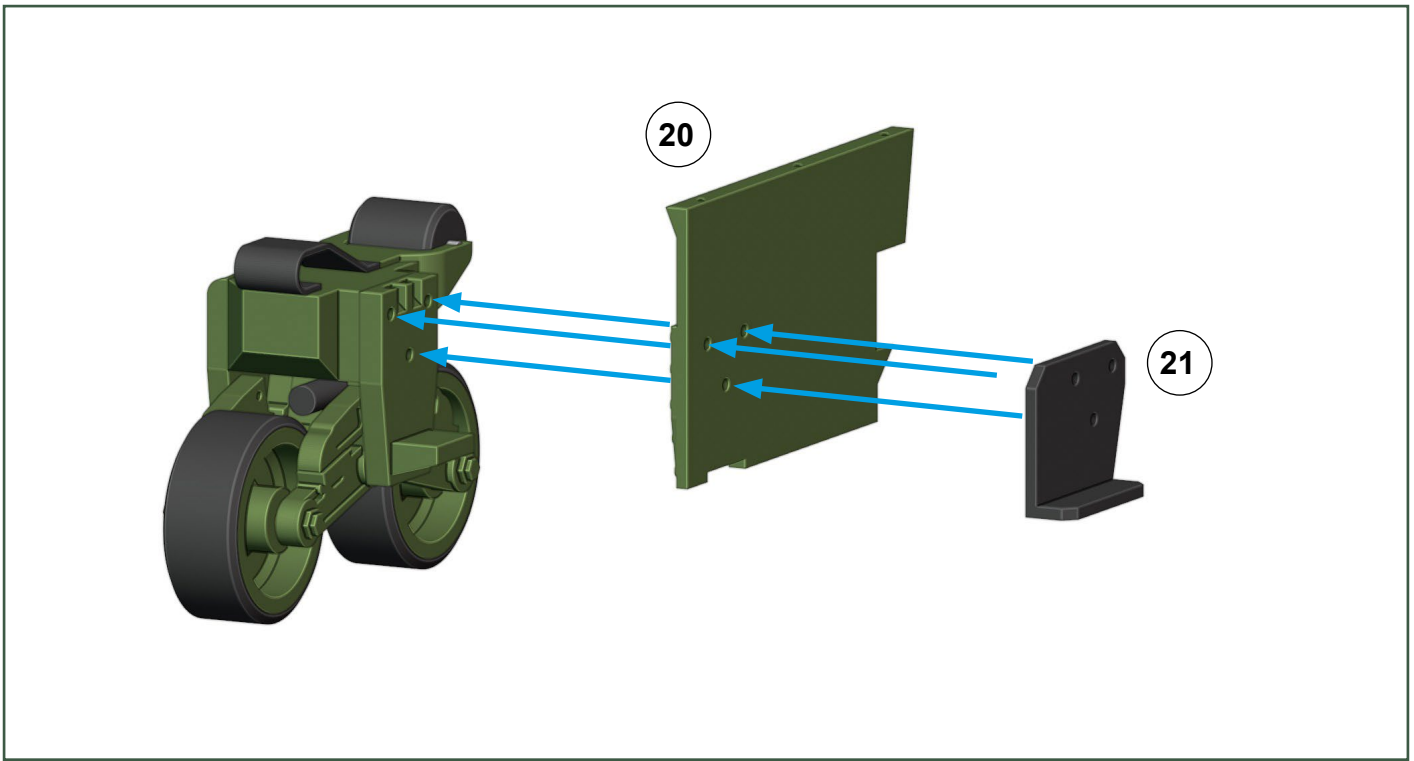

Hull:

2x M2 screw 8 mm

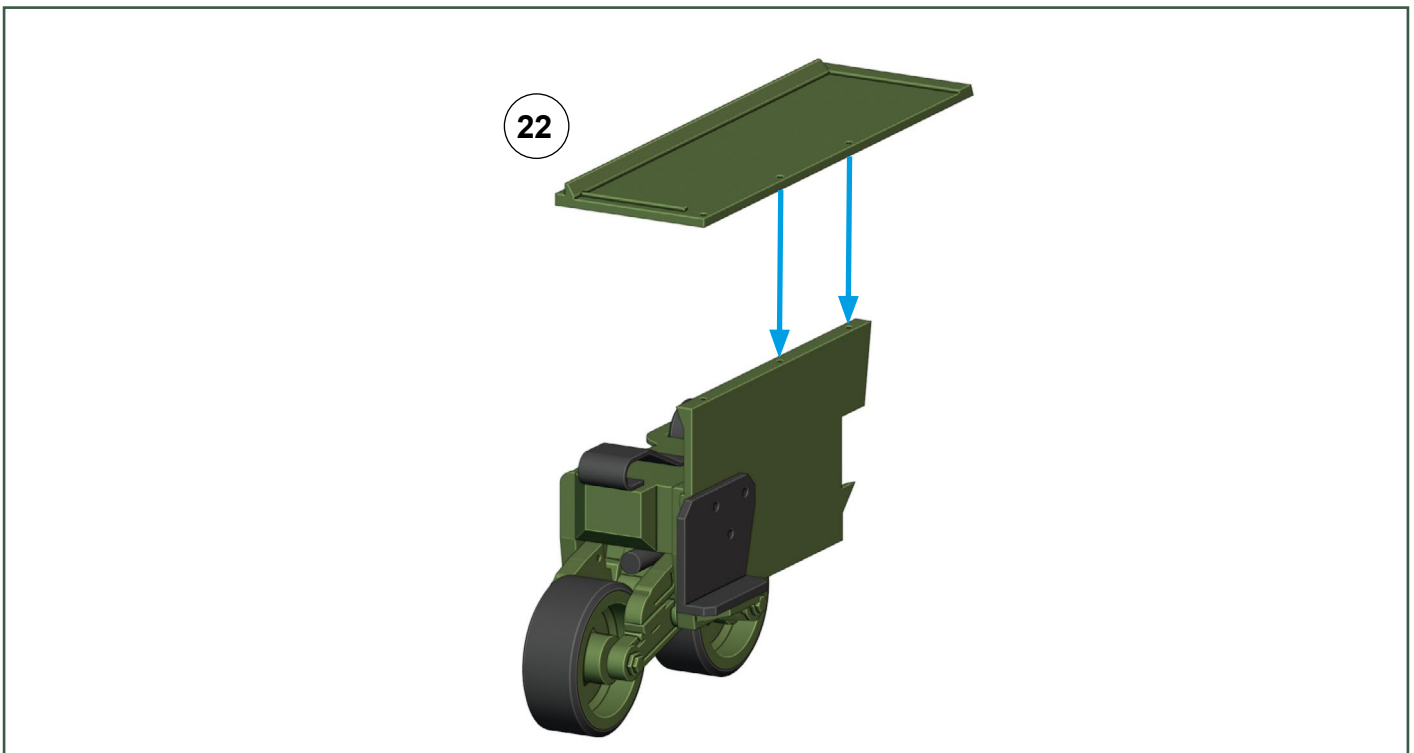

M4A3 Sherman - Build Guide

Hull:

left wheel block, 3x M3 screw 20 mm

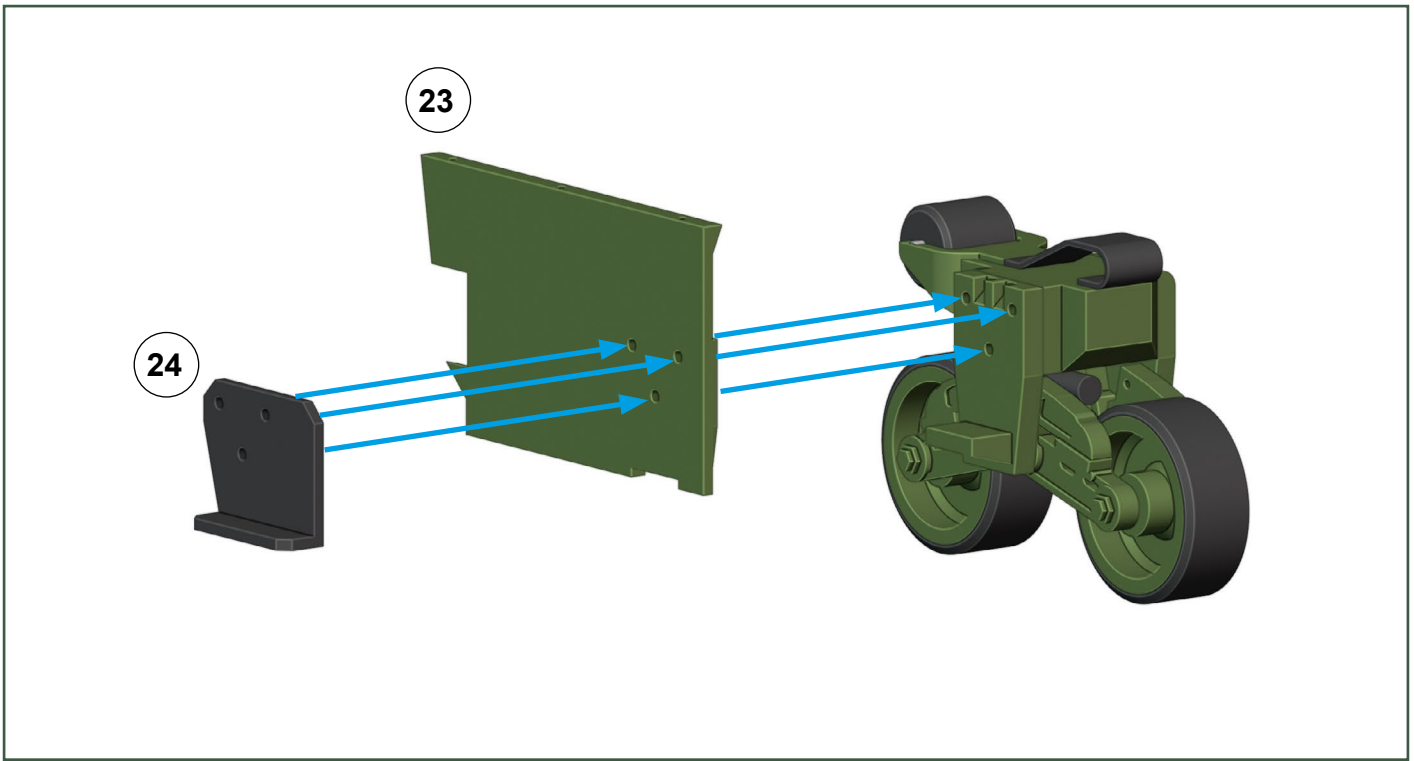

Hull:

2x M2 screw 8 mm

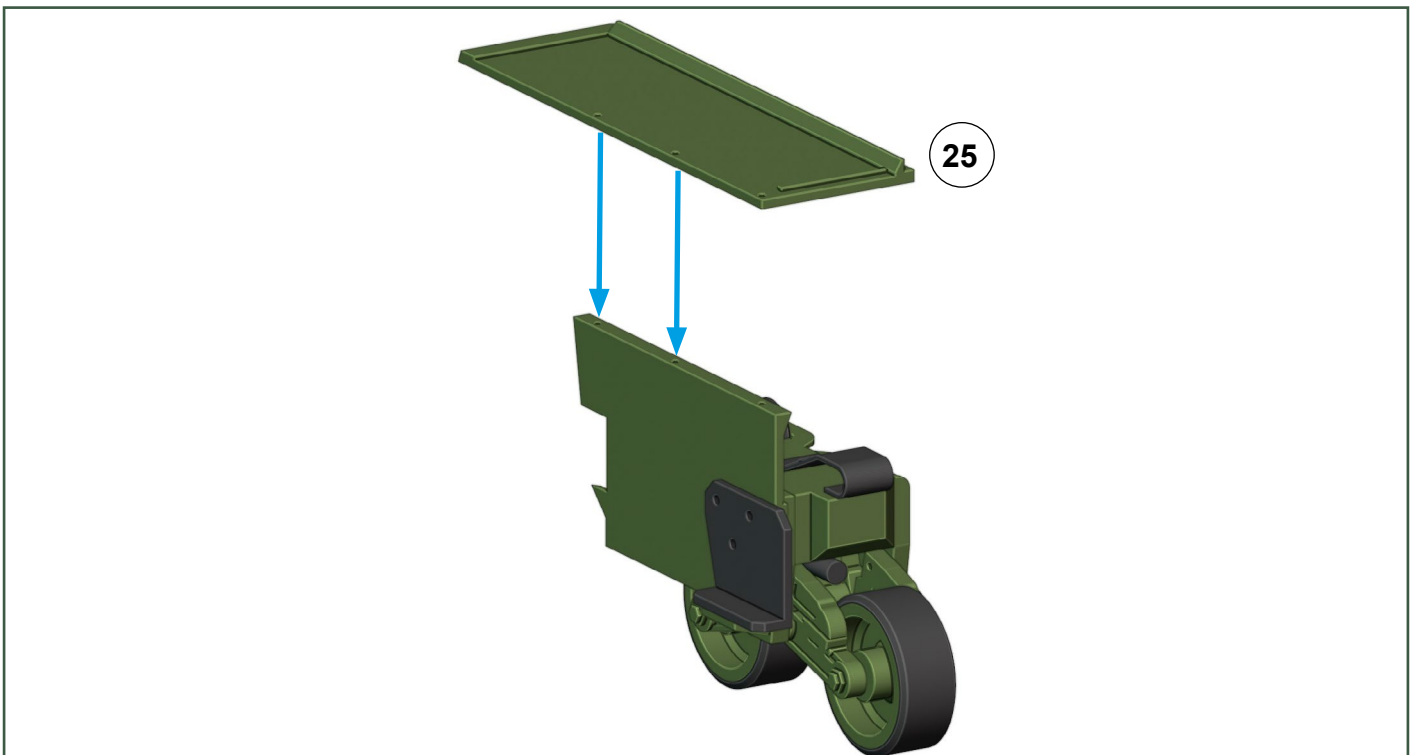

M4A3 Sherman - Build Guide

Hull:

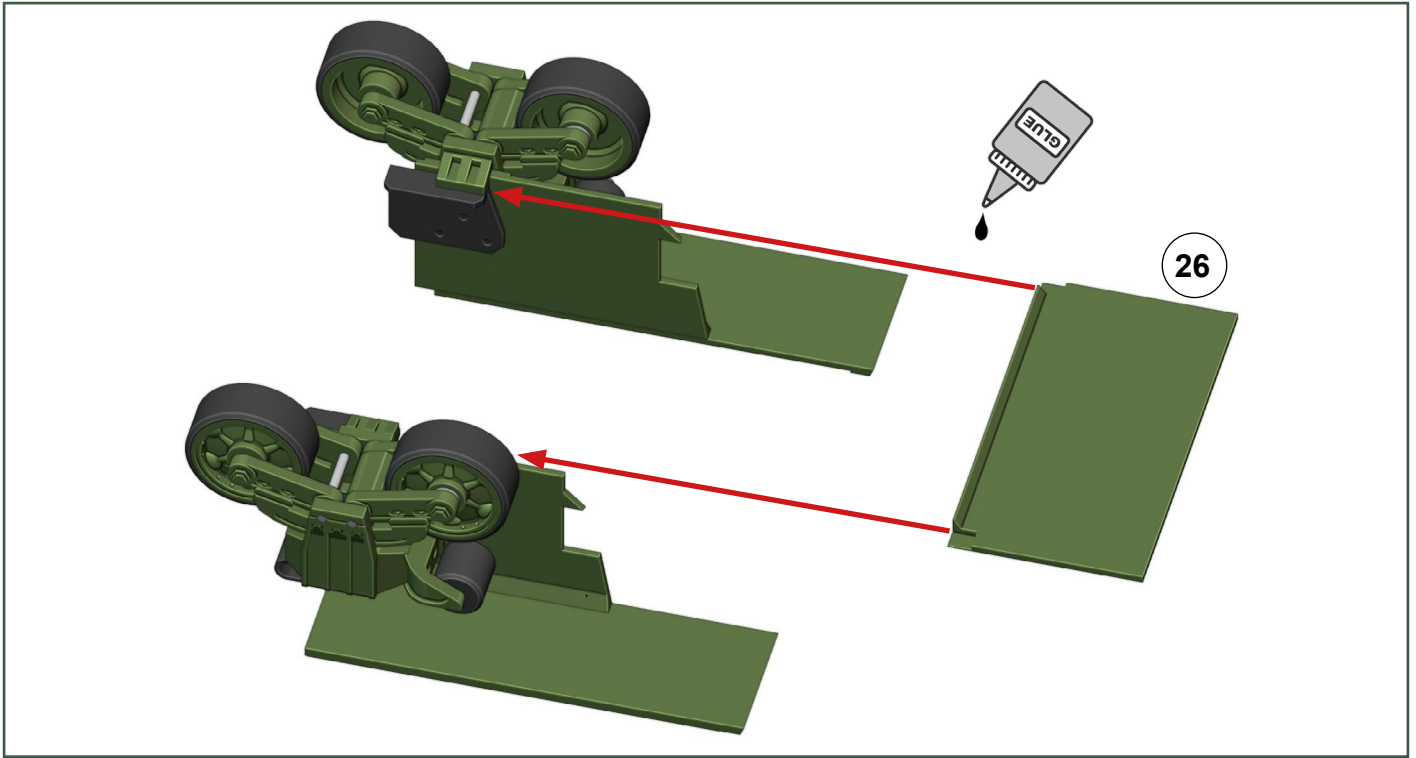

Hull:

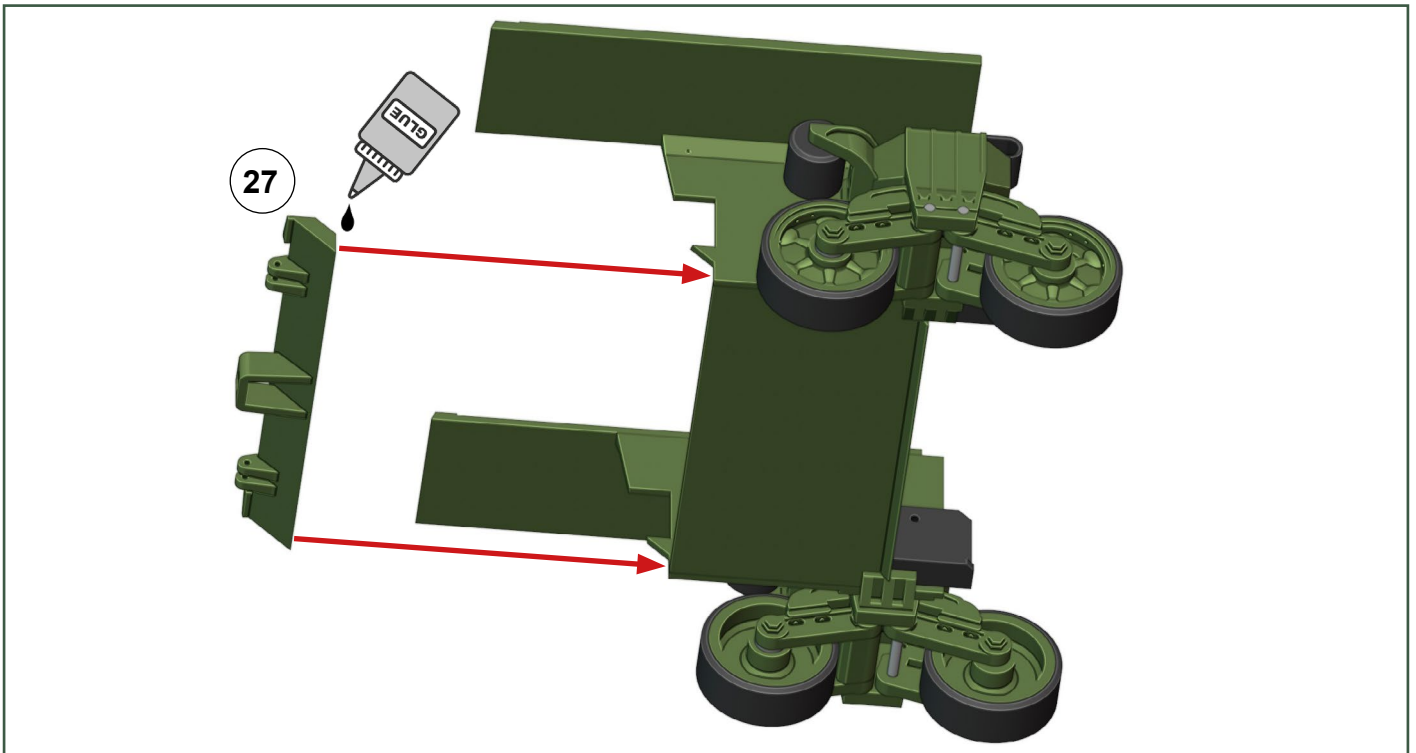

M4A3 Sherman - Build Guide

Hull:

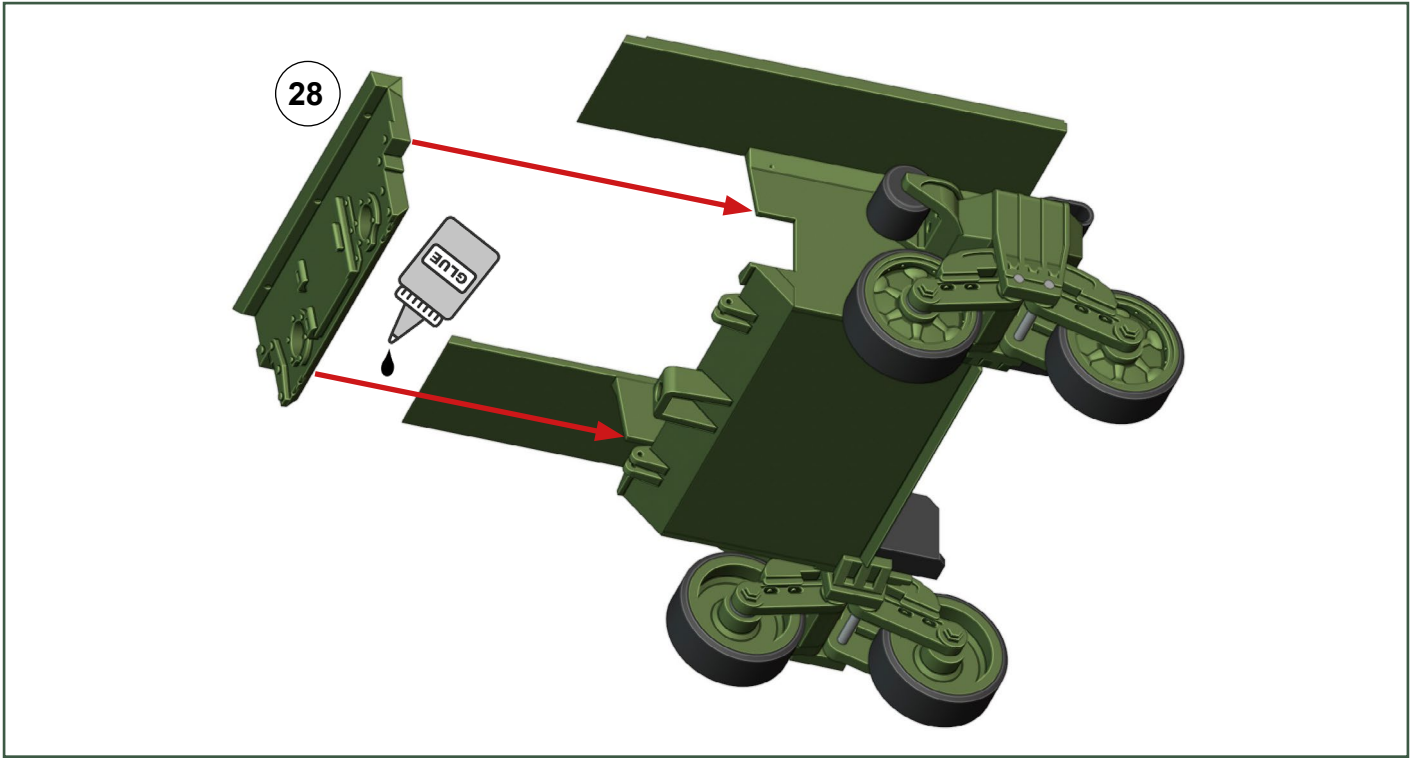

Hull:

3x M3 screw 8 mm

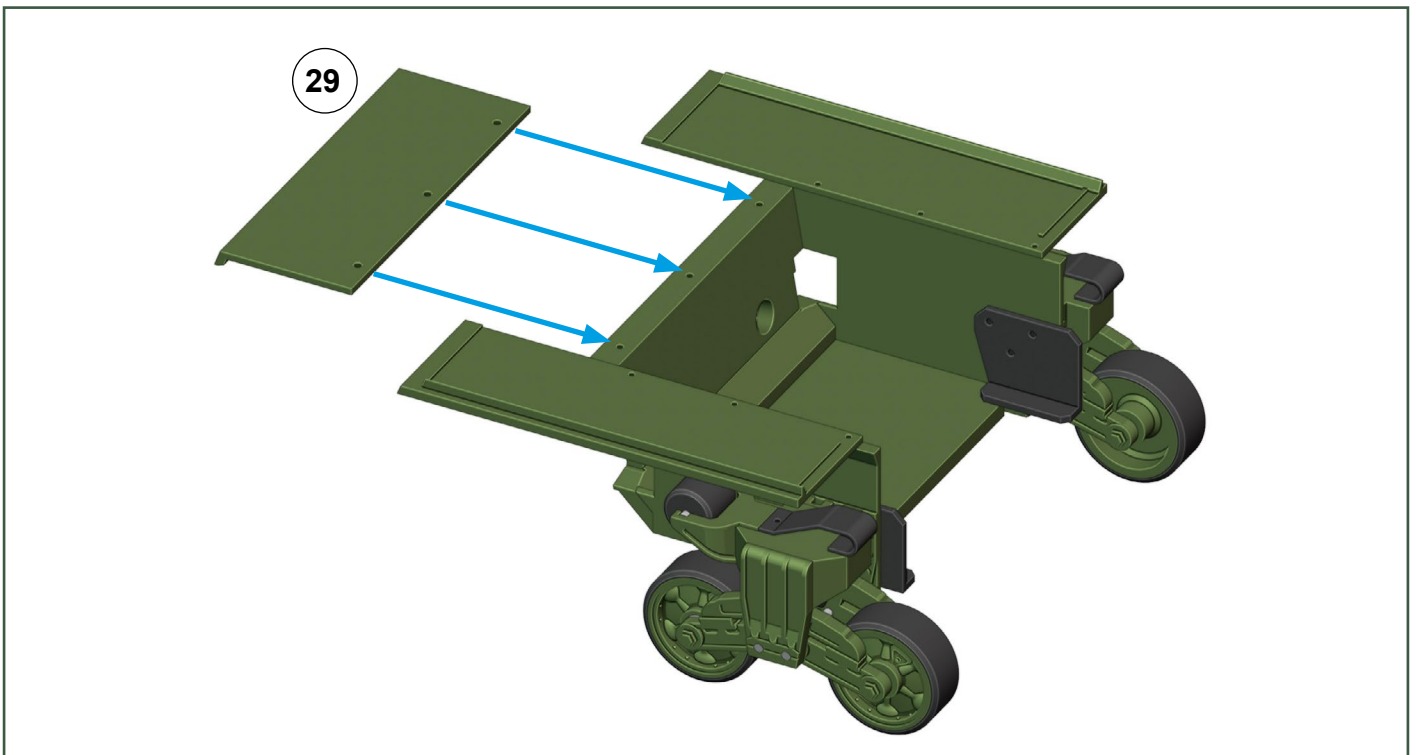

M4A3 Sherman - Build Guide

Hull:

3x M2 screw 8 mm

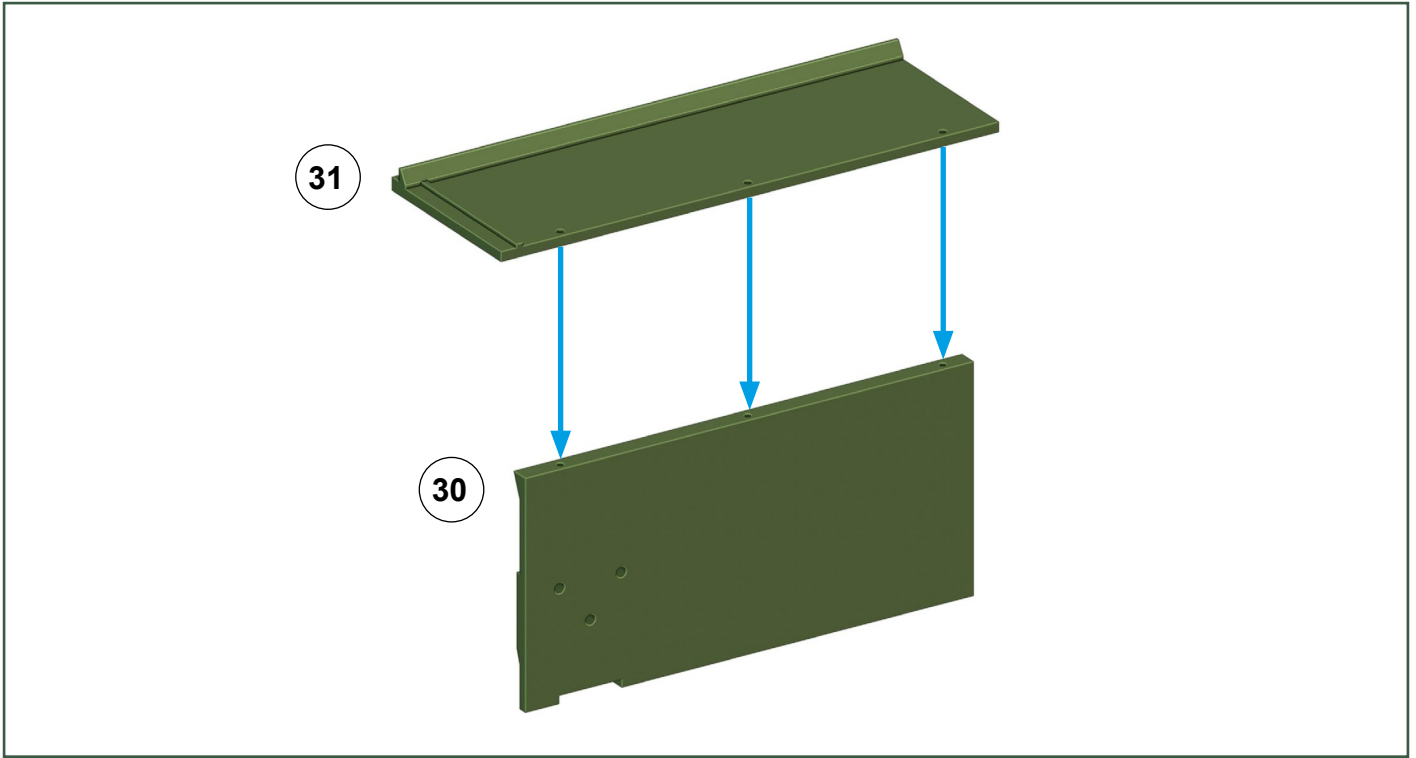

Hull:

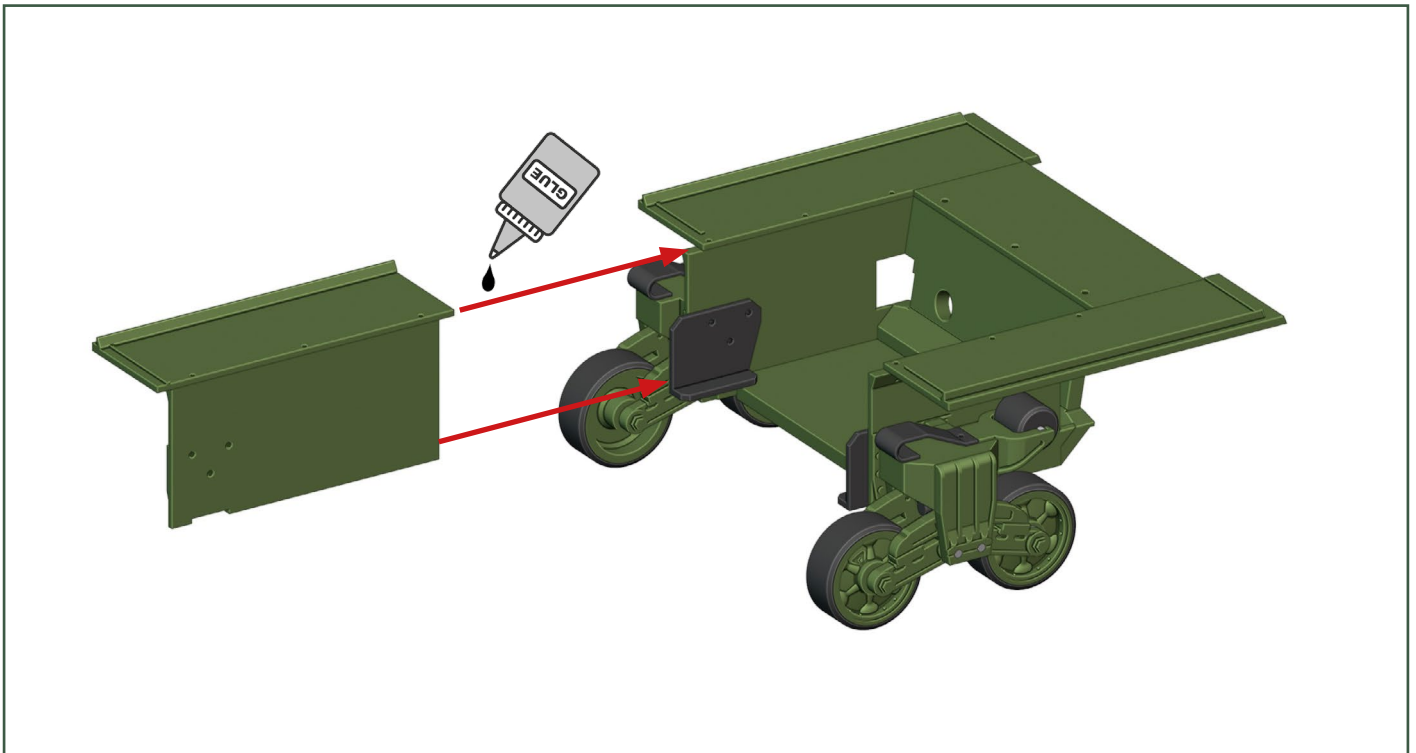

M4A3 Sherman - Build Guide

Hull:

M2 screw 10 mm

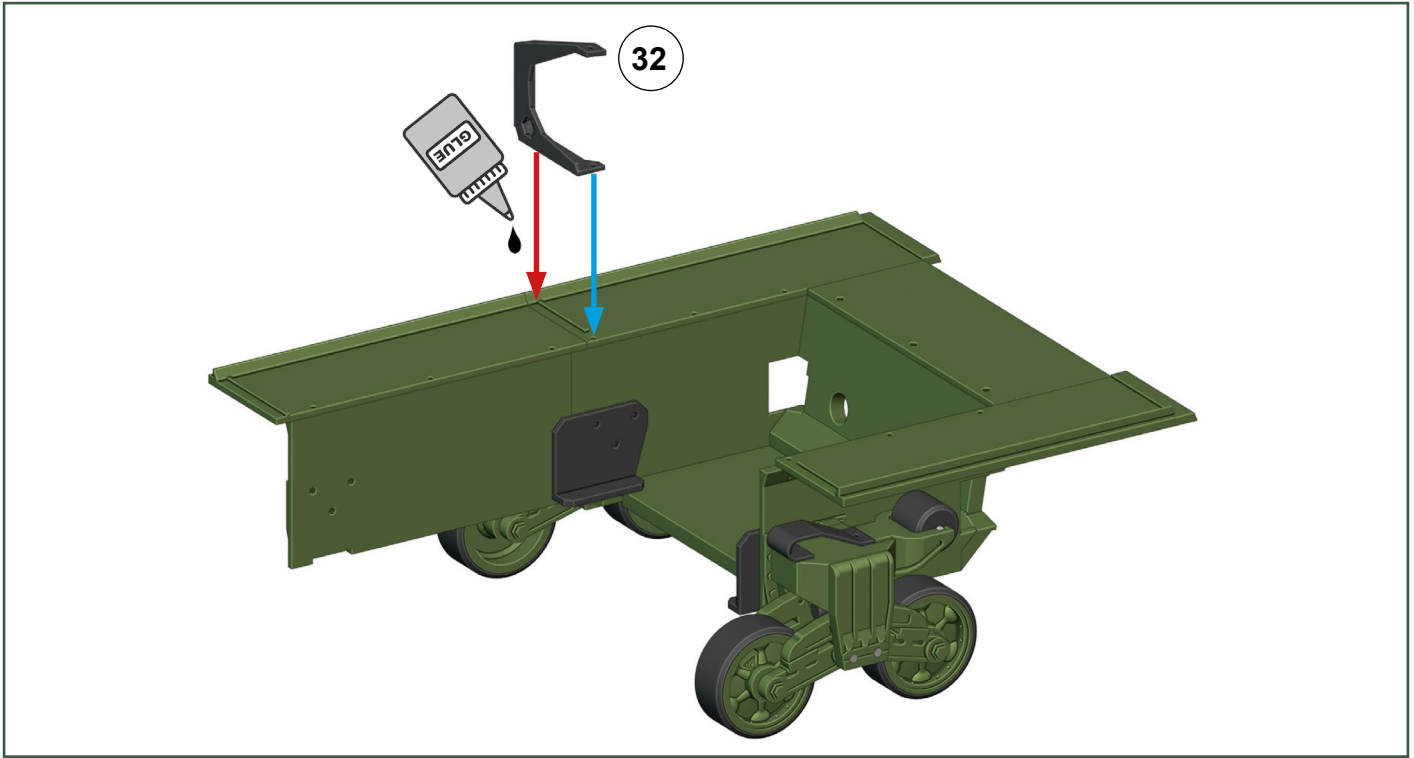

Hull:

3x M2 screw 8 mm

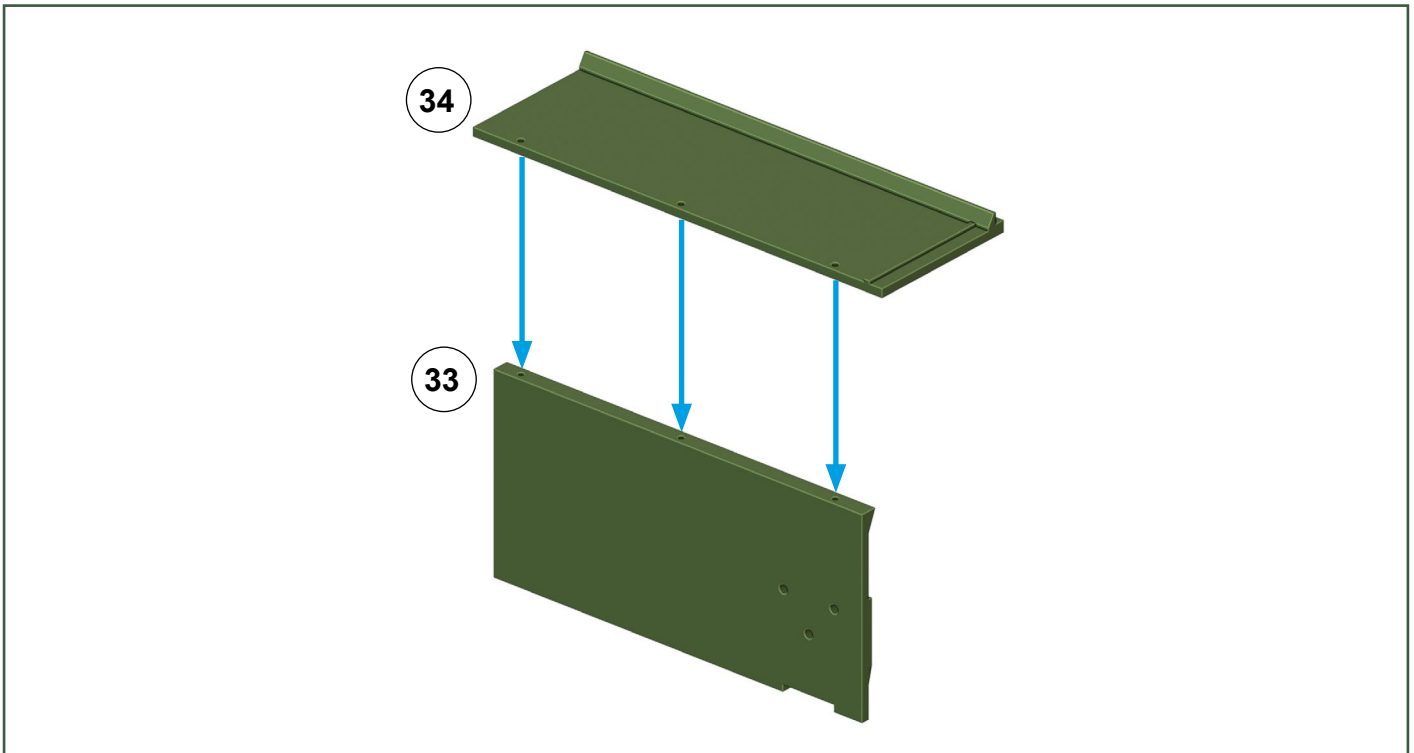

M4A3 Sherman - Build Guide

Hull:

M2 screw 10 mm

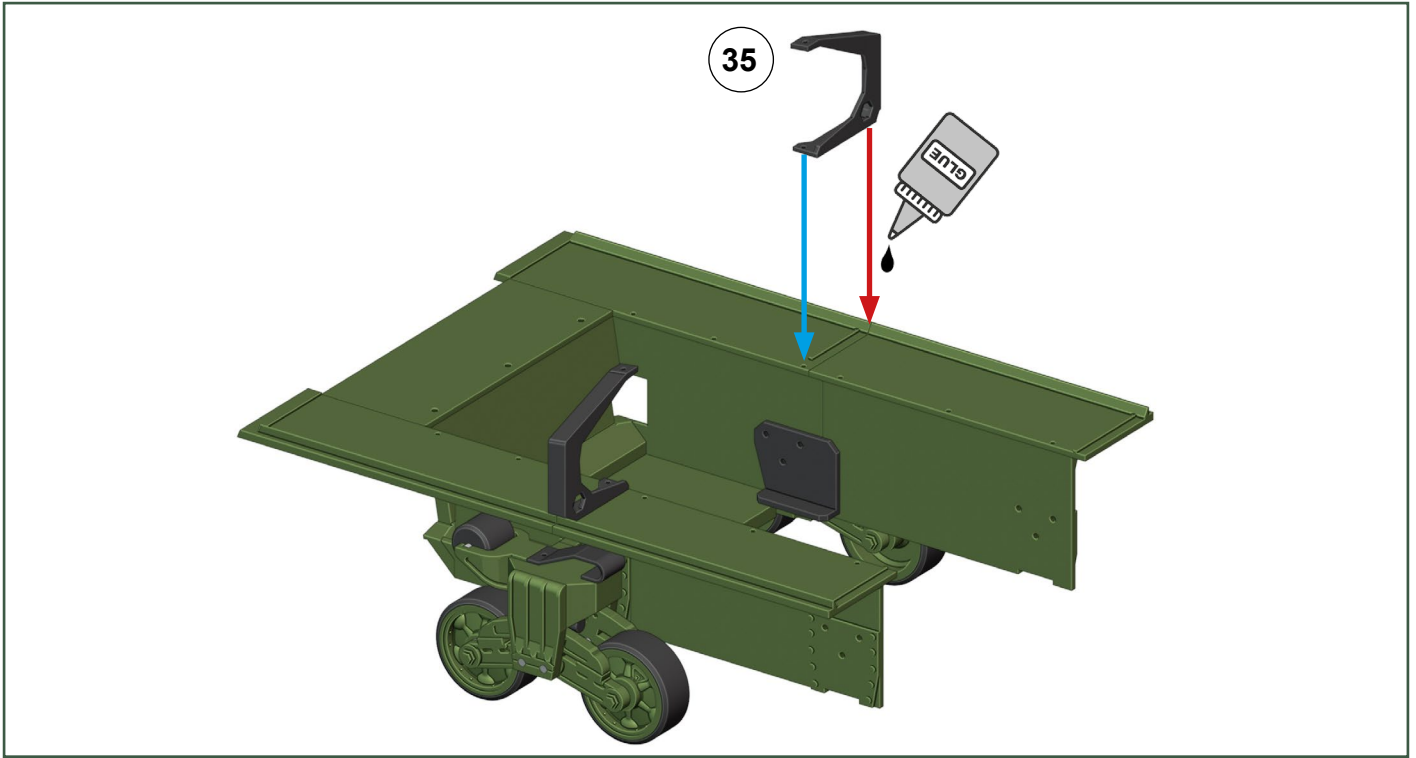

Hull:

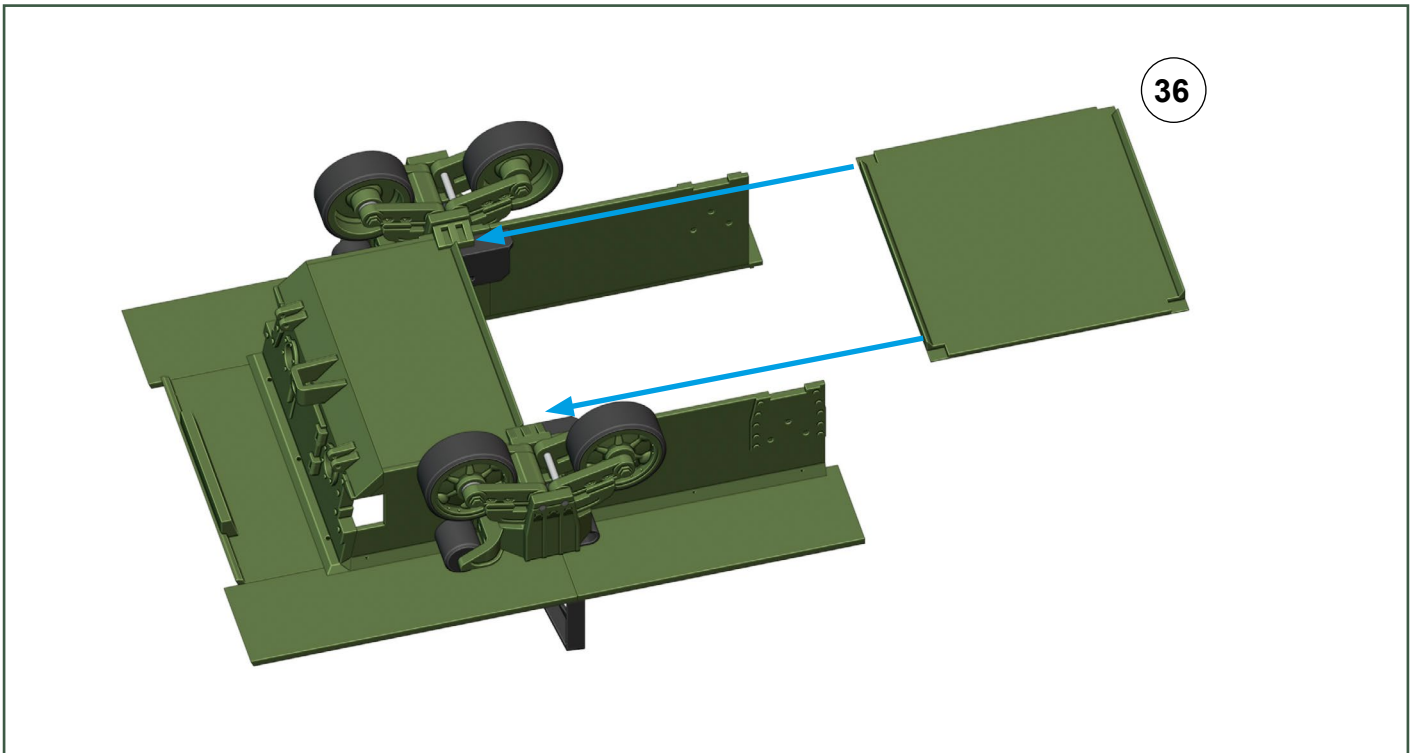

M4A3 Sherman - Build Guide

Hull:

left wheel block, 3x M3 screw 20 mm

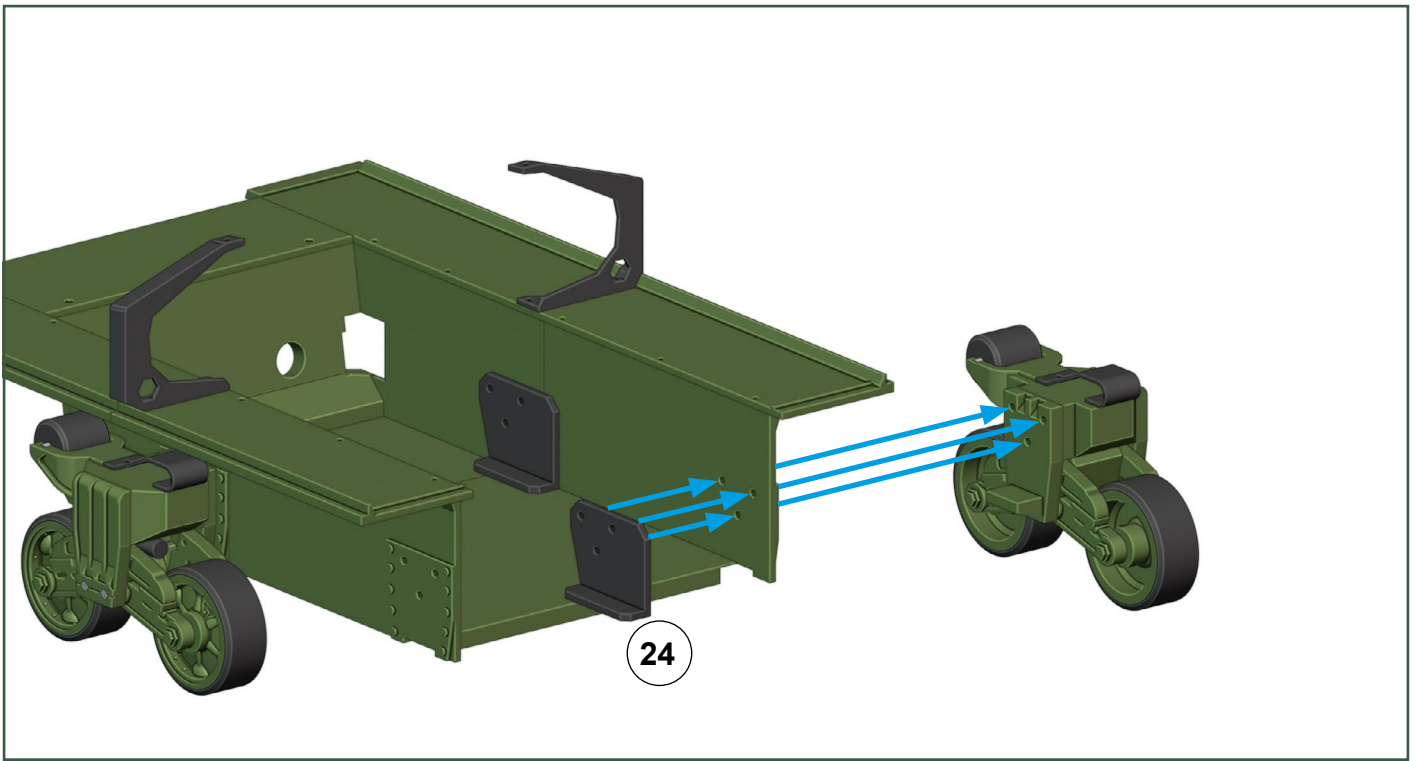

Hull:

right wheel block, 3x M3 screw 20 mm

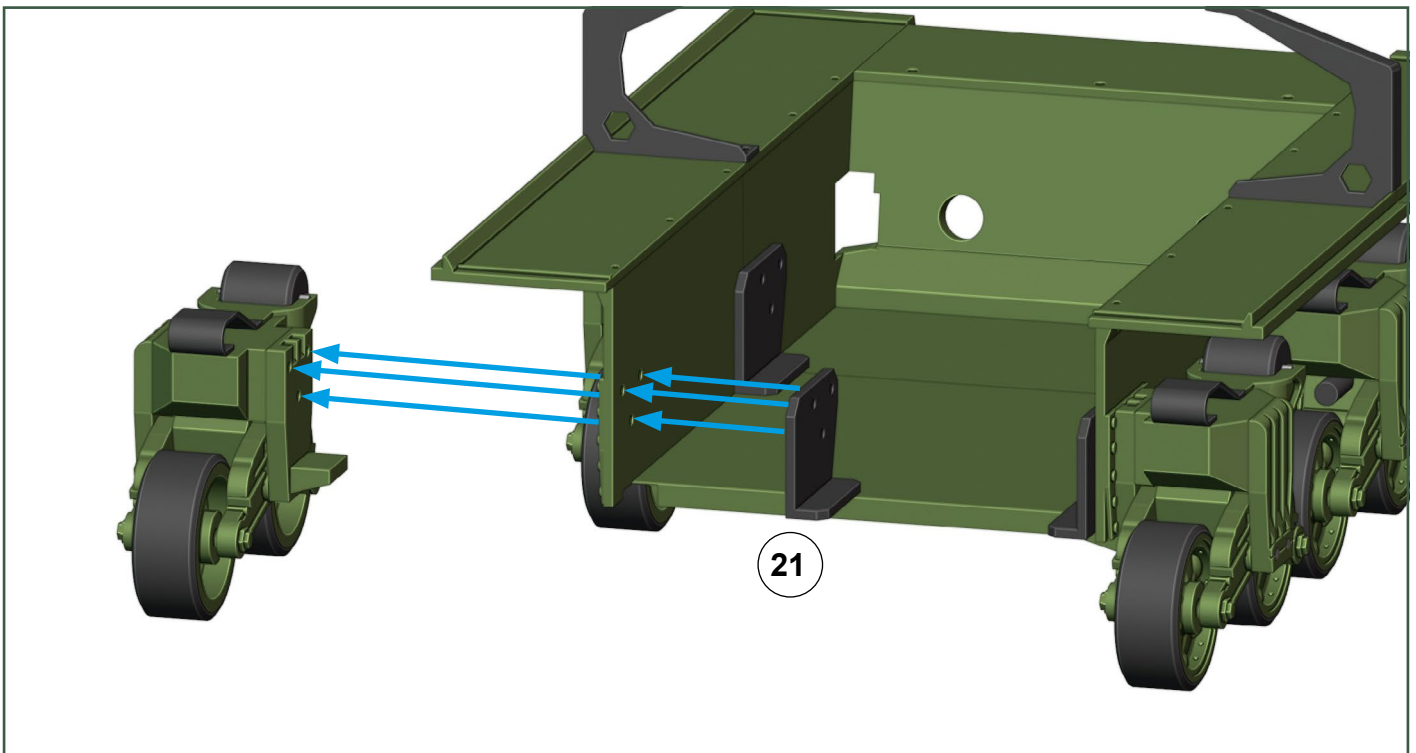

M4A3 Sherman – Build Guide

Hull:

2x M2 screw 8 mm

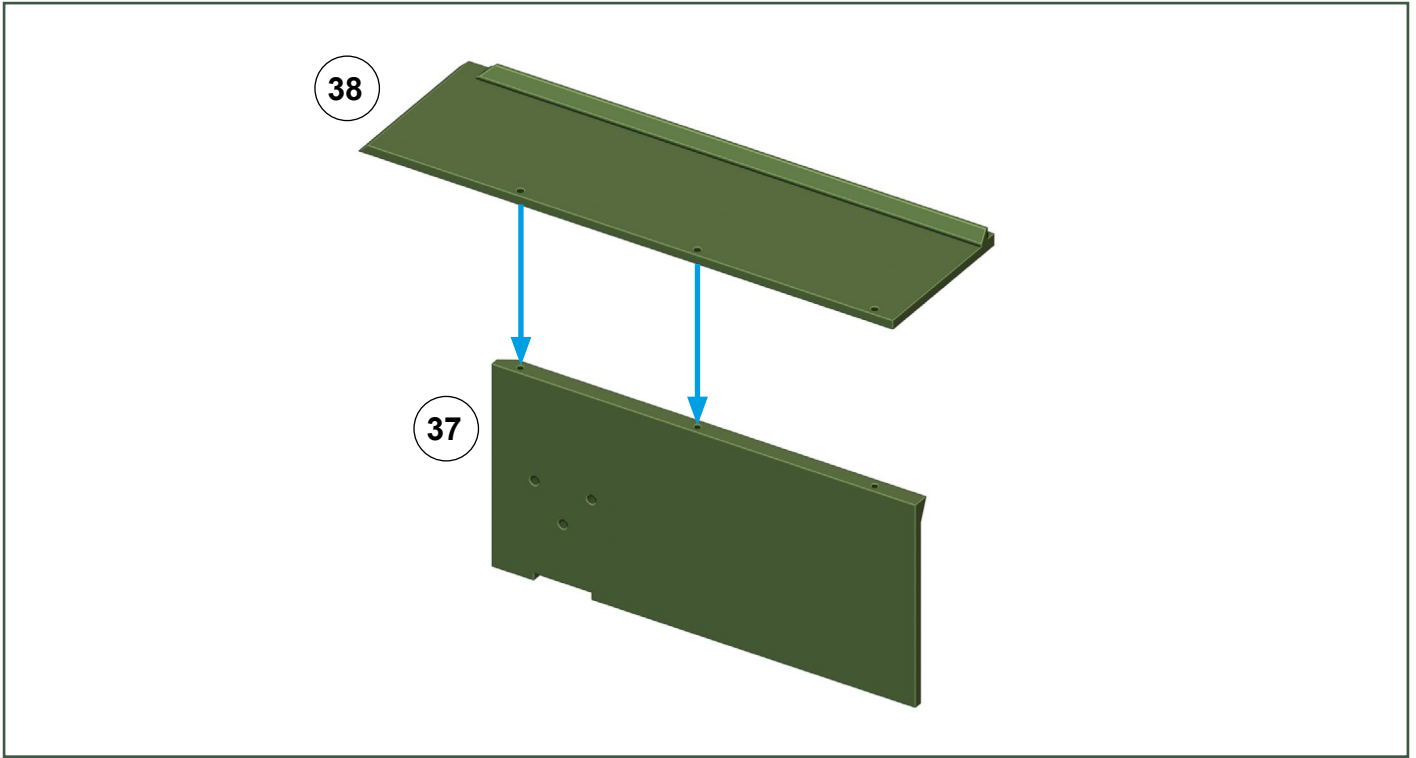

Hull:

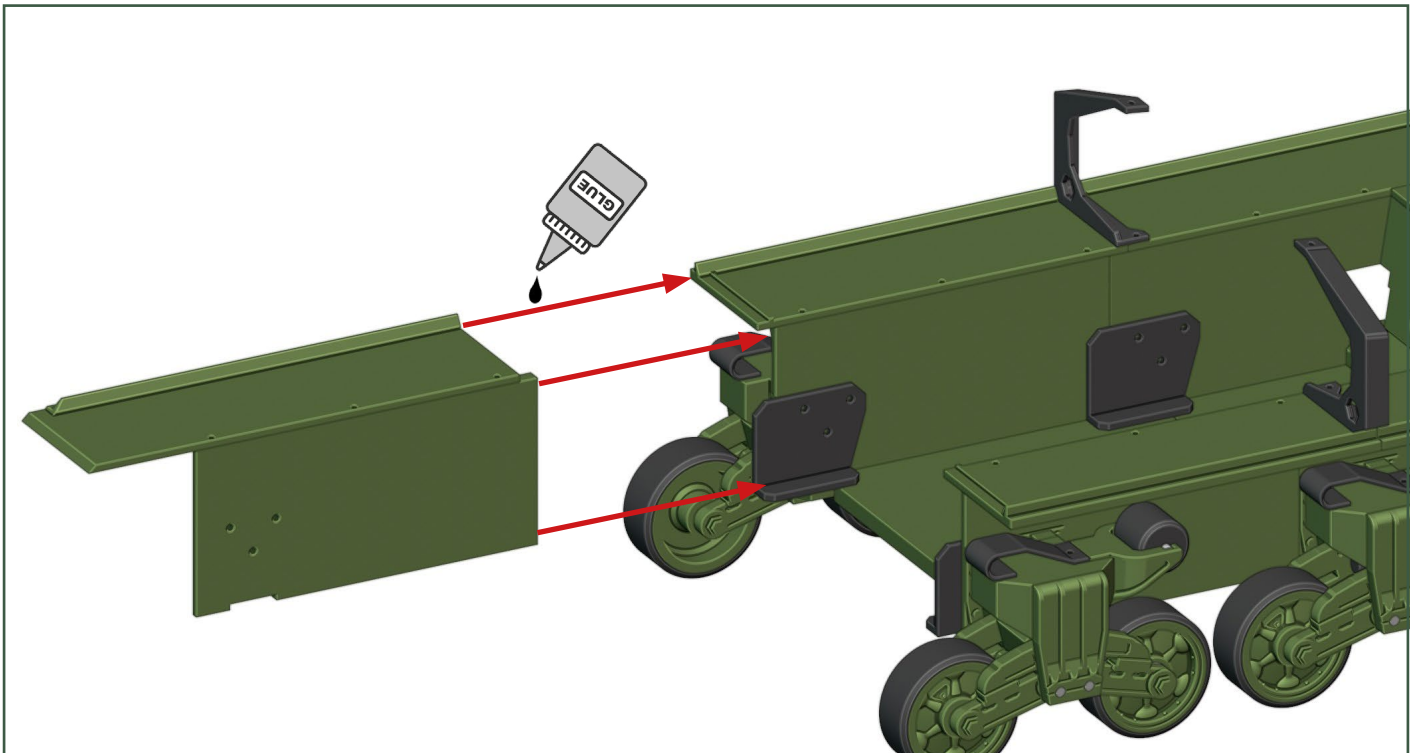

M4A3 Sherman - Build Guide

Hull:

M2 screw 10 mm

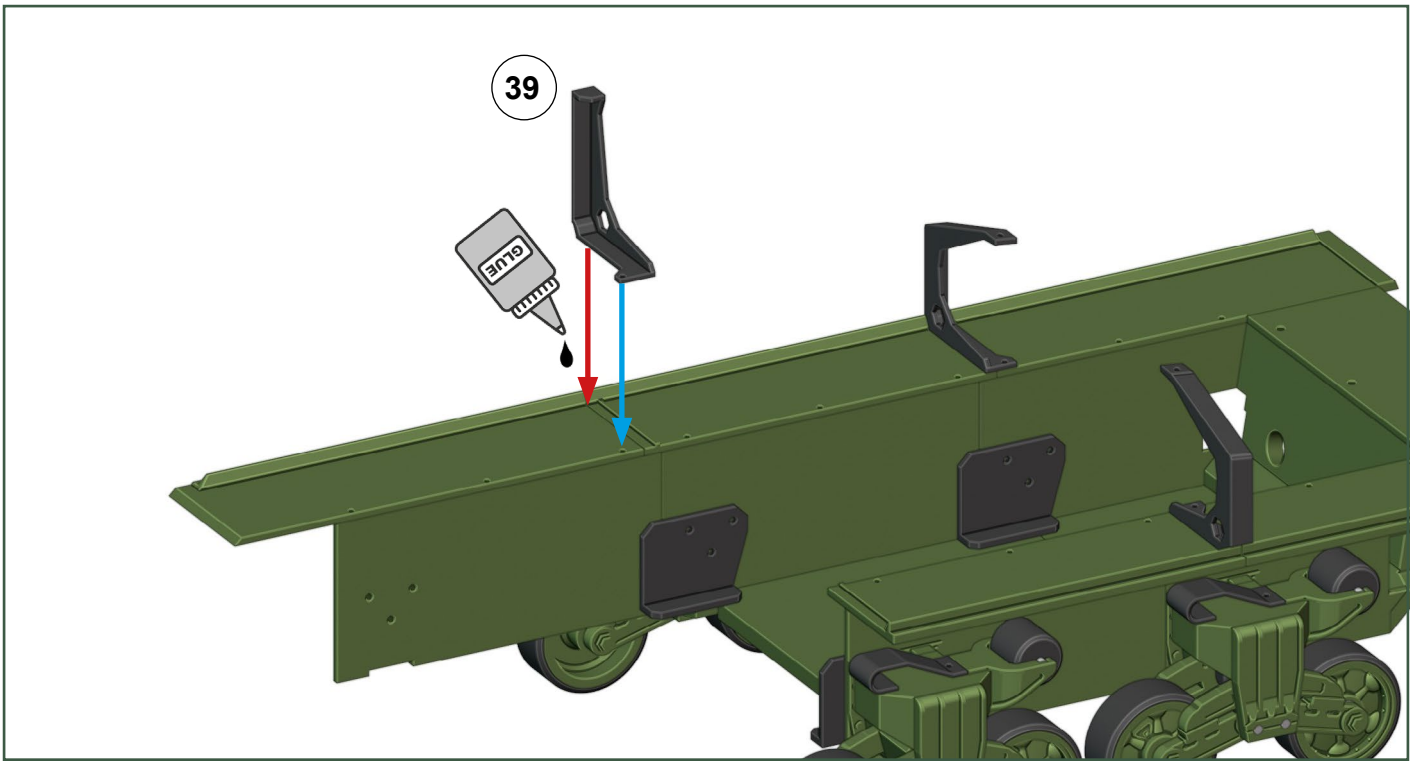

Hull:

2x M2 screw 8 mm

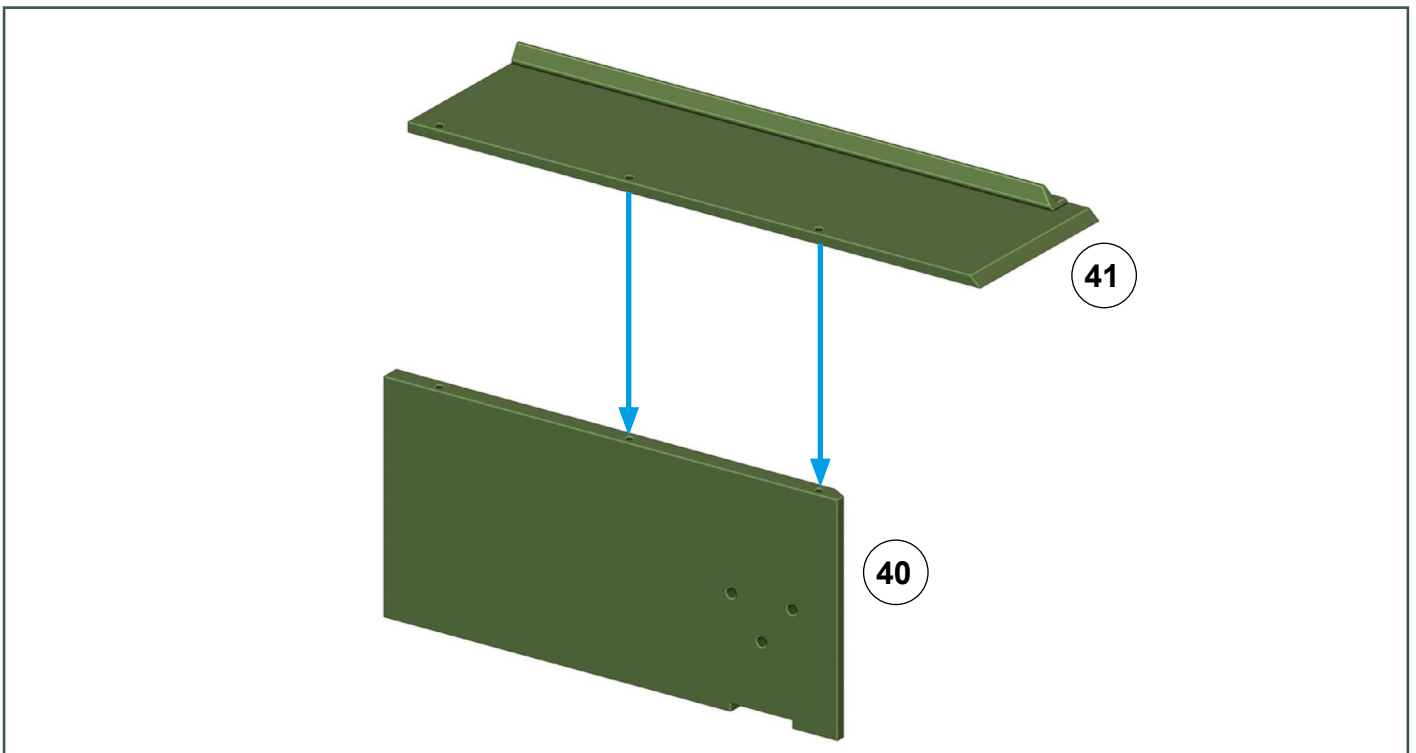

M4A3 Sherman - Build Guide

-  use glue
-  do not glue

Hull:

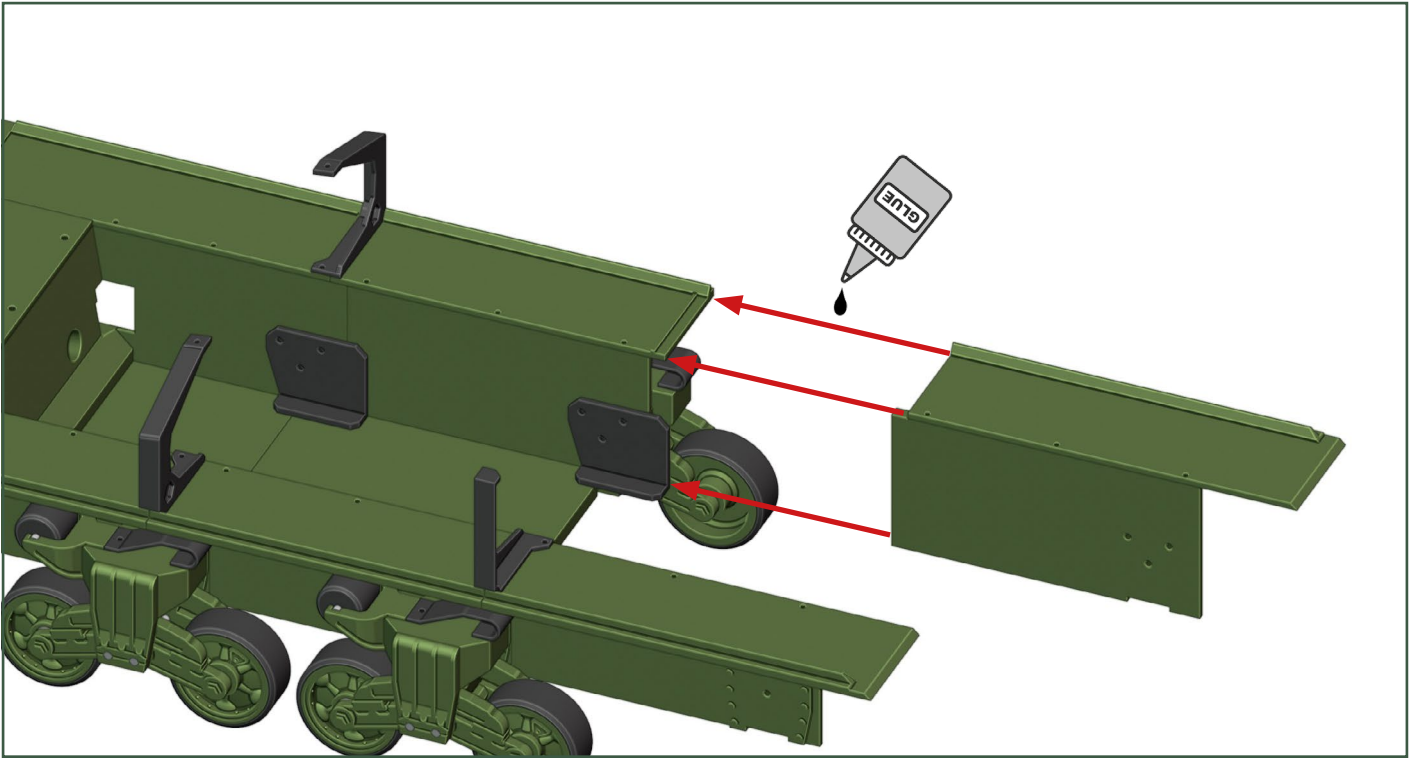

Hull:

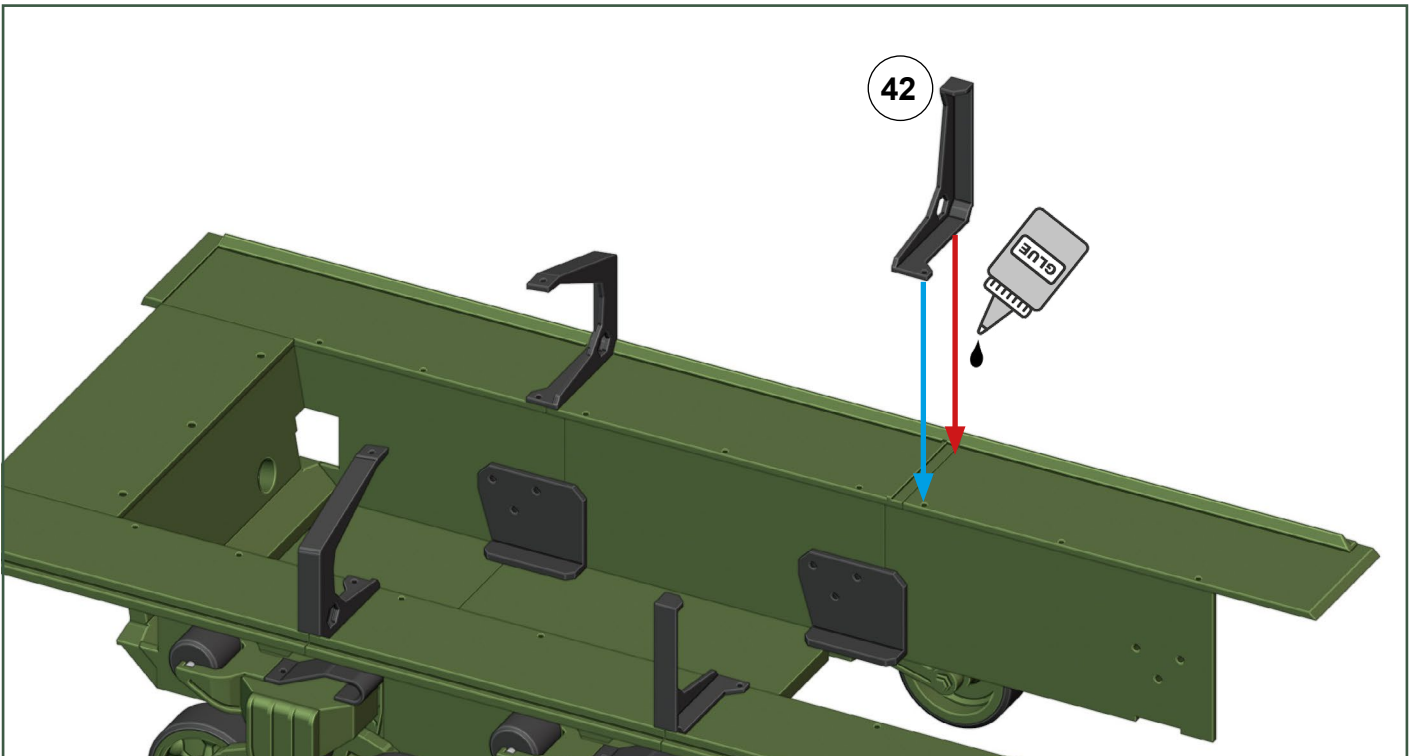

M4A3 Sherman - Build Guide

Hull:

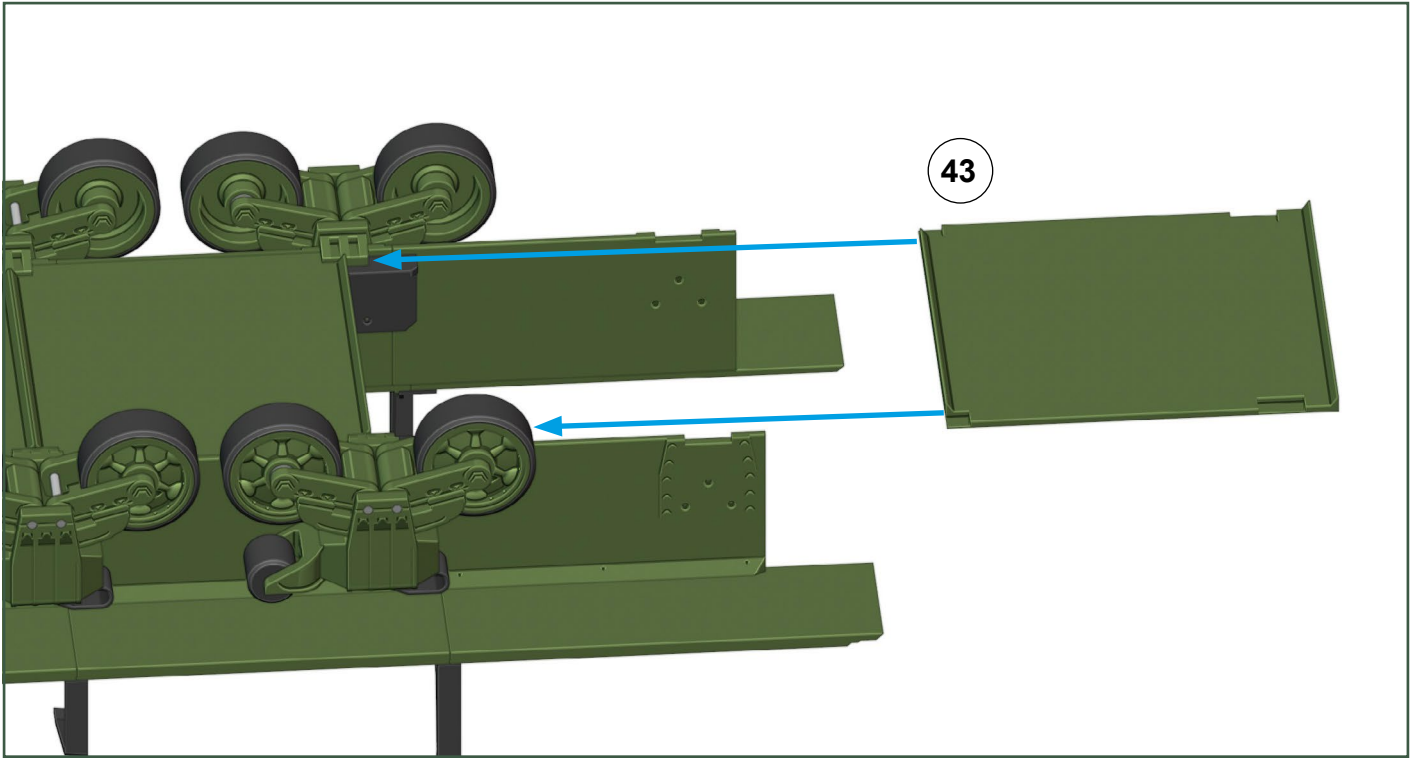

Hull:

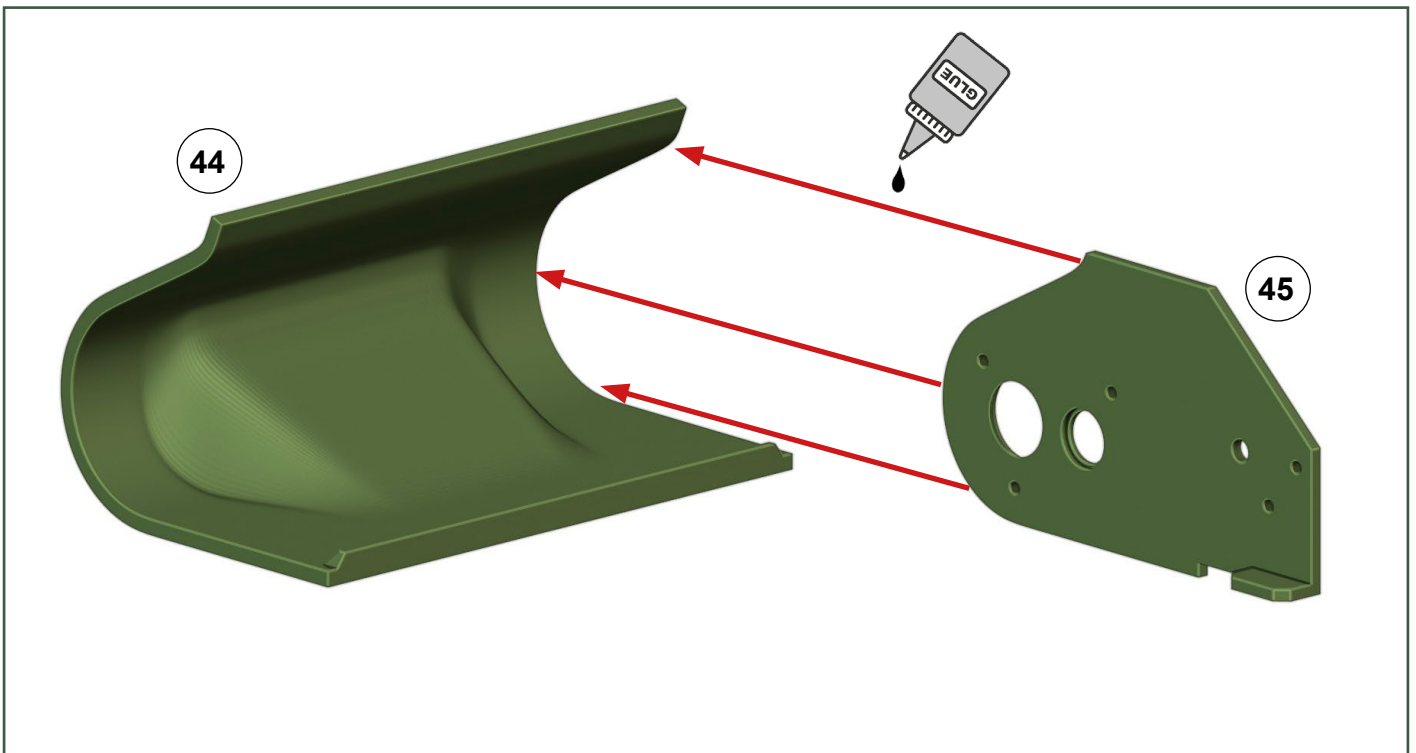

M4A3 Sherman - Build Guide

Hull:

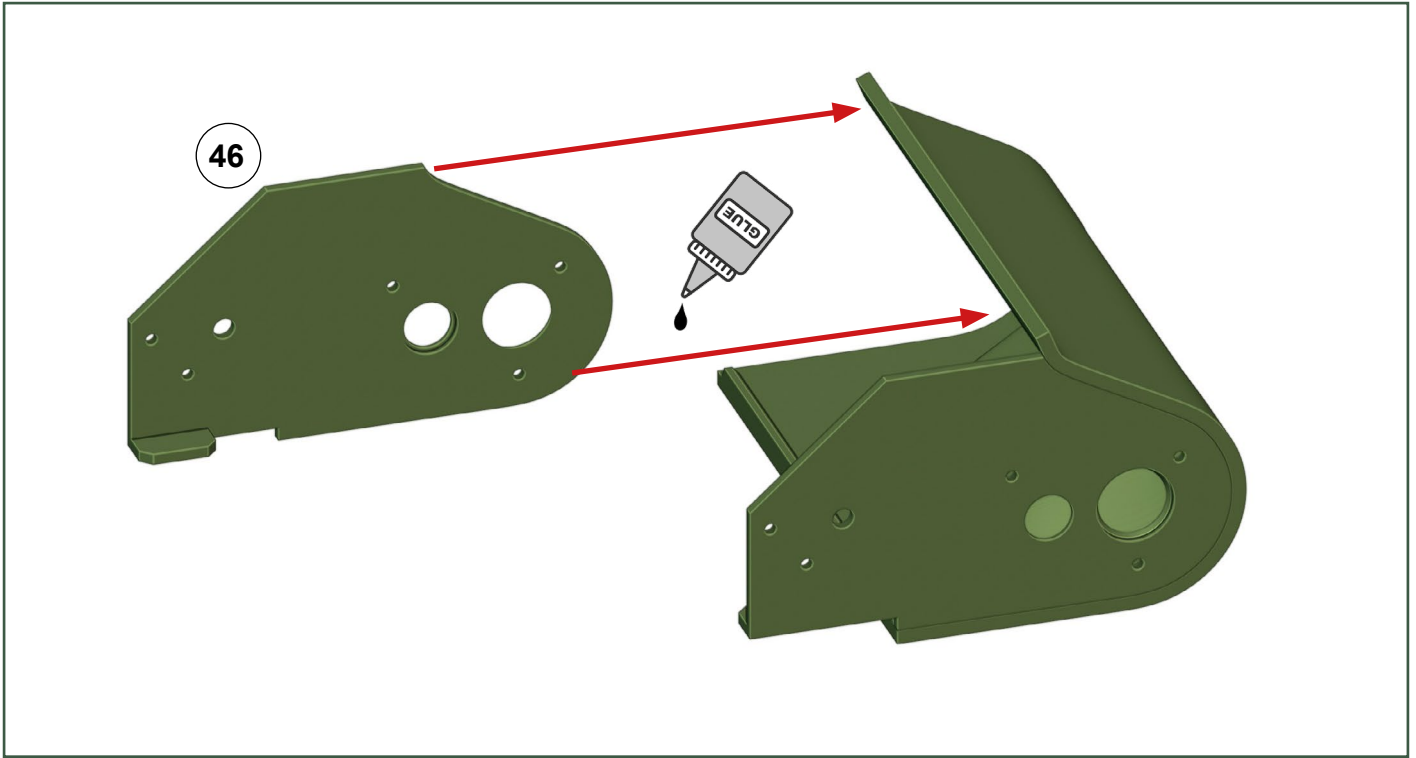

Hull:

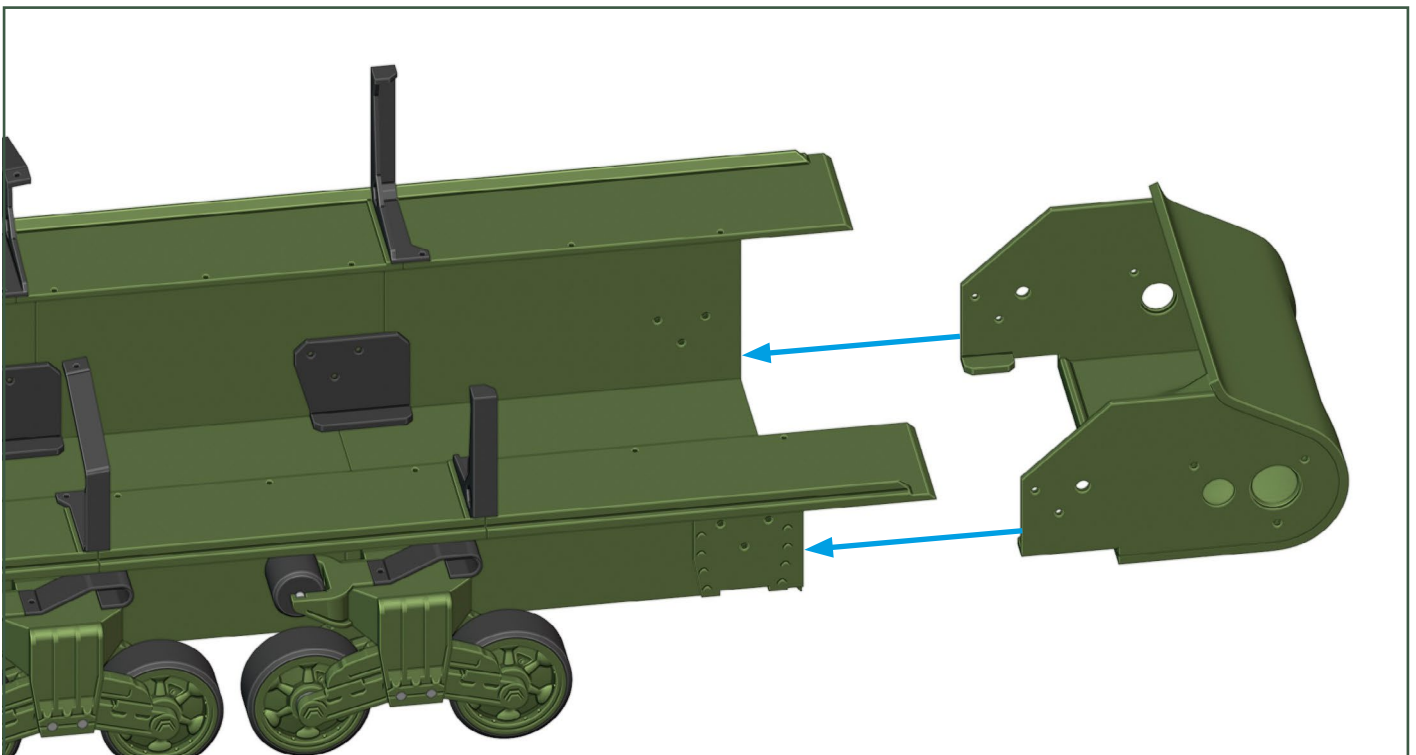

M4A3 Sherman - Build Guide

Hull:

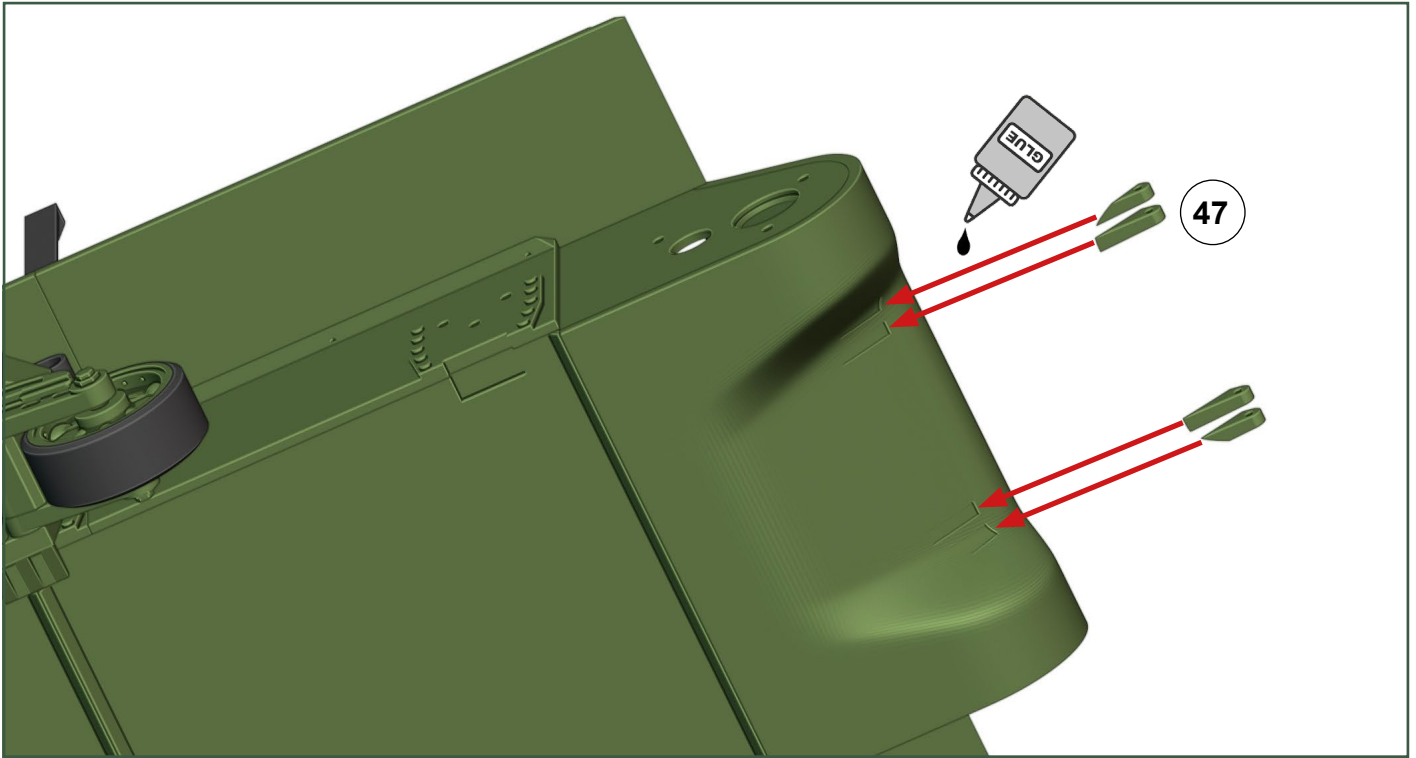

Hull:

right wheel block, 3x M3 screw 20 mm

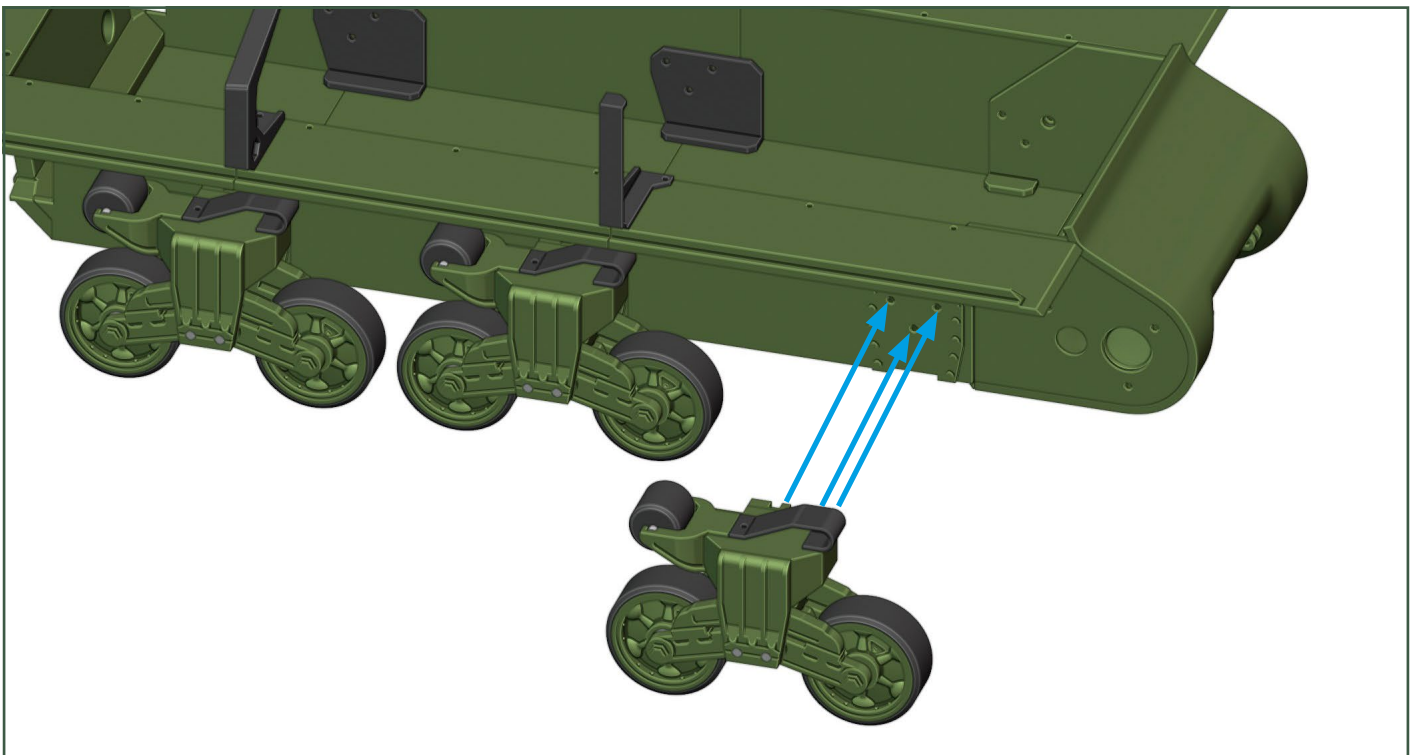

M4A3 Sherman - Build Guide

Hull:

left wheel block, 3x M3 screw 20 mm

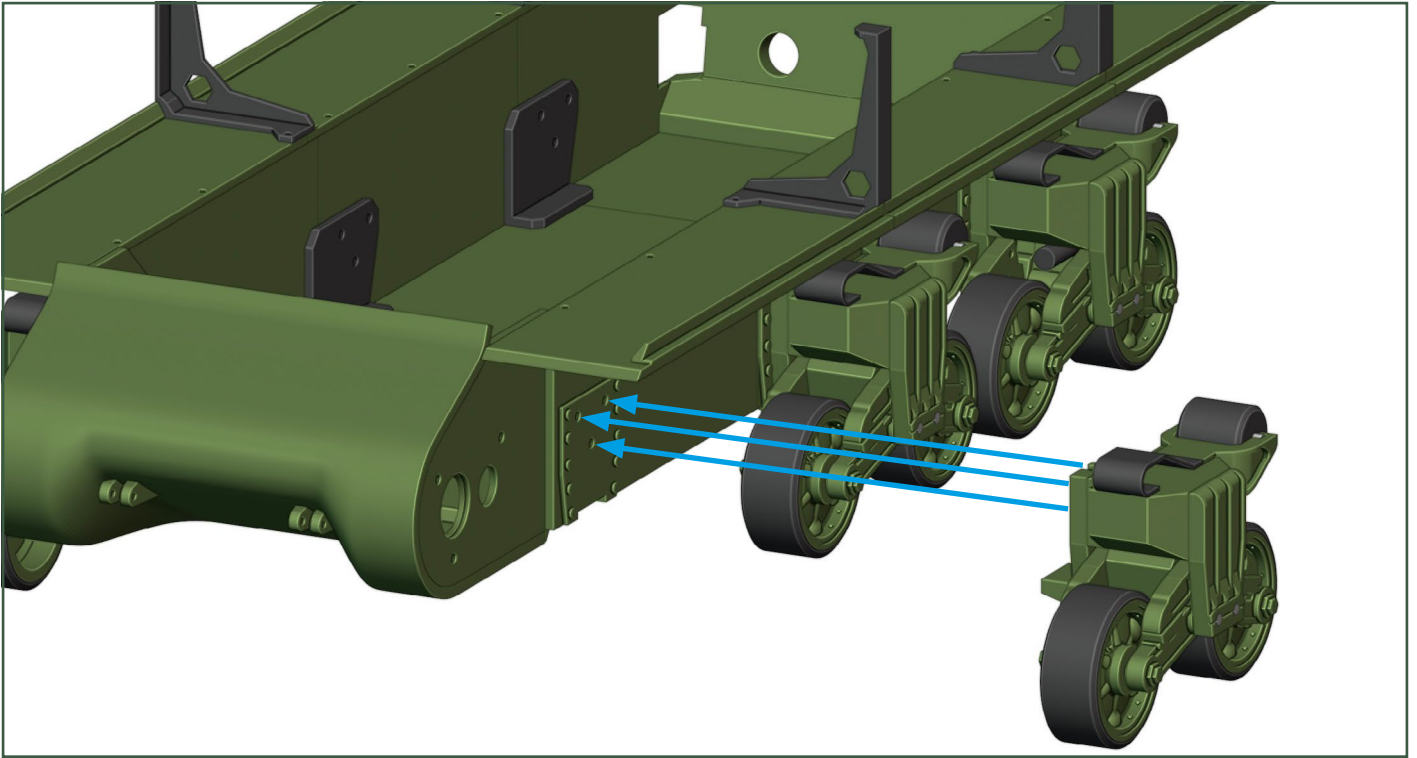

Hull:

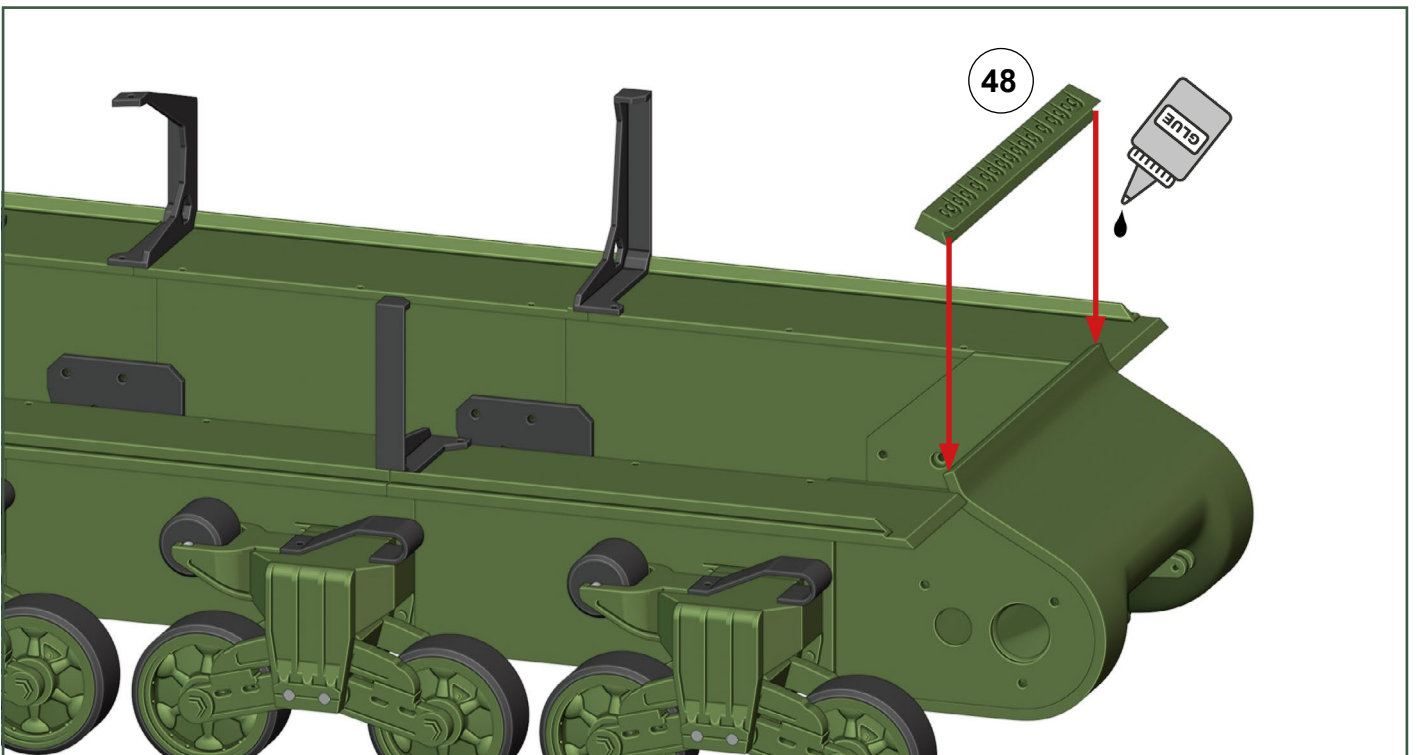

M4A3 Sherman - Build Guide

Hull:

remove support on parts 49 and 50

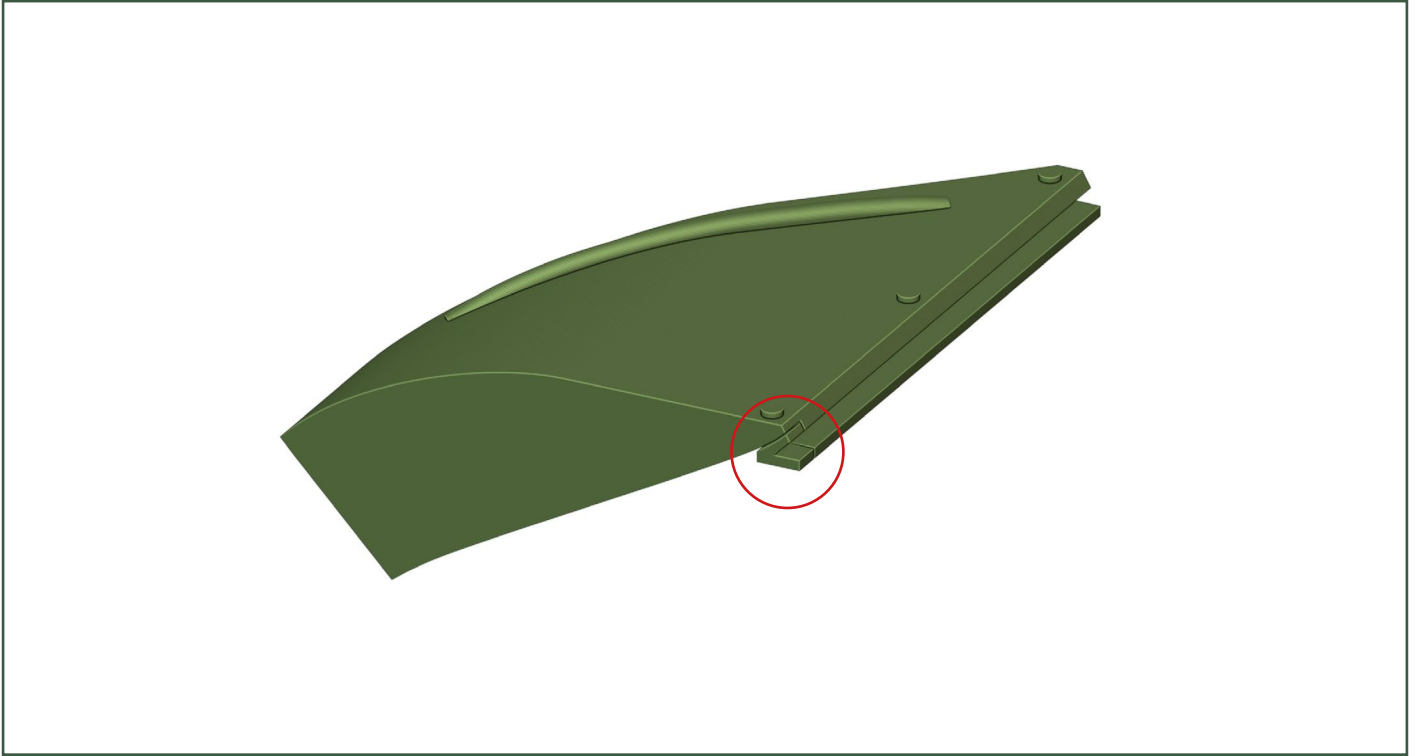

Hull:

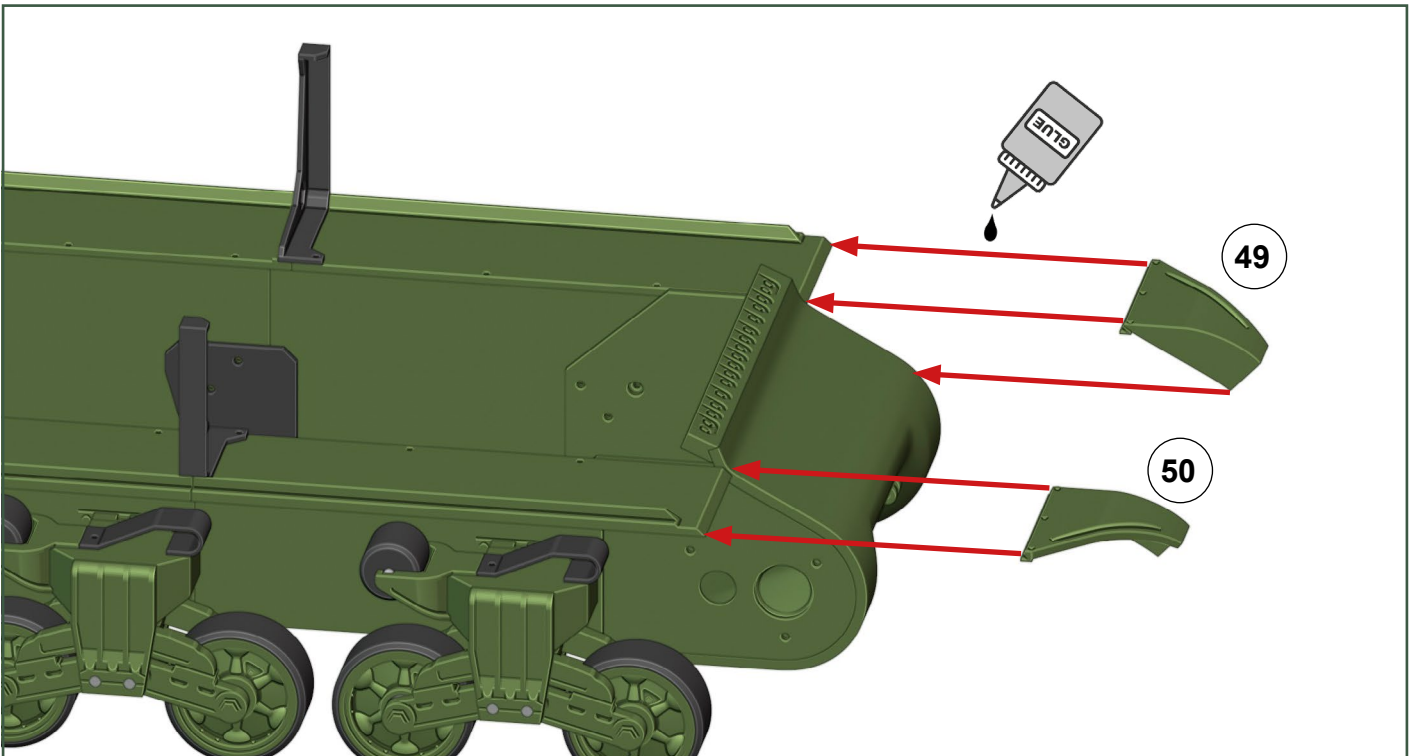

M4A3 Sherman – Build Guide

Hull:

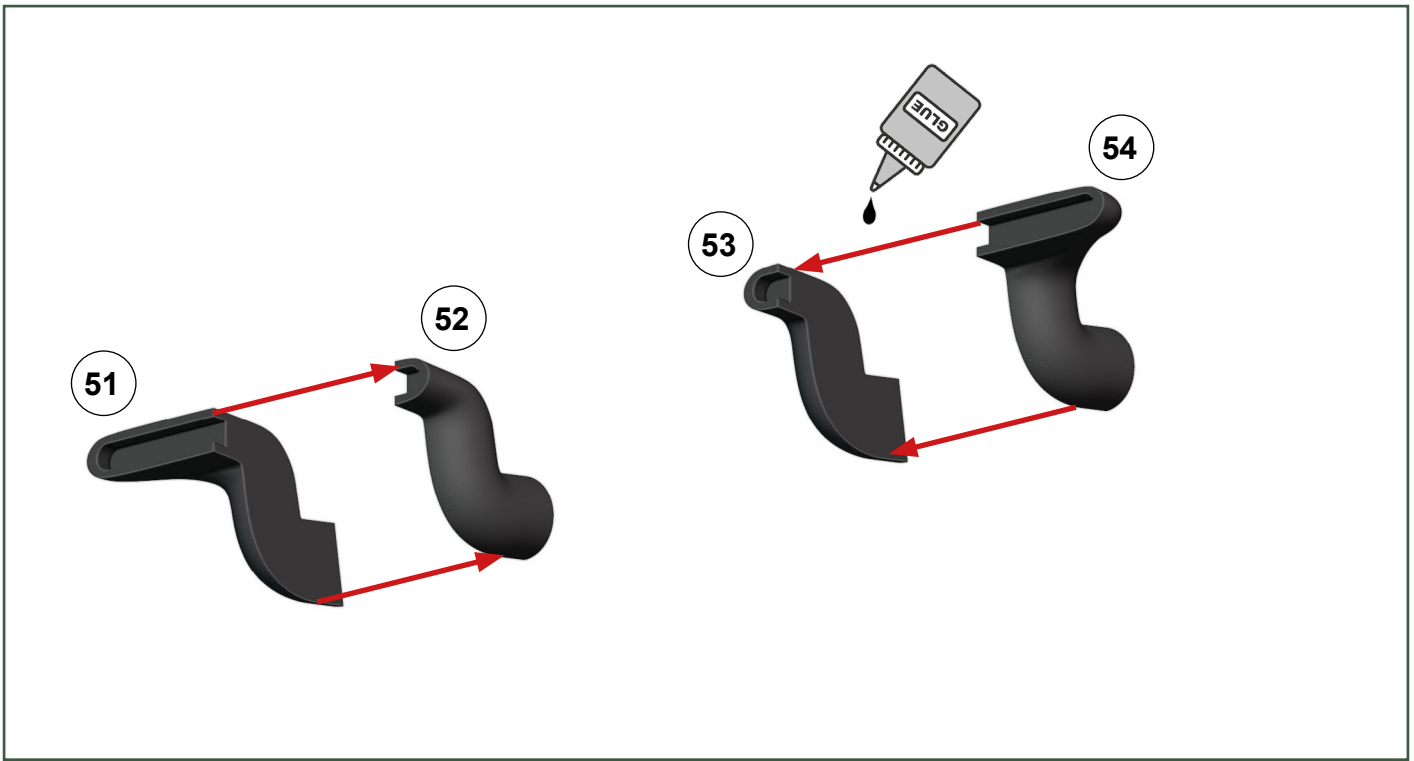

Hull:

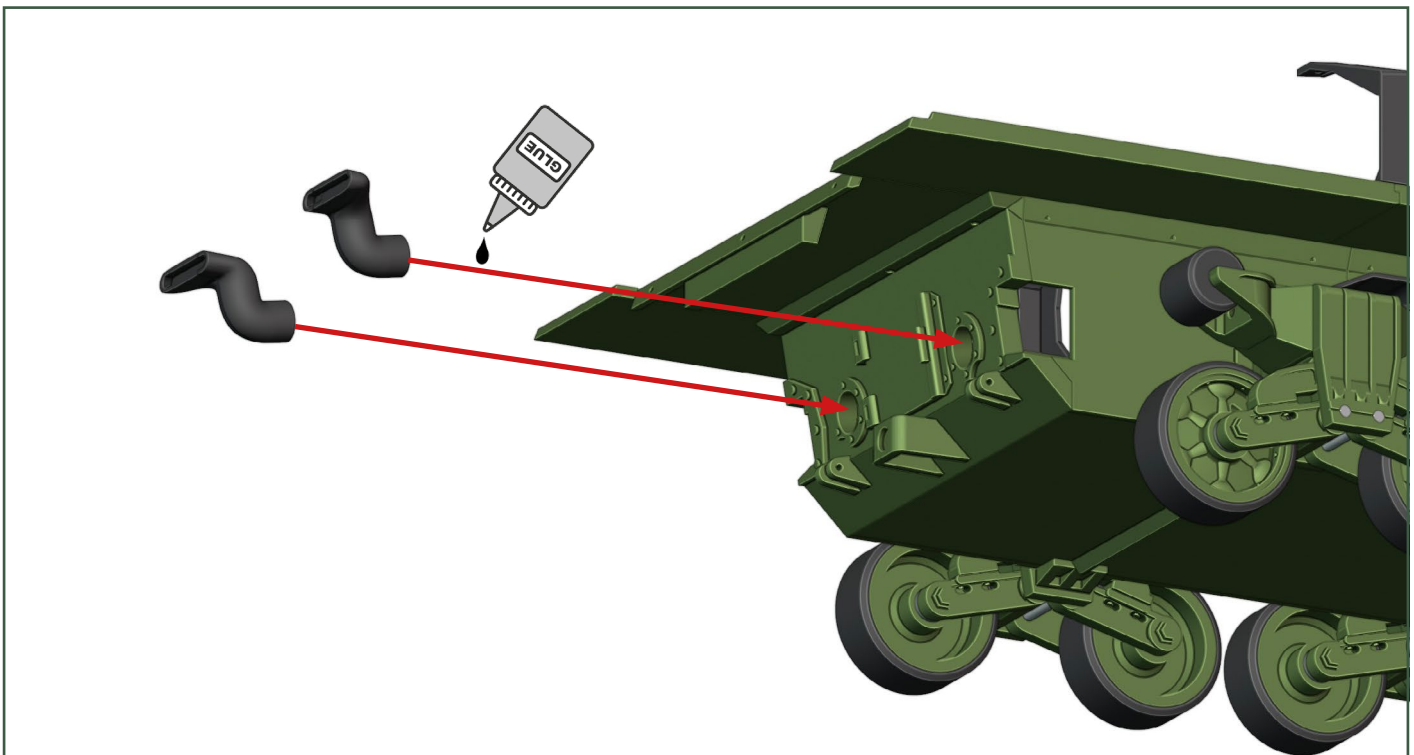

M4A3 Sherman - Build Guide

Hull:

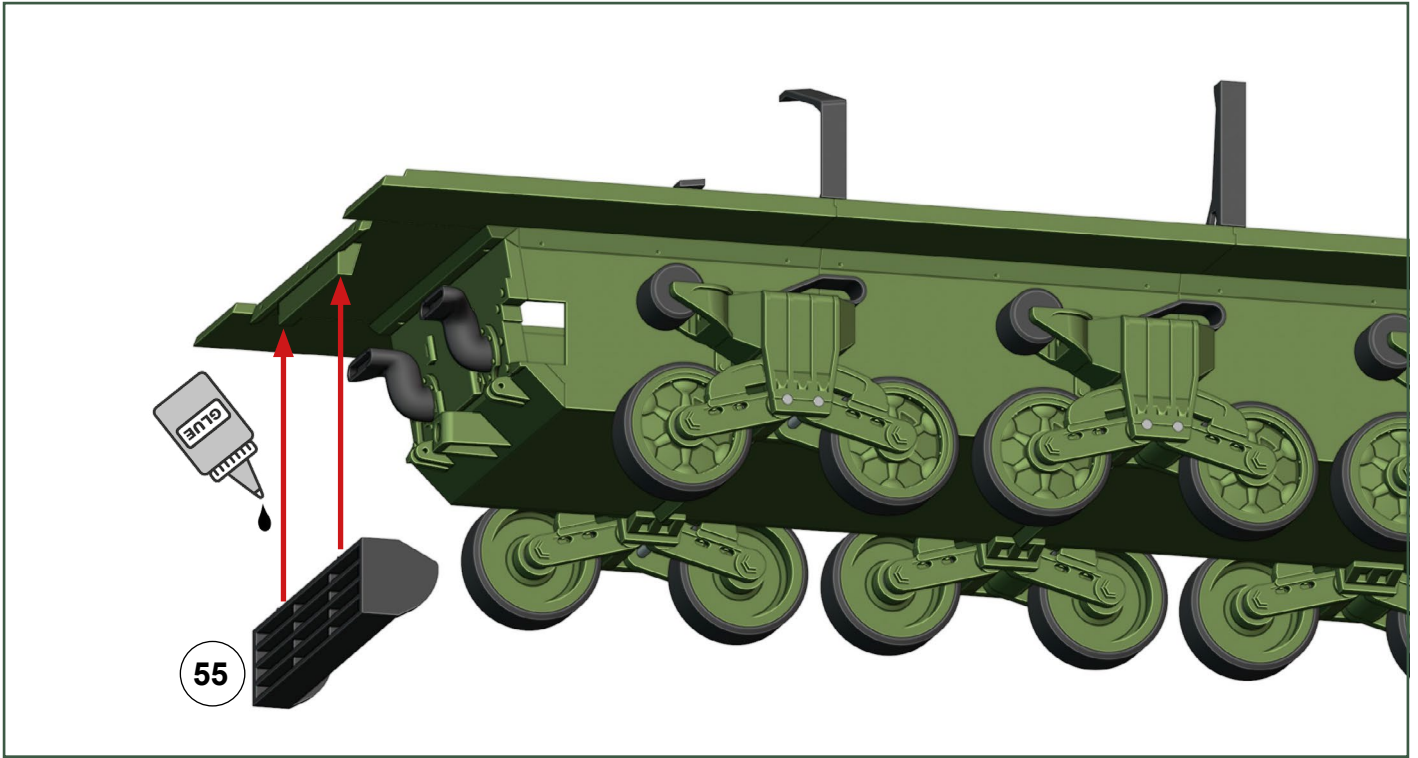

Gearboxes:

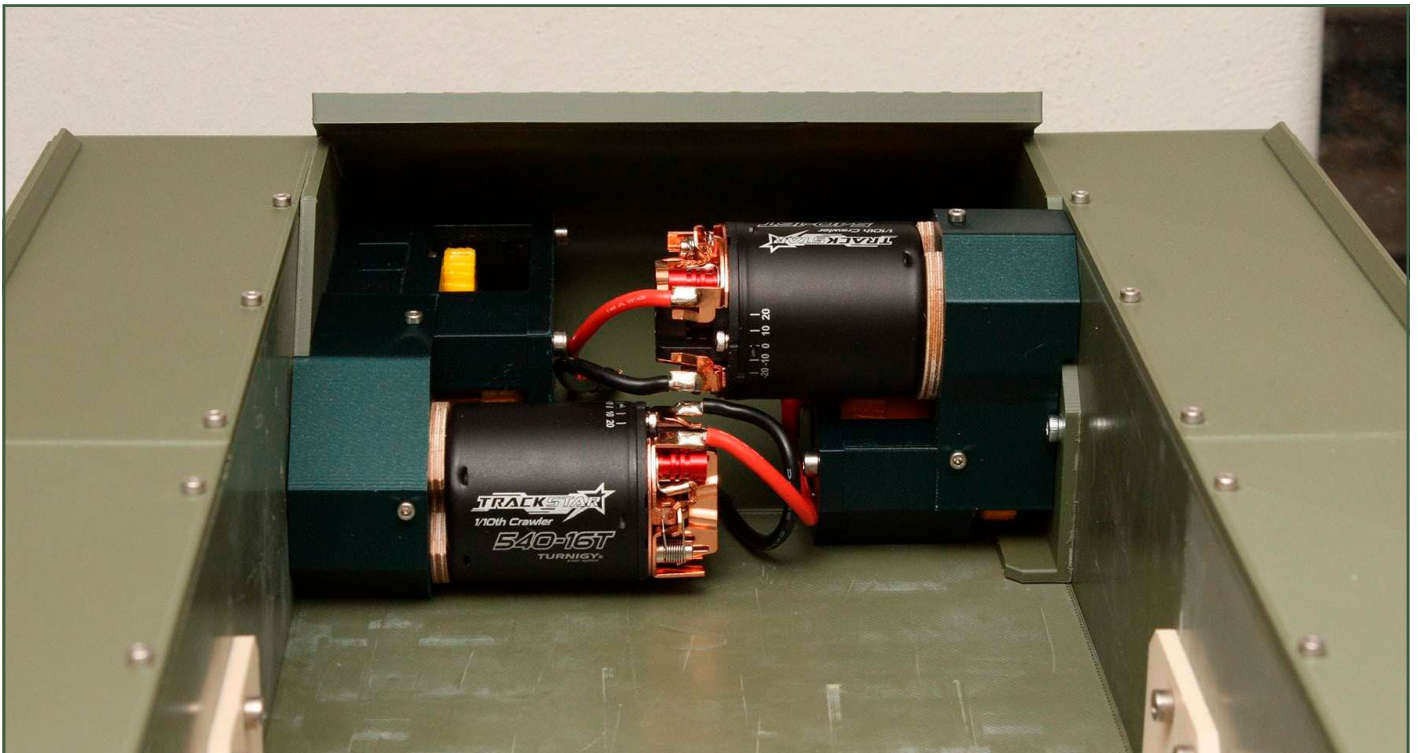

M4A3 Sherman – Build Guide

Gearbox left:

ball bearing 10x15x4 and 15x21x4

← use glue

← do not glue

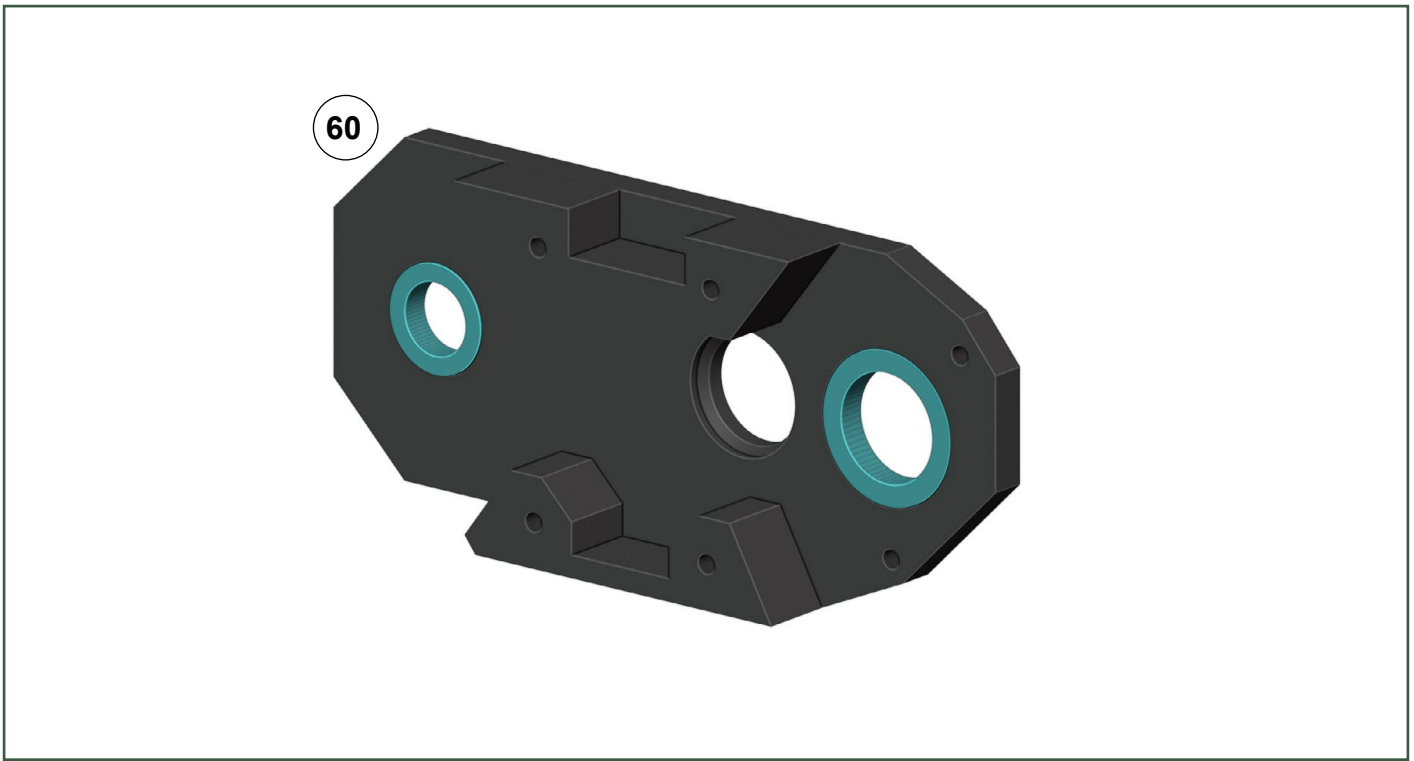

Gearbox left:

you can mount parts 61 and 62 together using small amount of glue if needed

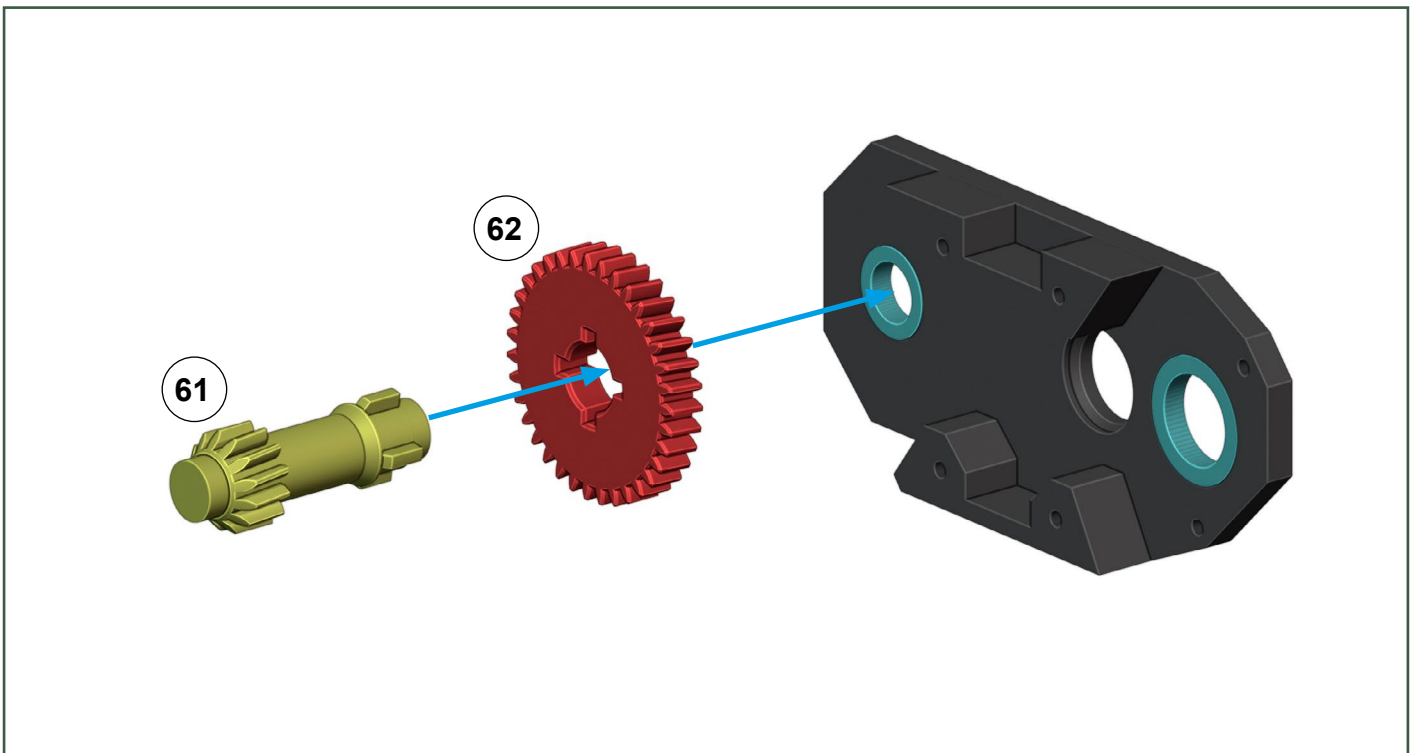

M4A3 Sherman - Build Guide

Gearbox left:

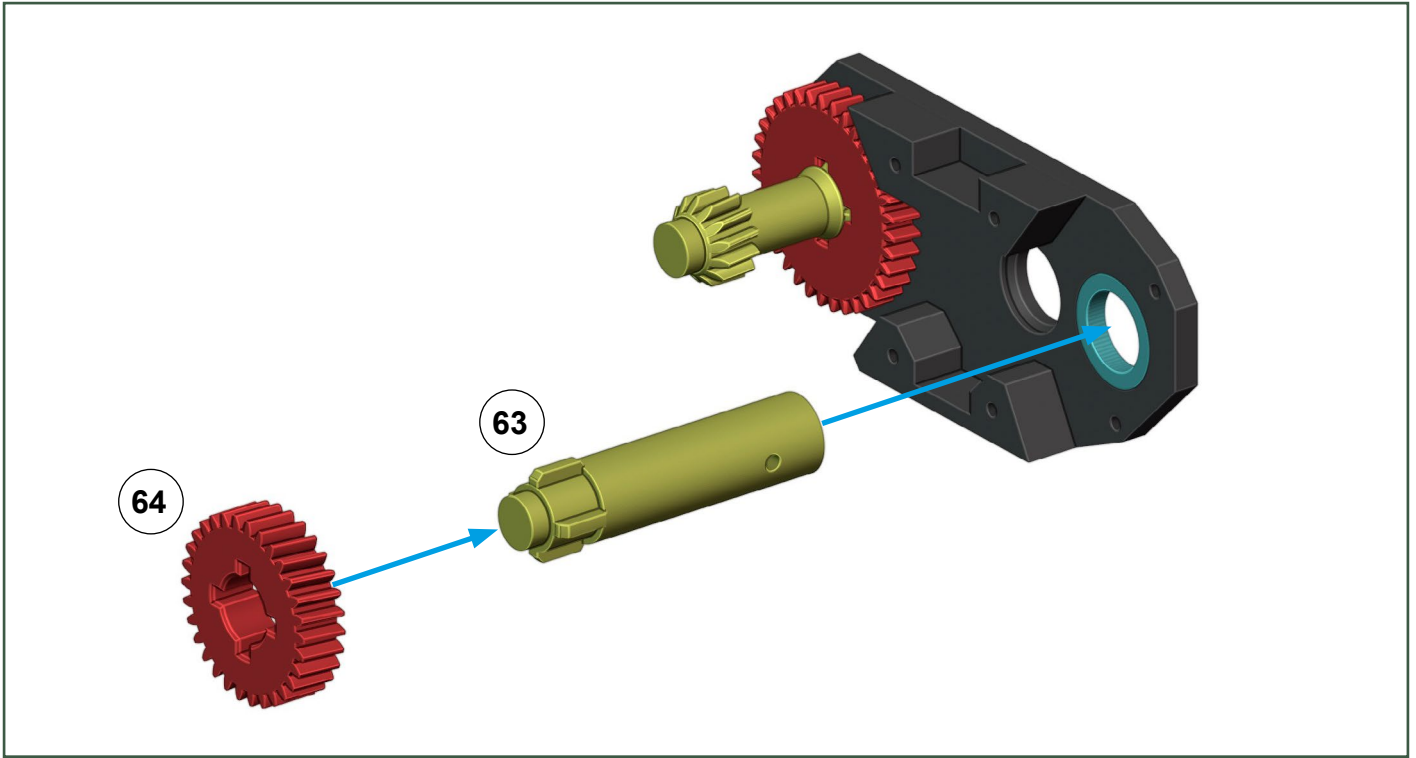

Gearbox left:

2x ball bearing 10x15x4

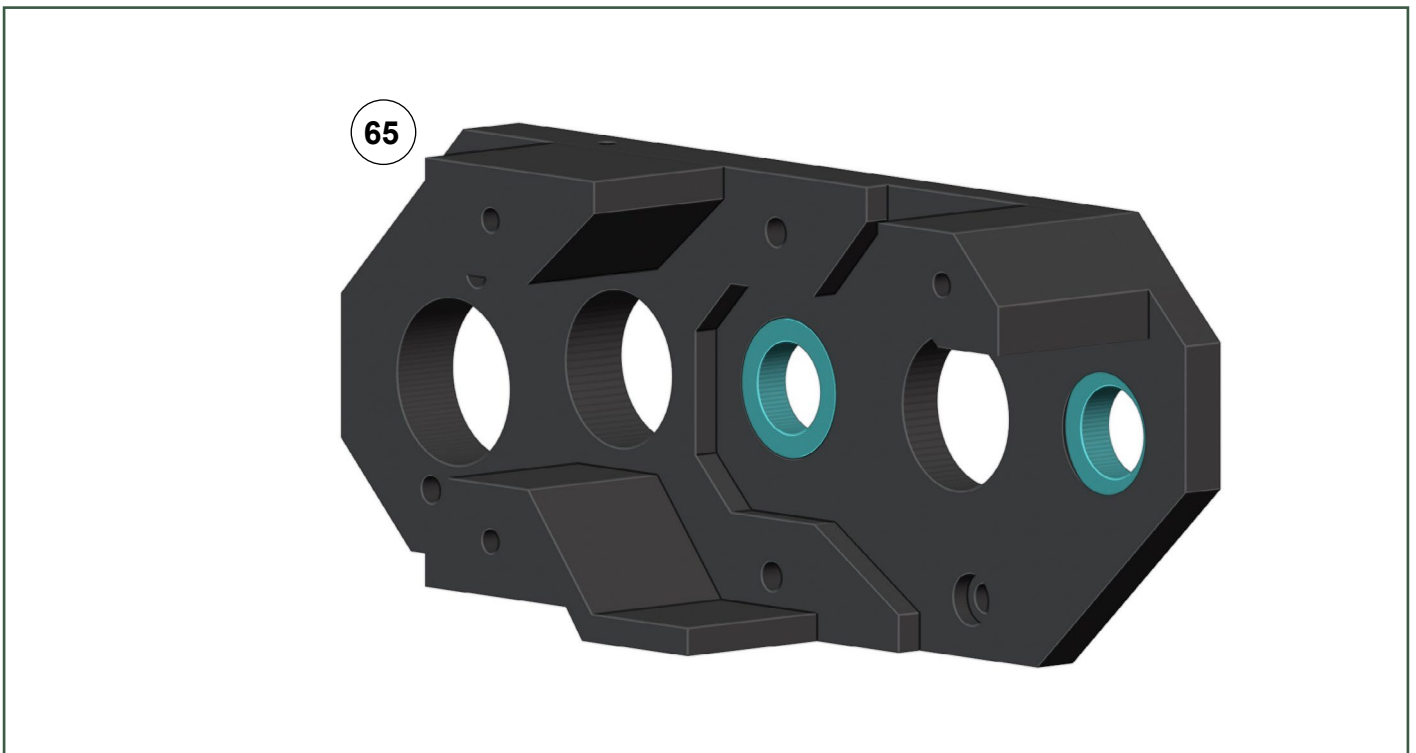

M4A3 Sherman - Build Guide

Gearbox left:

2x M3 screw 10 mm, 2x M3 screw 12 mm

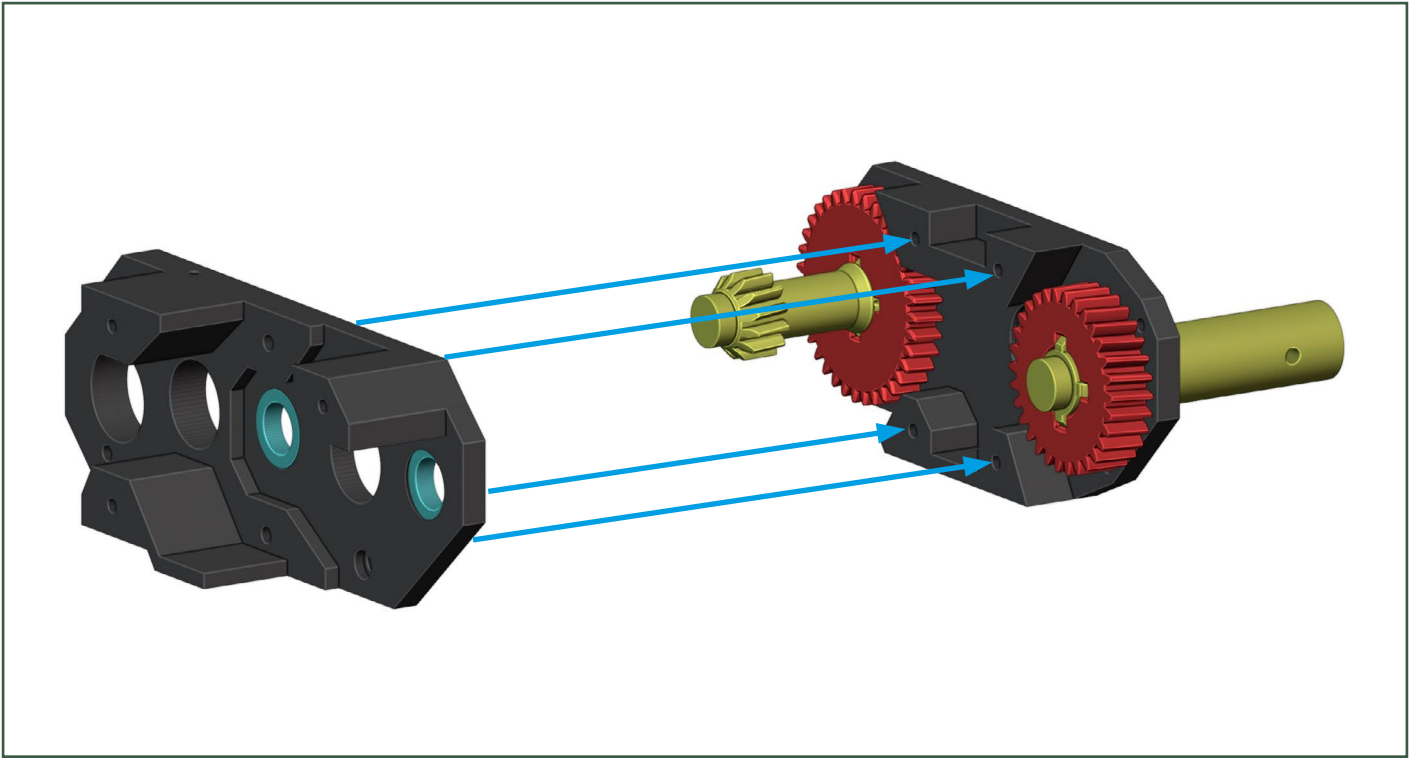

Gearbox left:

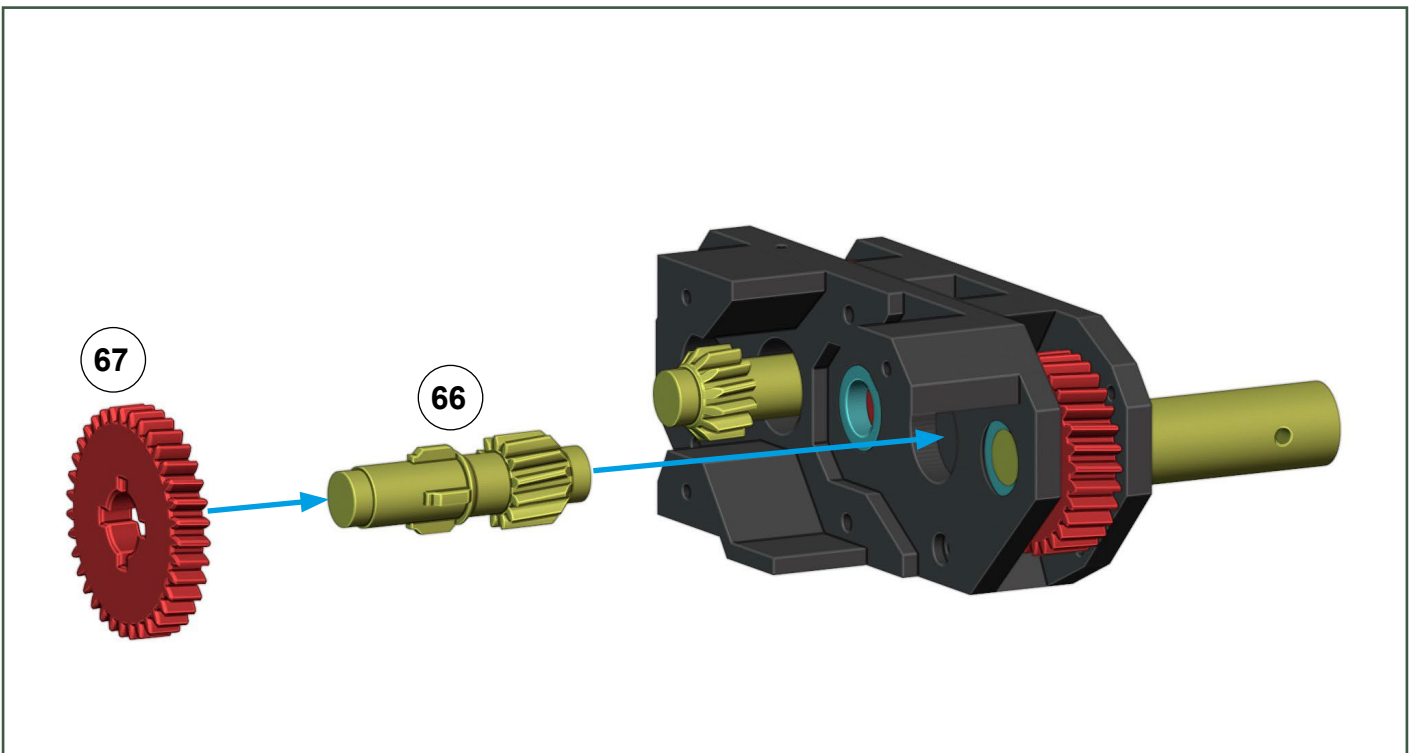

M4A3 Sherman - Build Guide

Gearbox left:

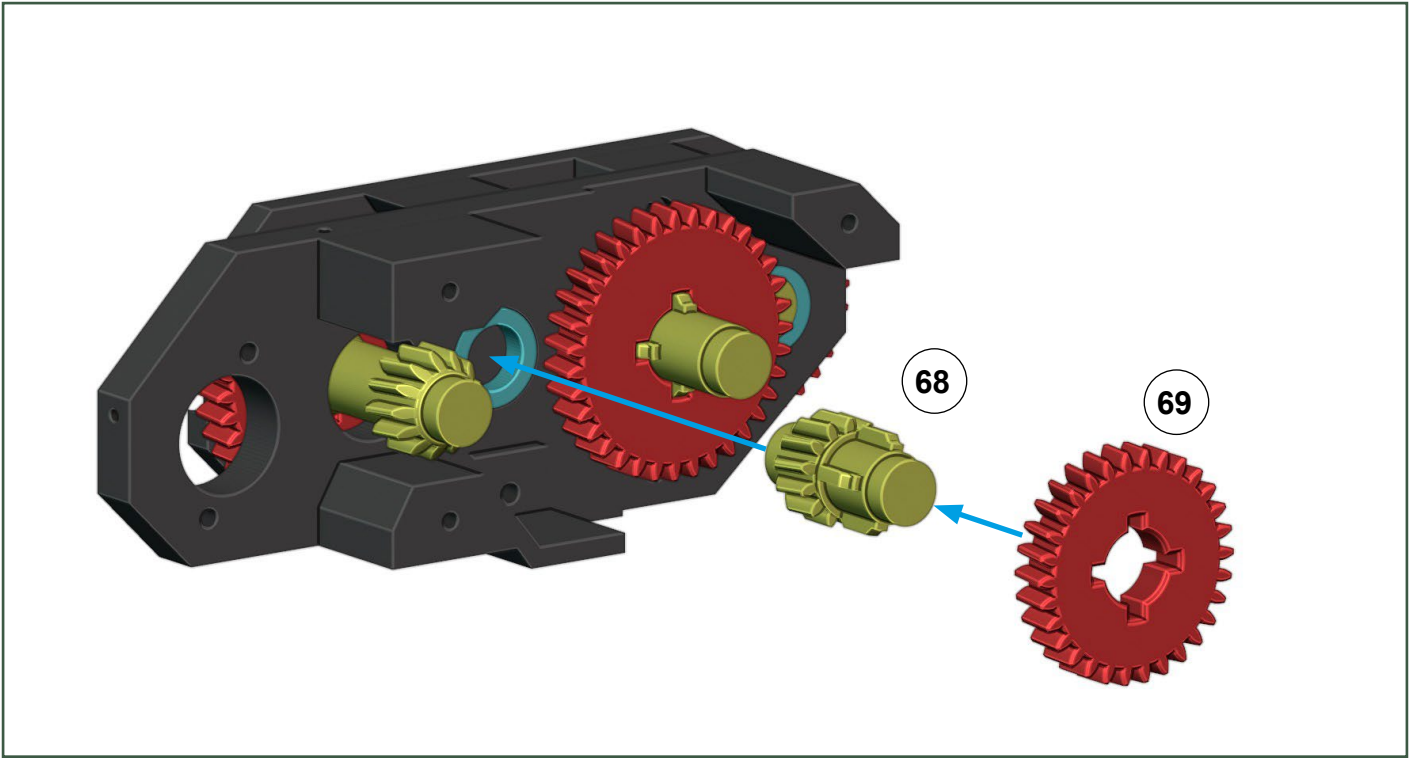

Gearbox left:

3x ball bearing 10x15x4

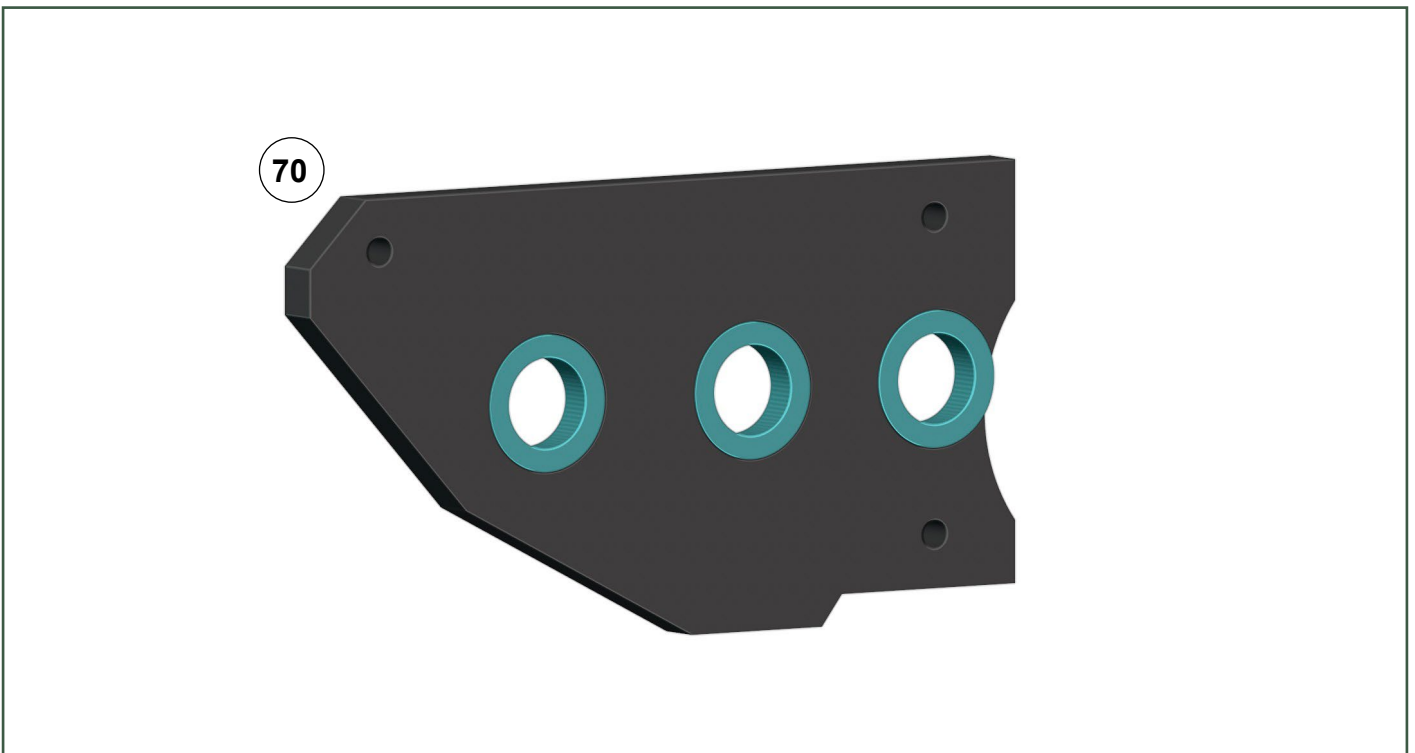

M4A3 Sherman – Build Guide

Gearbox left:

3x M3 screw 10 mm

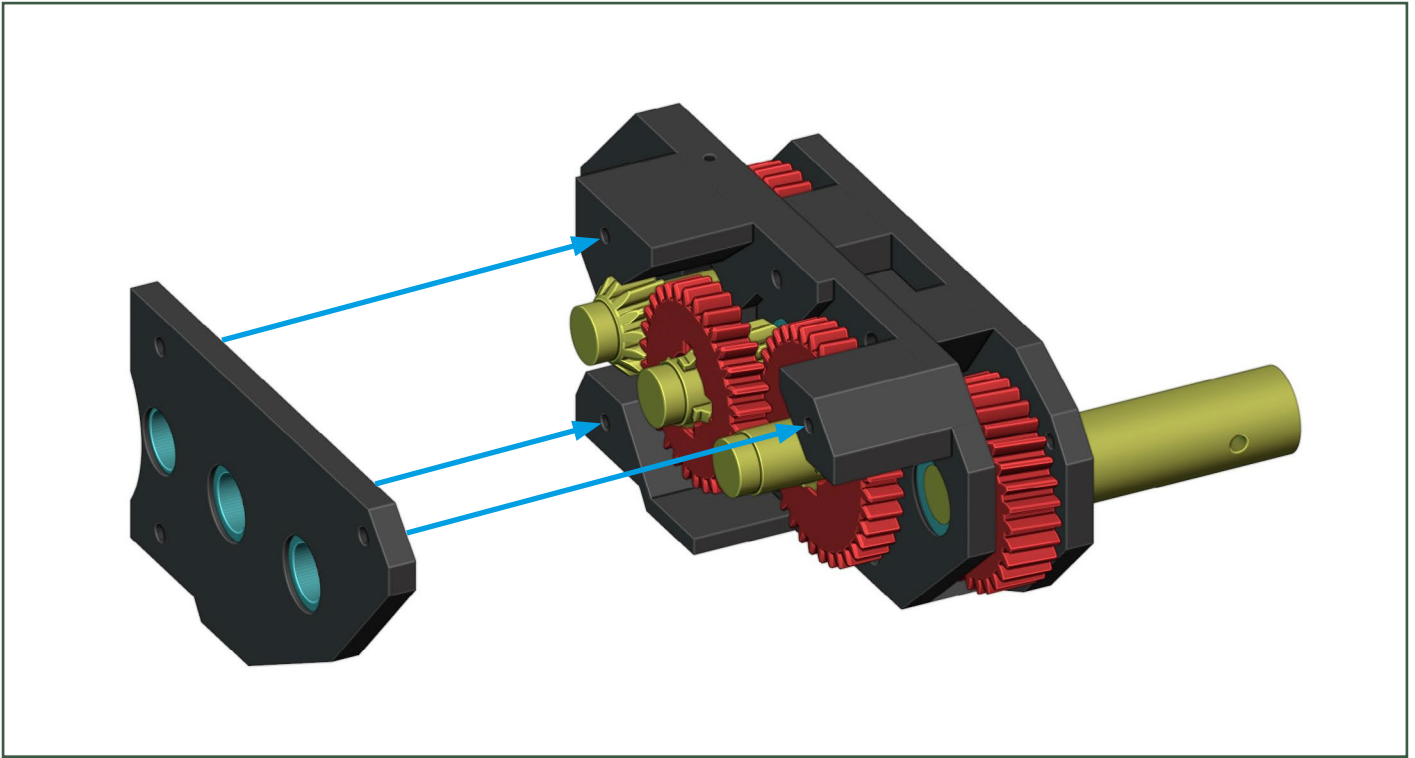

Gearbox left:

2x M3headless screw, 2x M3 nut, washer from 3 mm plywood (to prevent heat transfer), drawing of the washer is in “podlozka motoru.pdf” file.

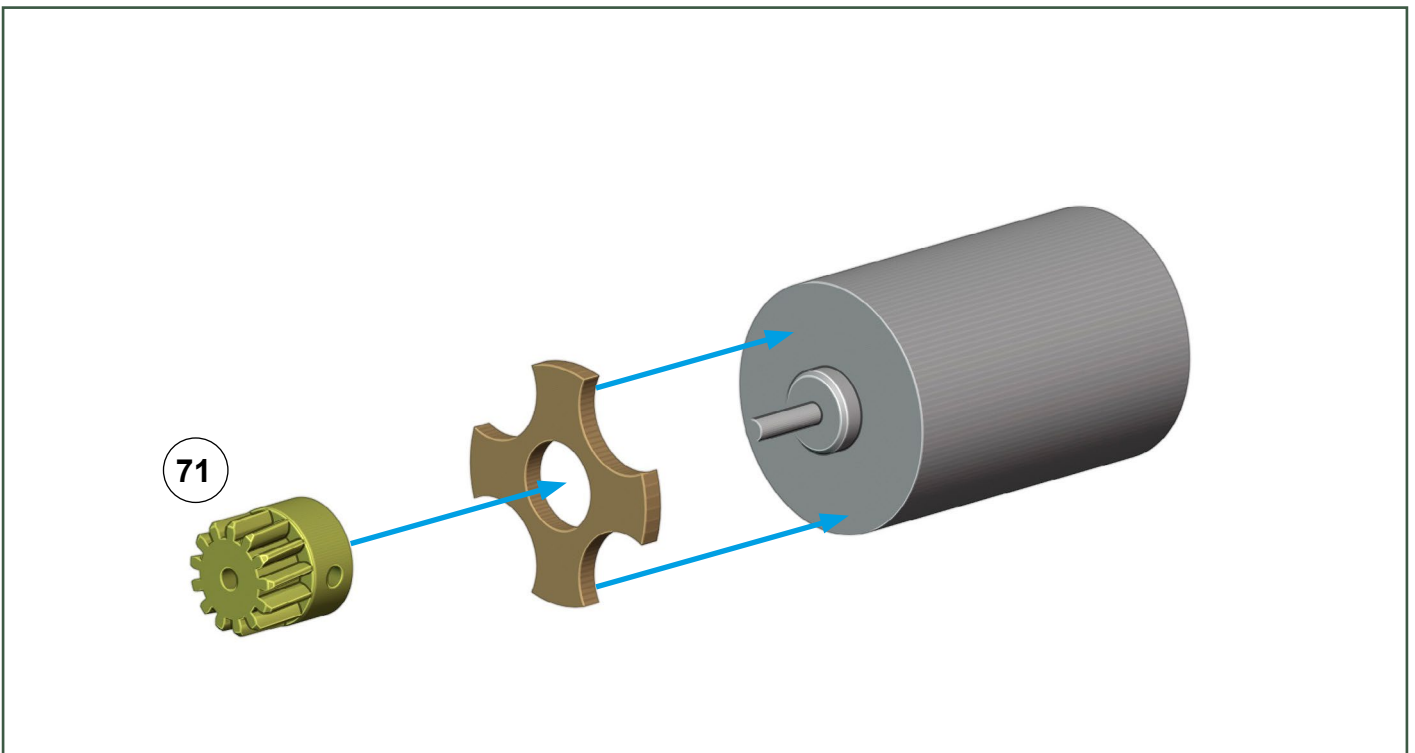

M4A3 Sherman - Build Guide

Gearbox left:

2x M3 screw 12 mm

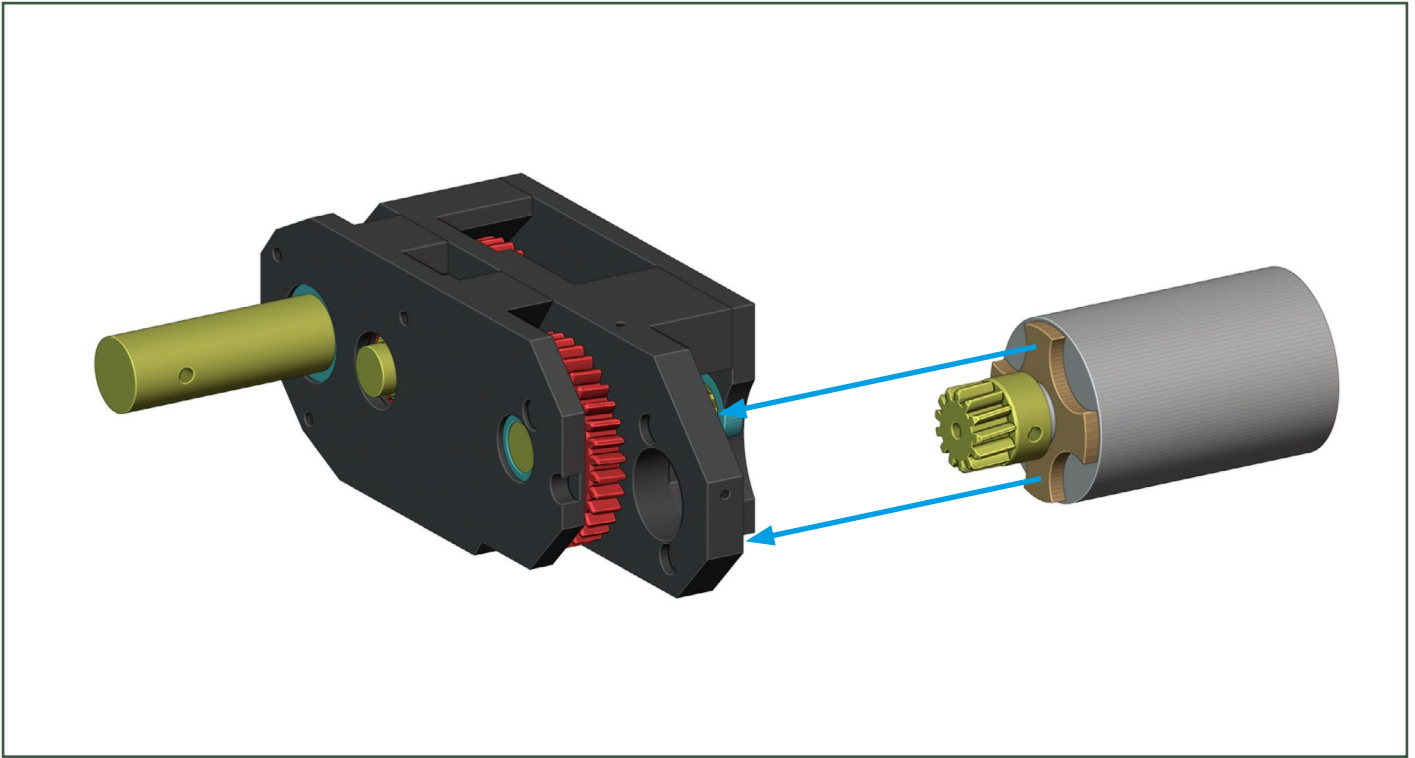

Gearbox left:

2x M2 screw 6 mm

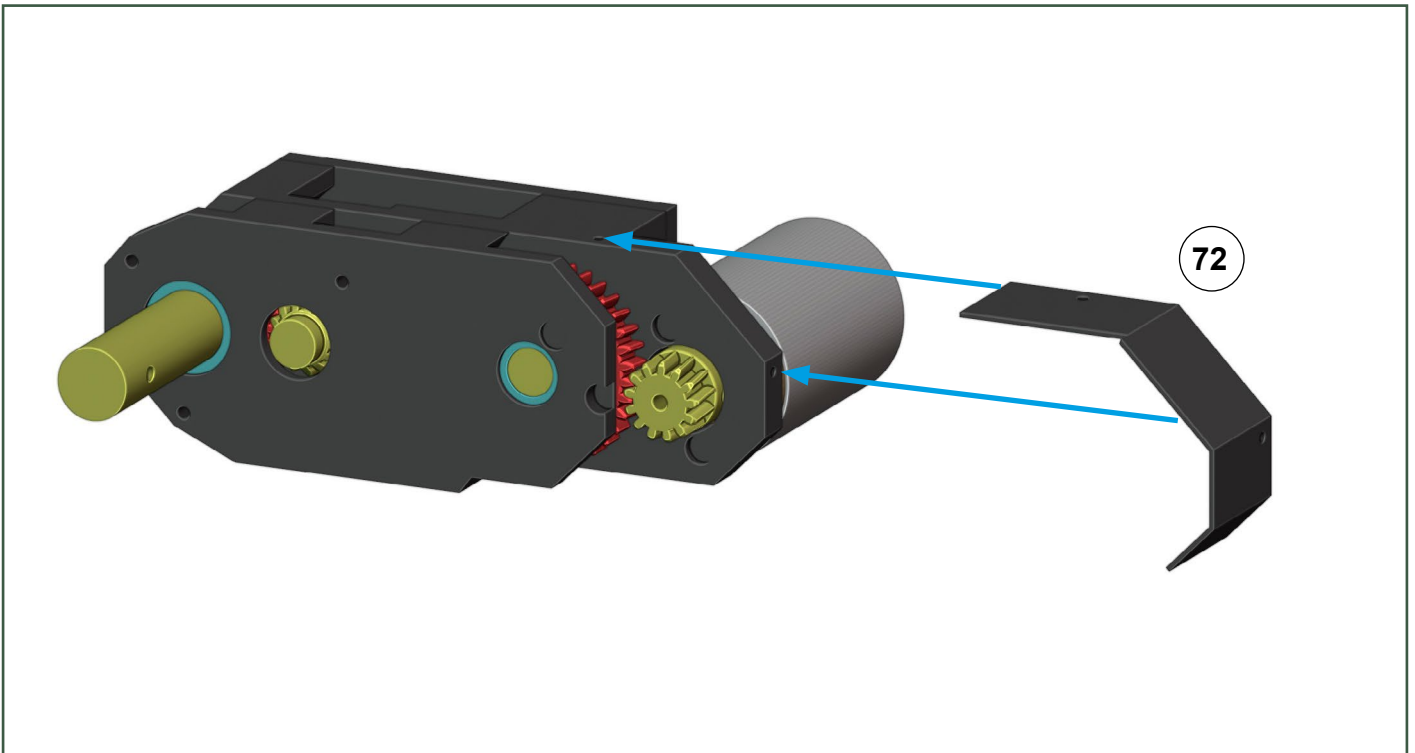

M4A3 Sherman - Build Guide

Gearbox right:

ball bearing 10x15x4 and 15x21x4

← use glue

← do not glue

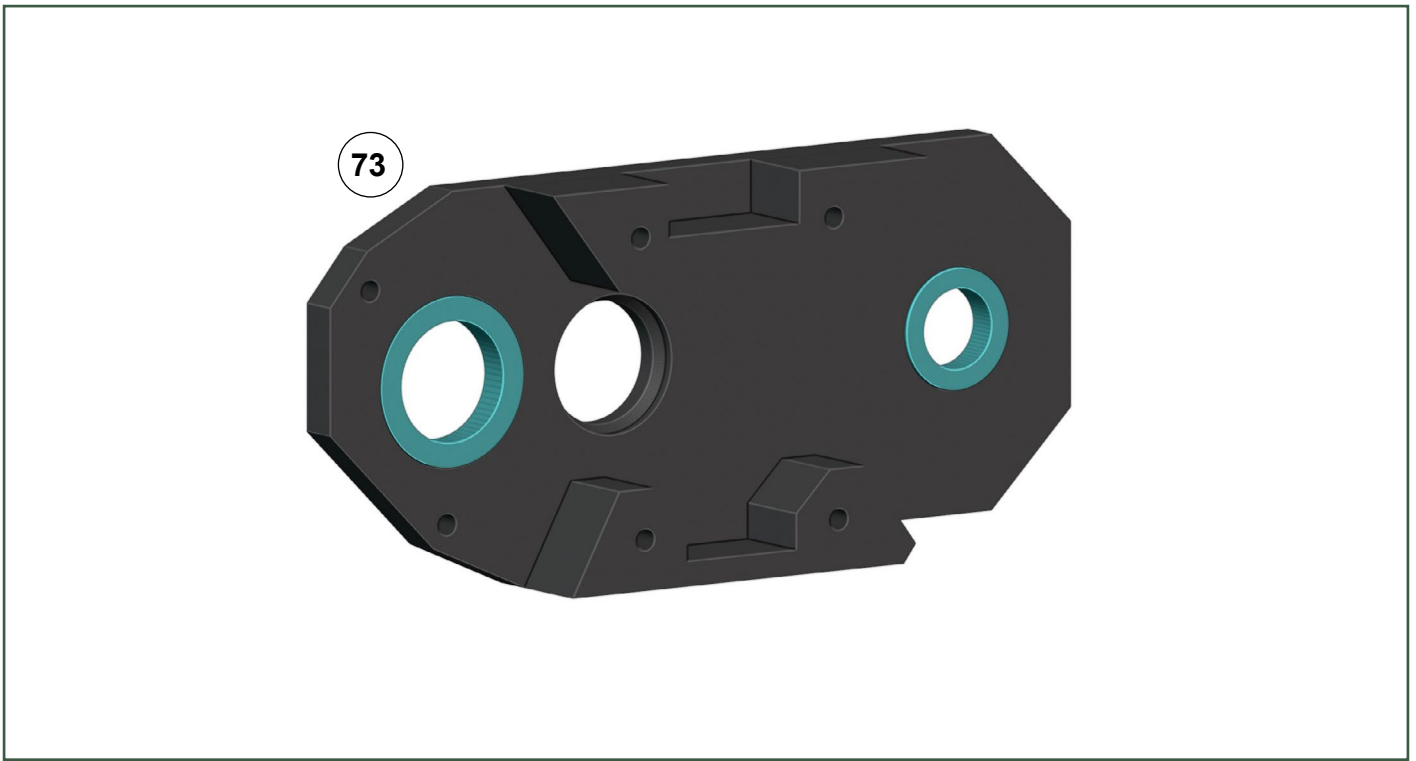

Gearbox right:

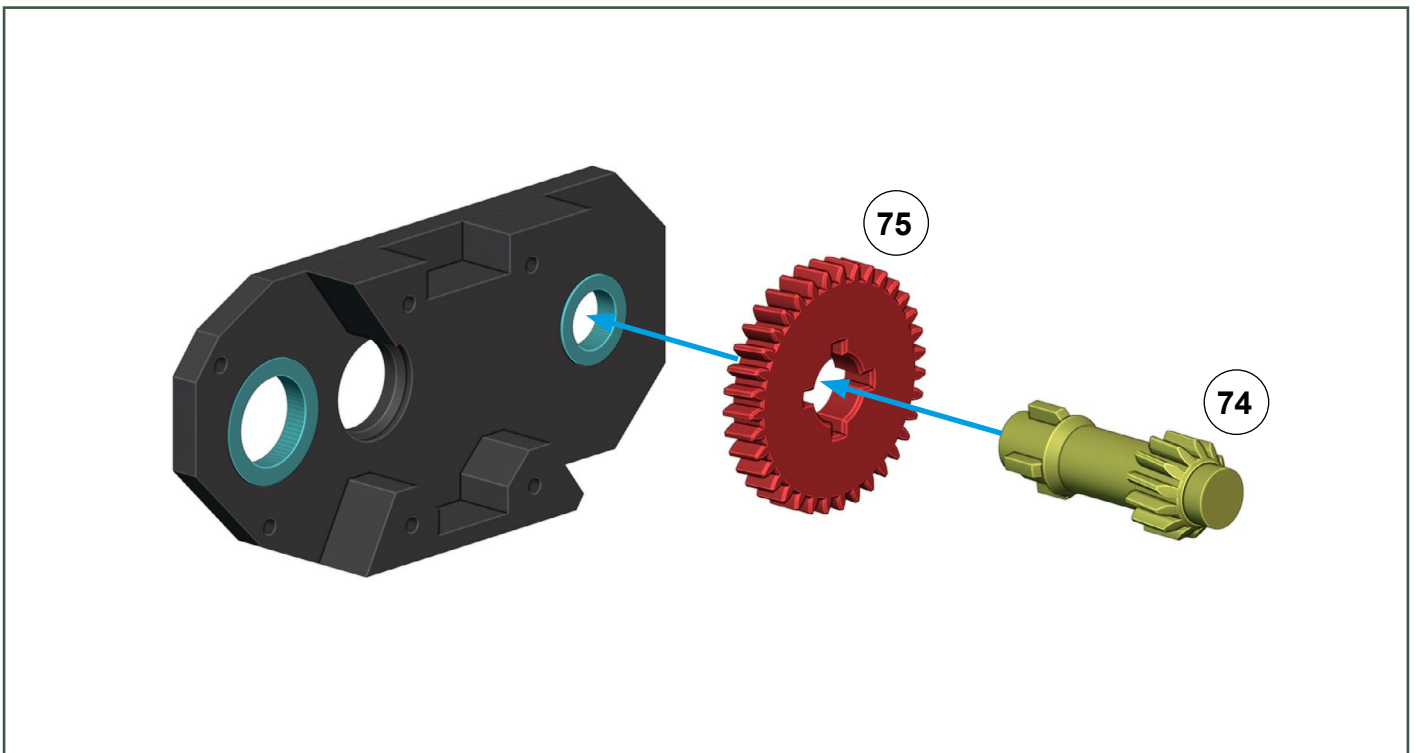

M4A3 Sherman - Build Guide

Gearbox right:

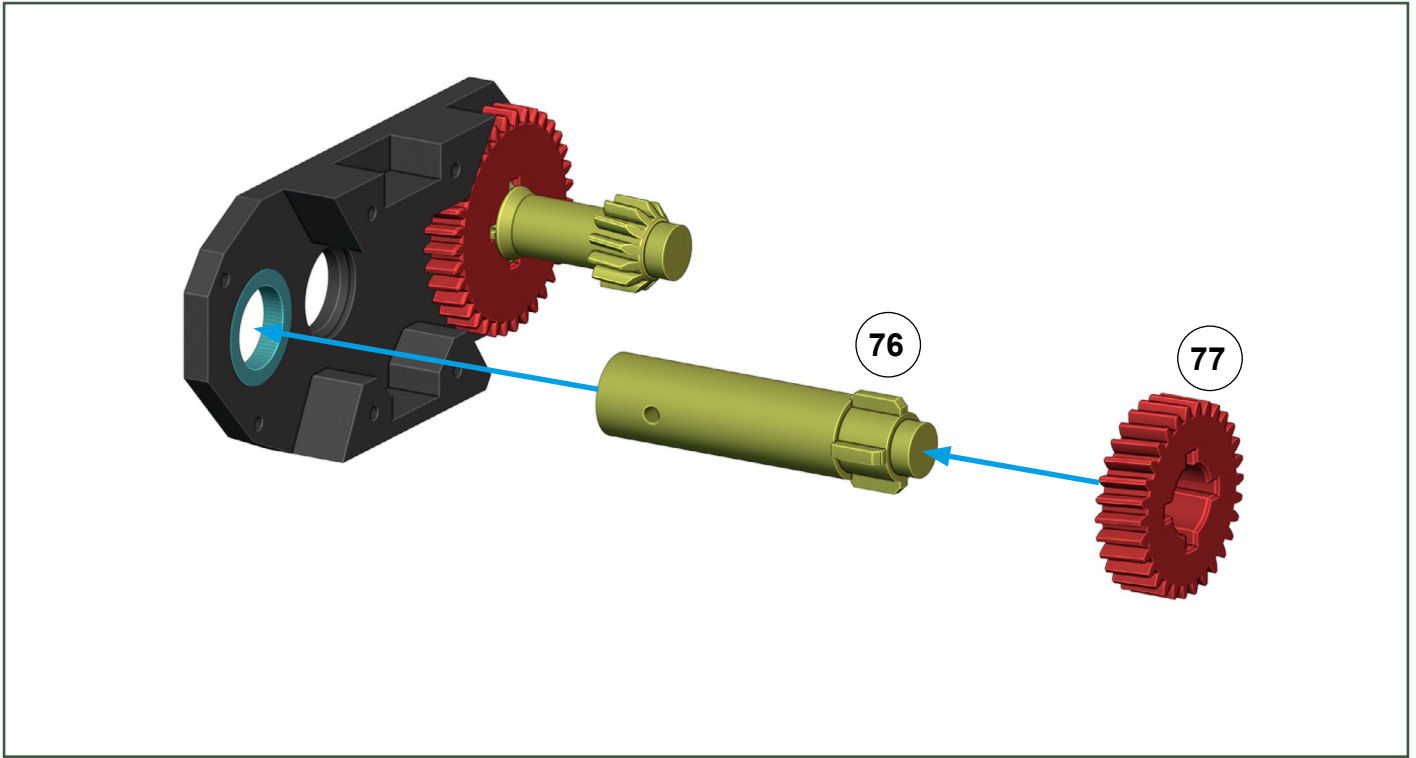

Gearbox right:

2x ball bearing 10x15x4

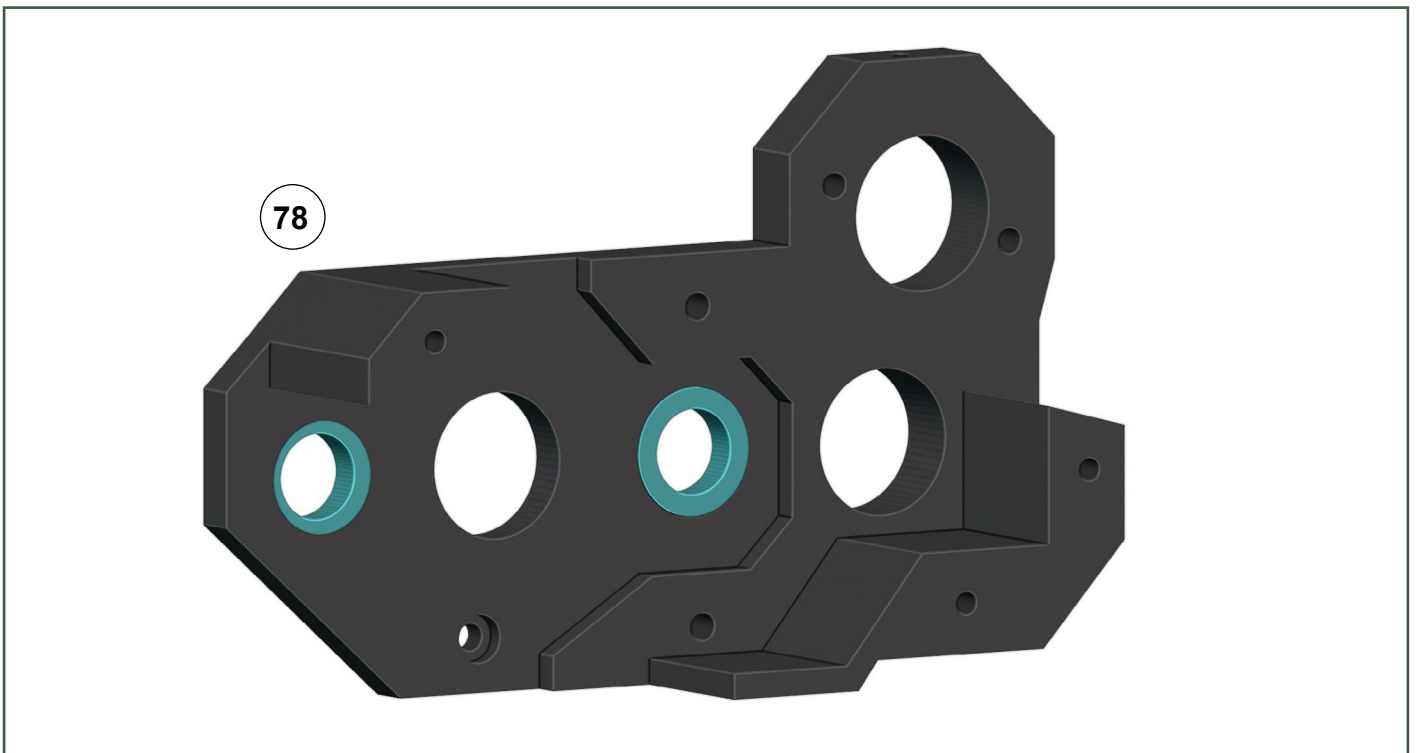

M4A3 Sherman - Build Guide

Gearbox right:

2x M3 screw 10 mm, 2x M3 screw 12 mm

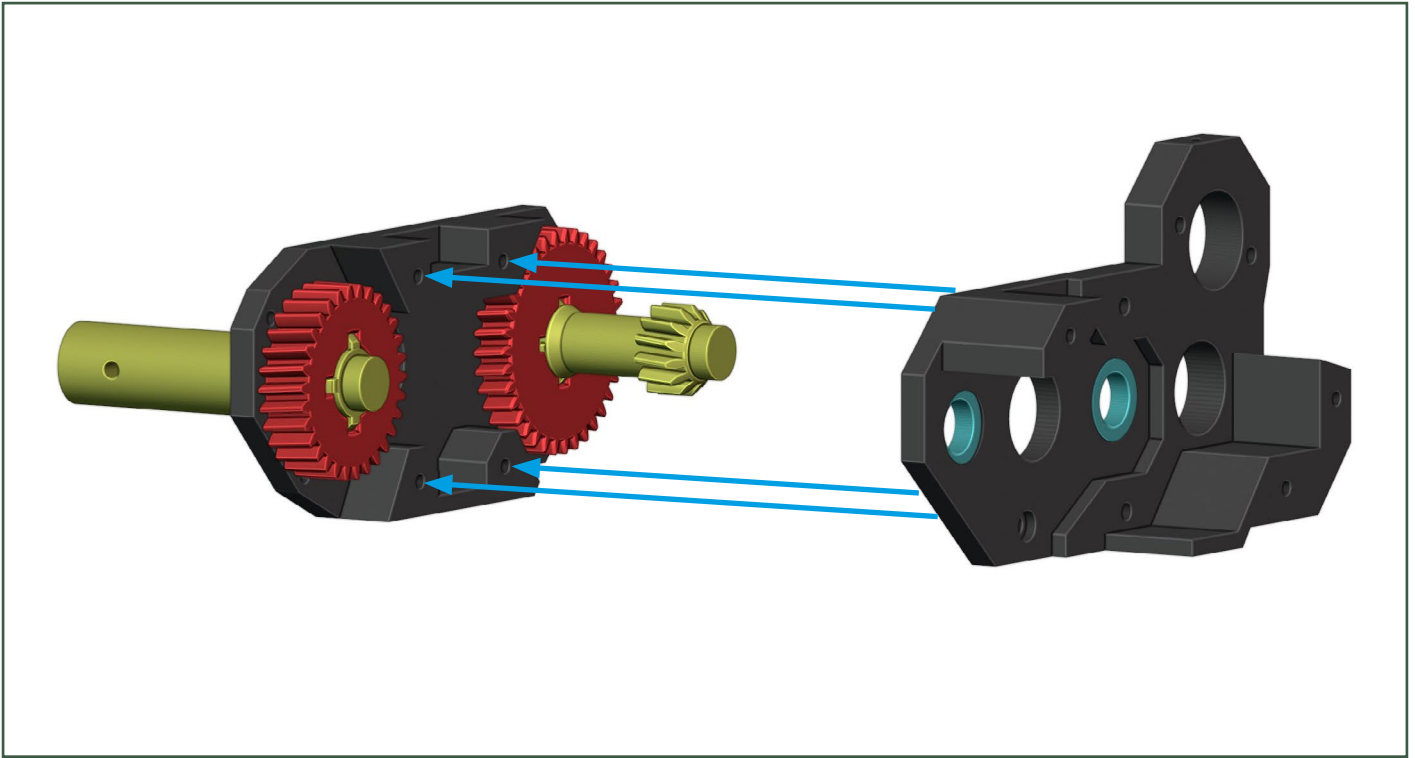

Gearbox right:

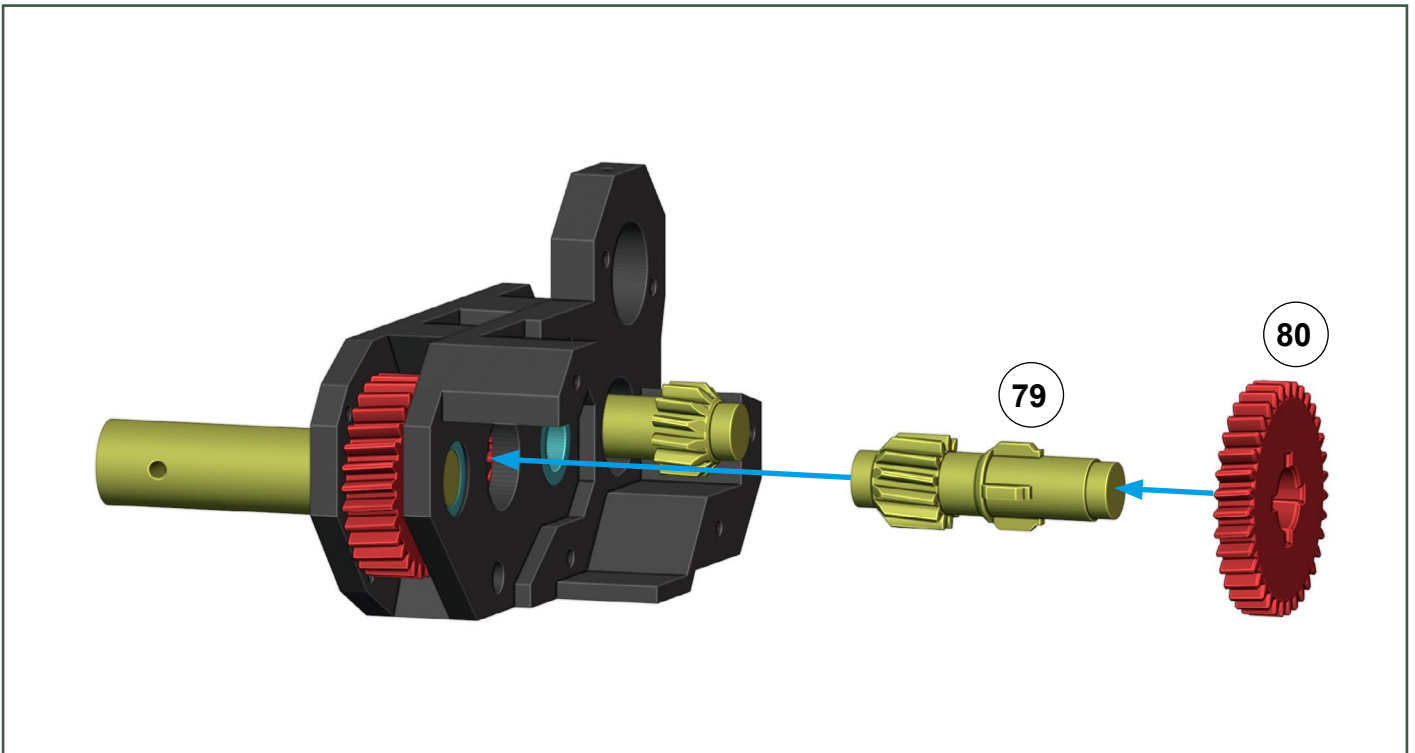

M4A3 Sherman - Build Guide

Gearbox right:

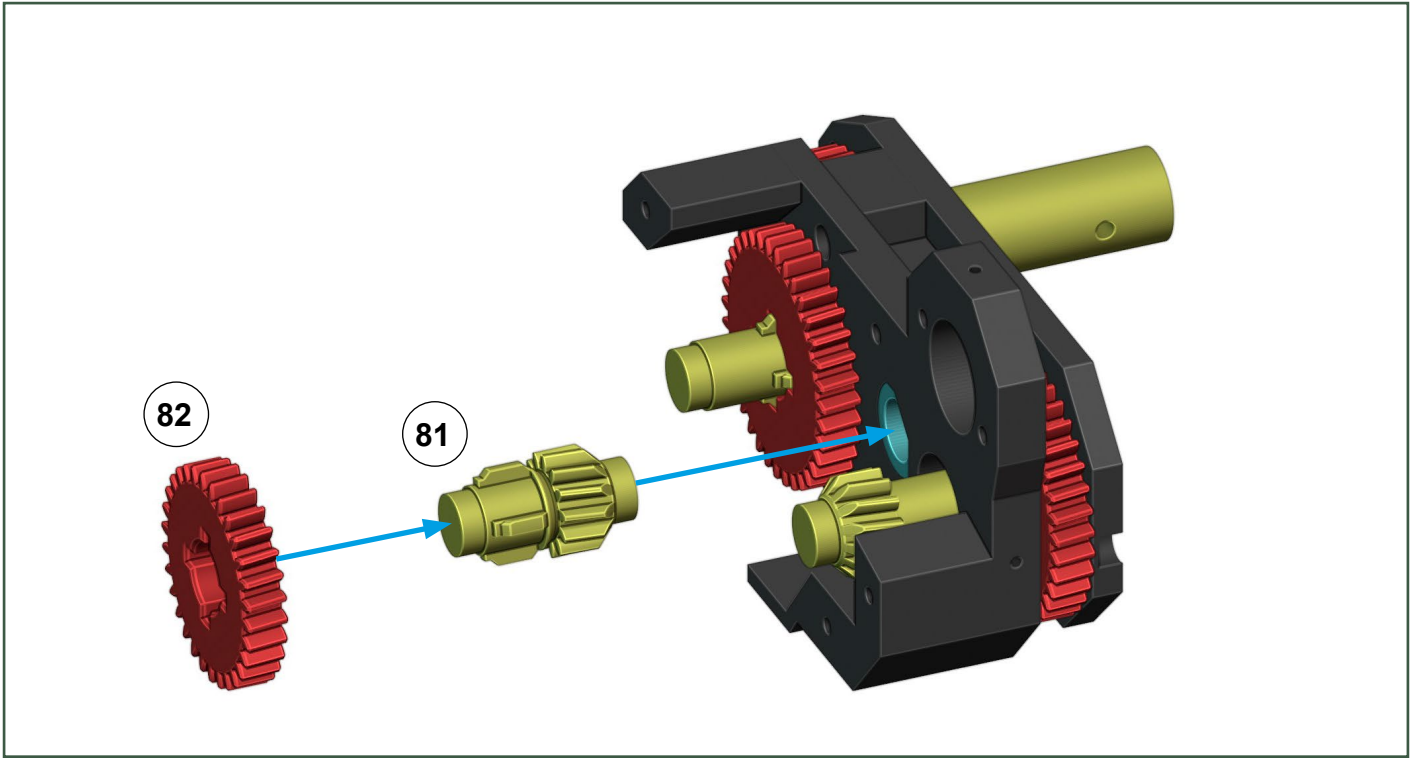

Gearbox right:

3x ball bearing 10x15x4

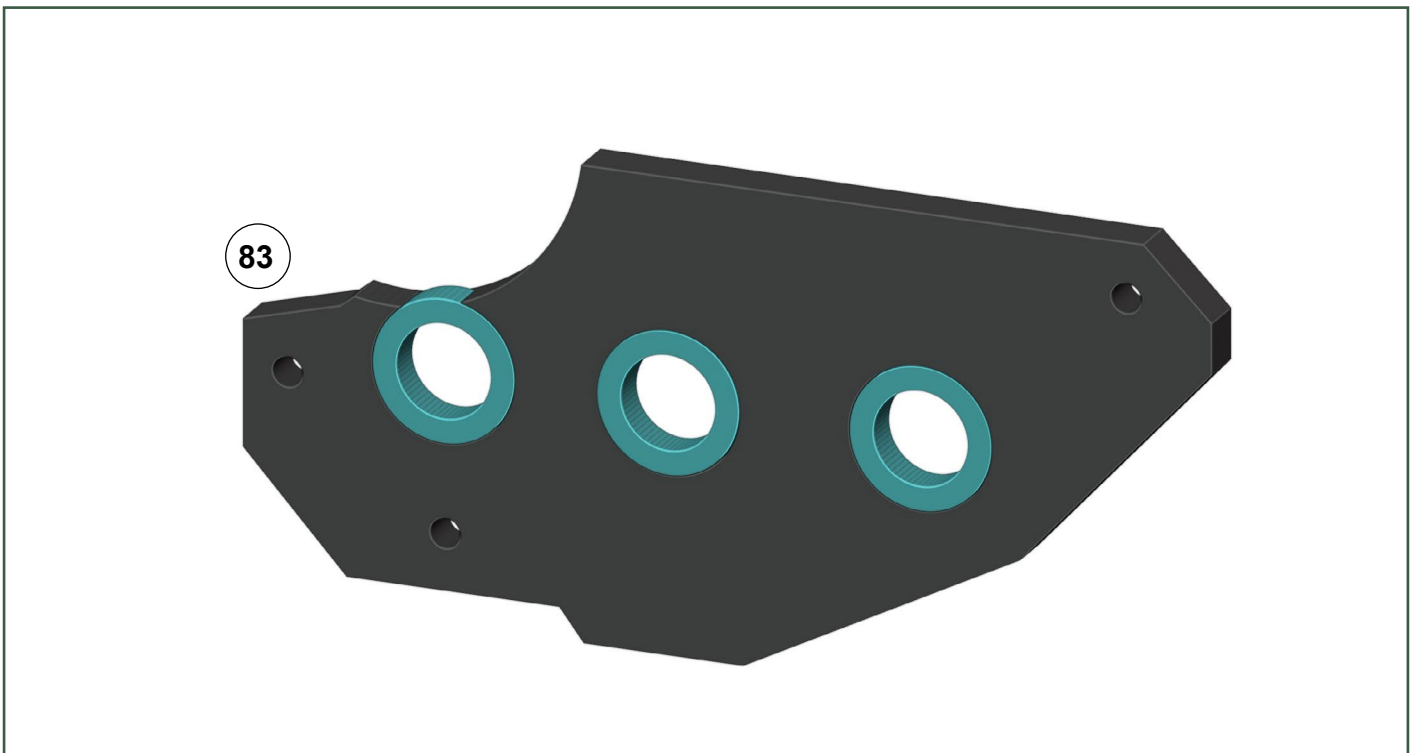

M4A3 Sherman - Build Guide

Gearbox right:

3x M3 screw 10 mm

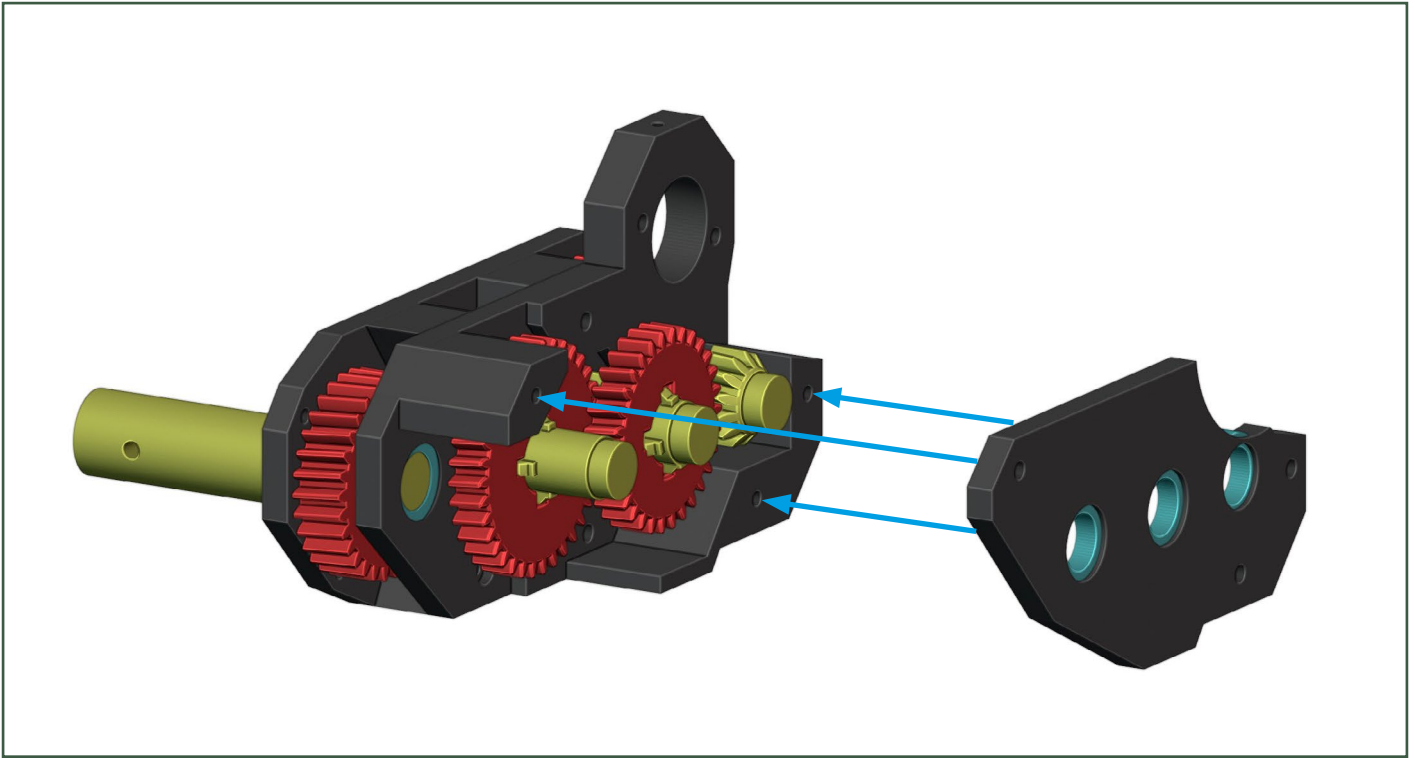

Gearbox right:

2x M3 headless screw, 2x M3 nut, washer from 3 mm plywood

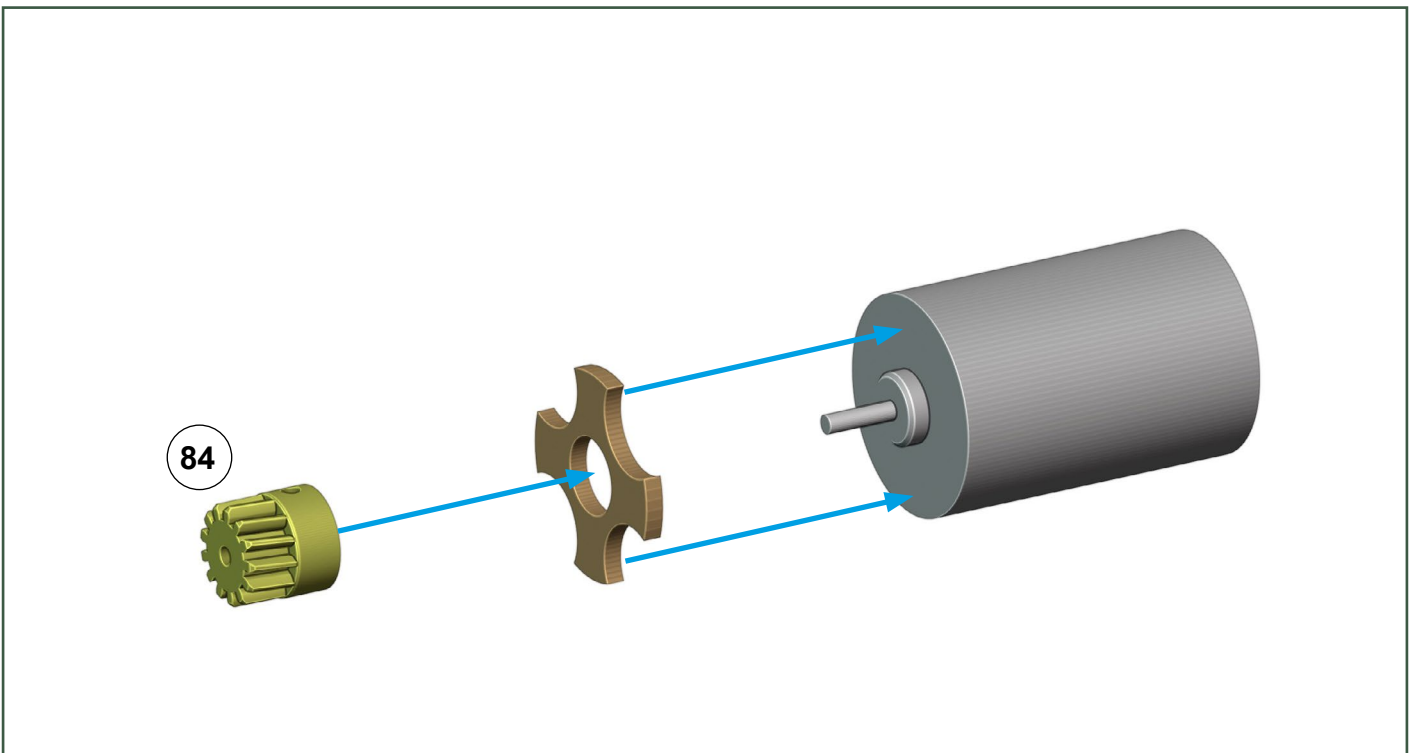

M4A3 Sherman - Build Guide

Gearbox right:

2x M3 screw 12 mm

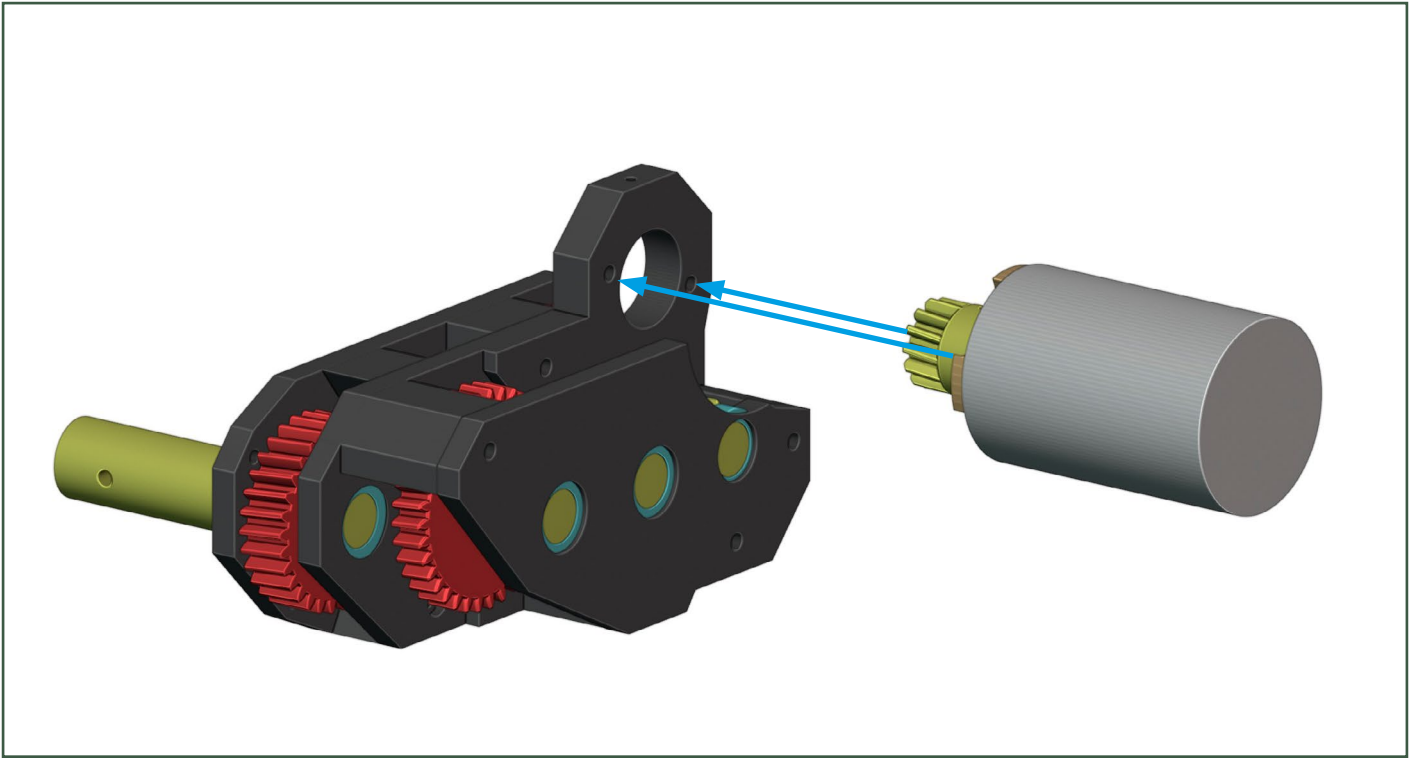

Gearbox right:

2x M2 screw 6 mm

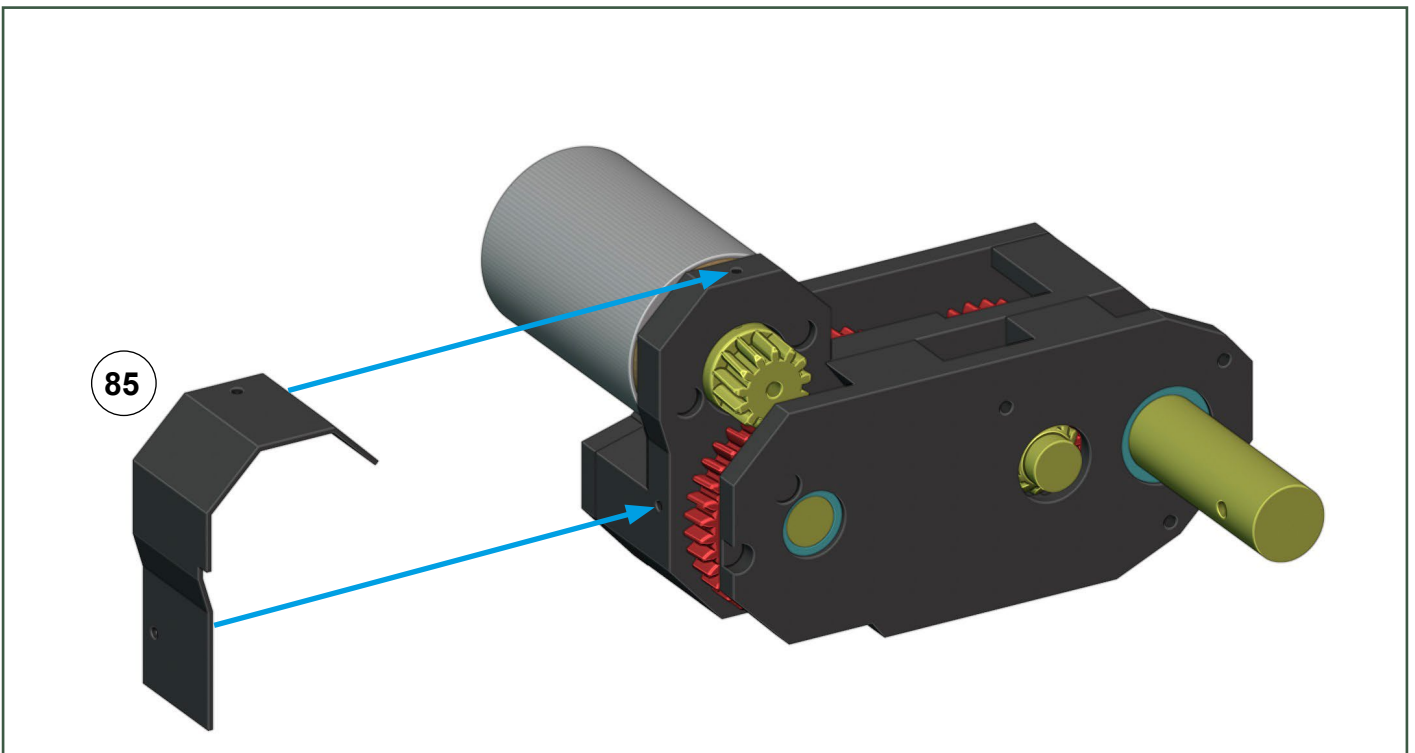

M4A3 Sherman - Build Guide

Gearbox right:

ball bearing 10x15x4

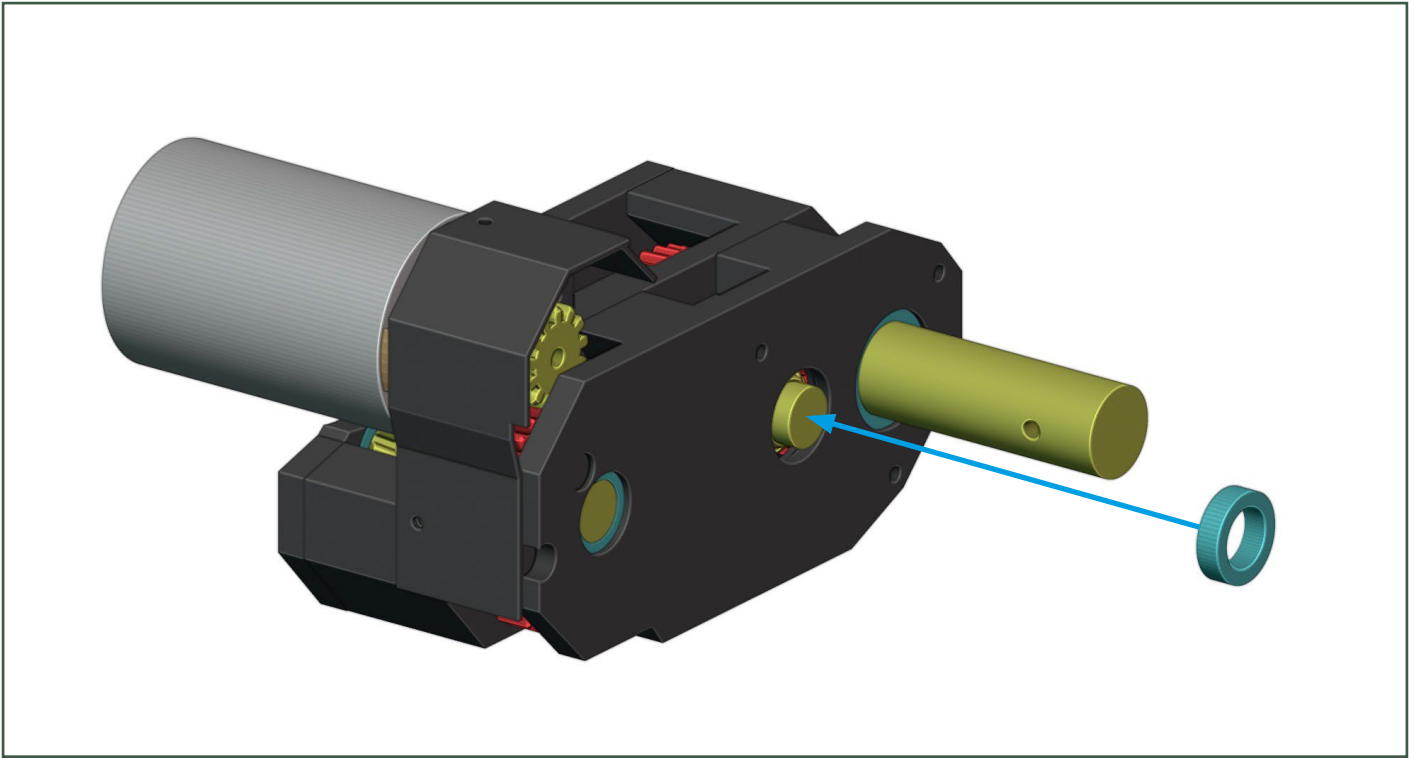

Gearbox left:

ball bearing 10x15x4

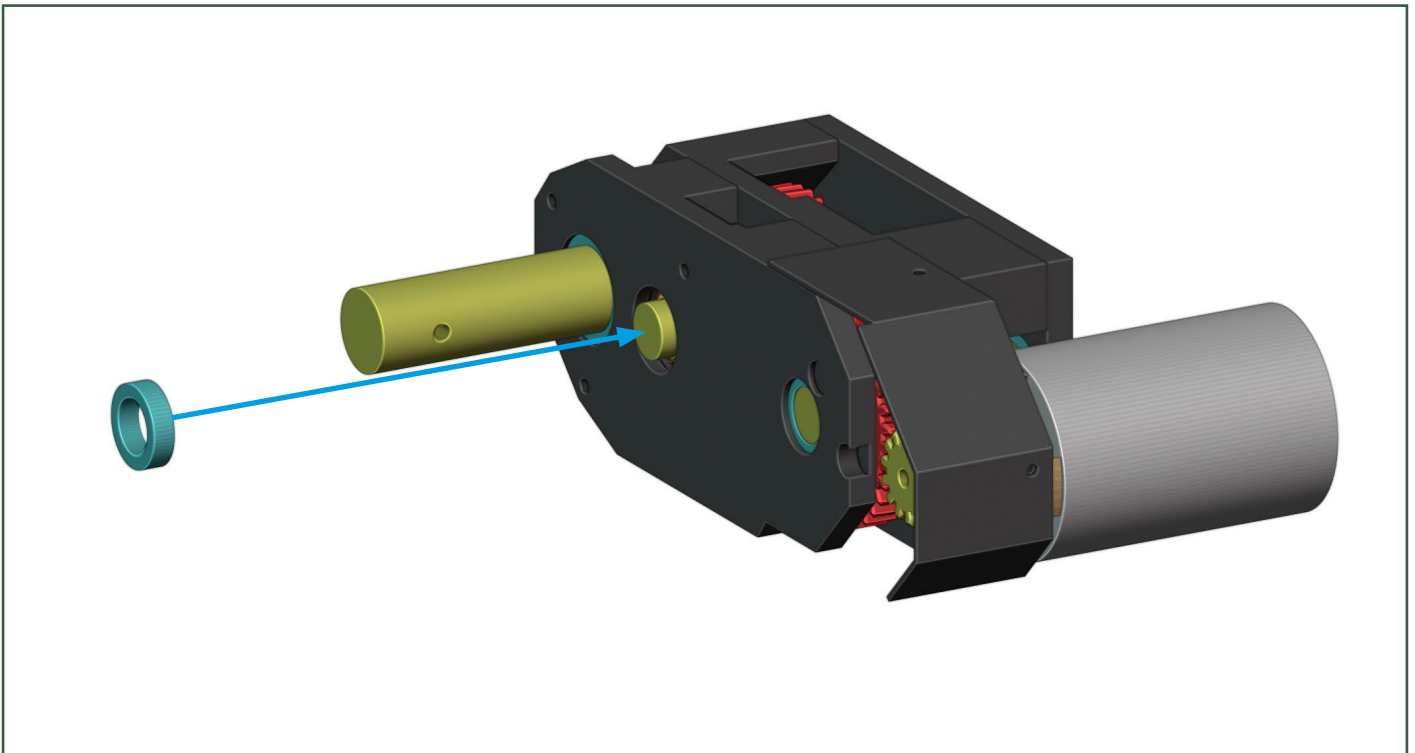

M4A3 Sherman - Build Guide

Gearbox left:

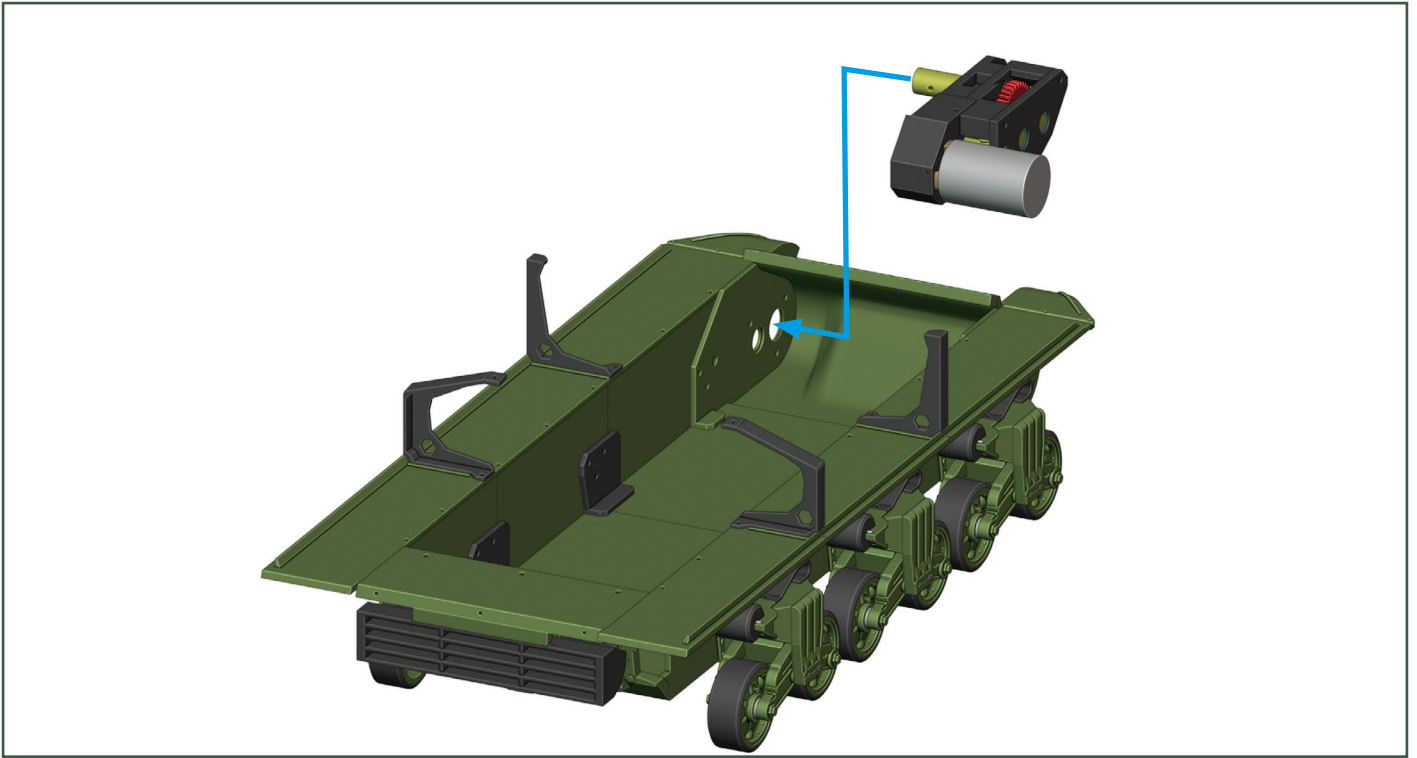

Gearbox right:

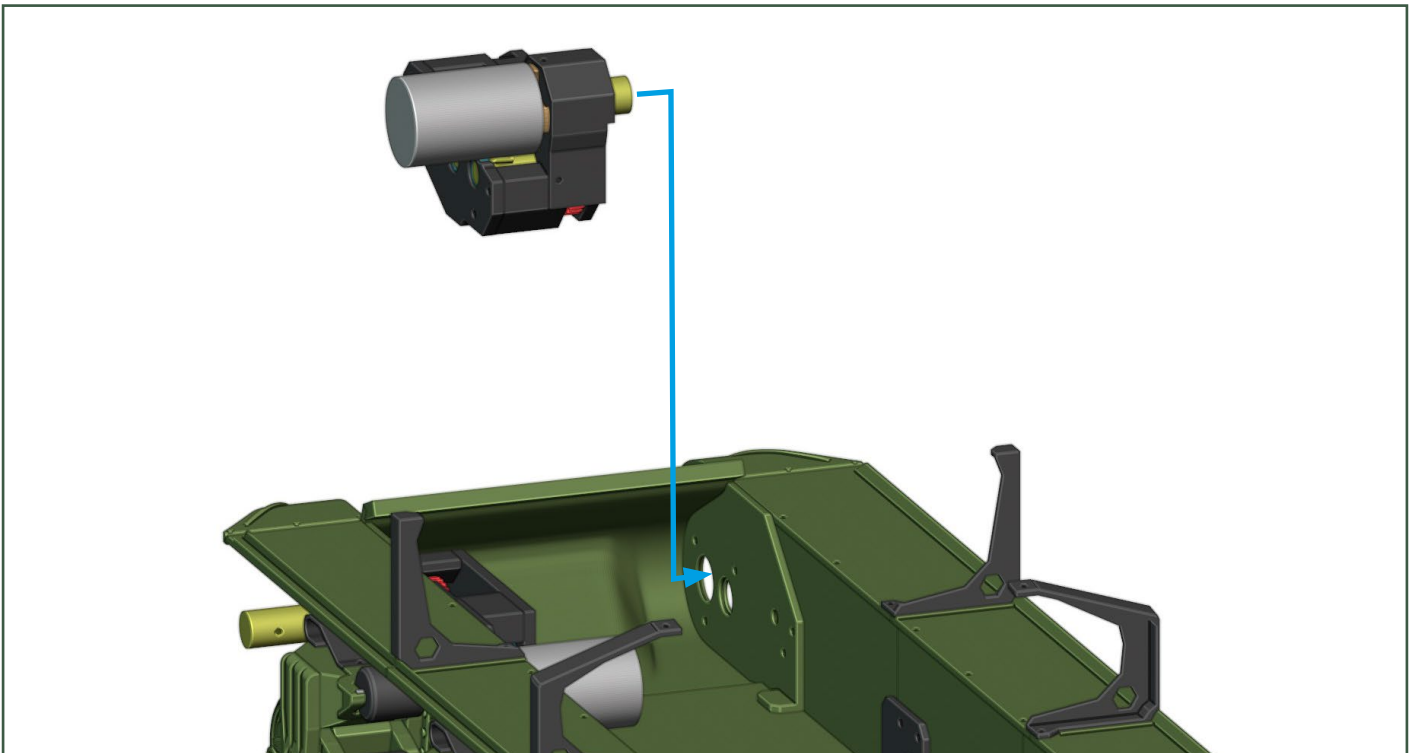

M4A3 Sherman - Build Guide

Hull:

ball bearing 15x21x4

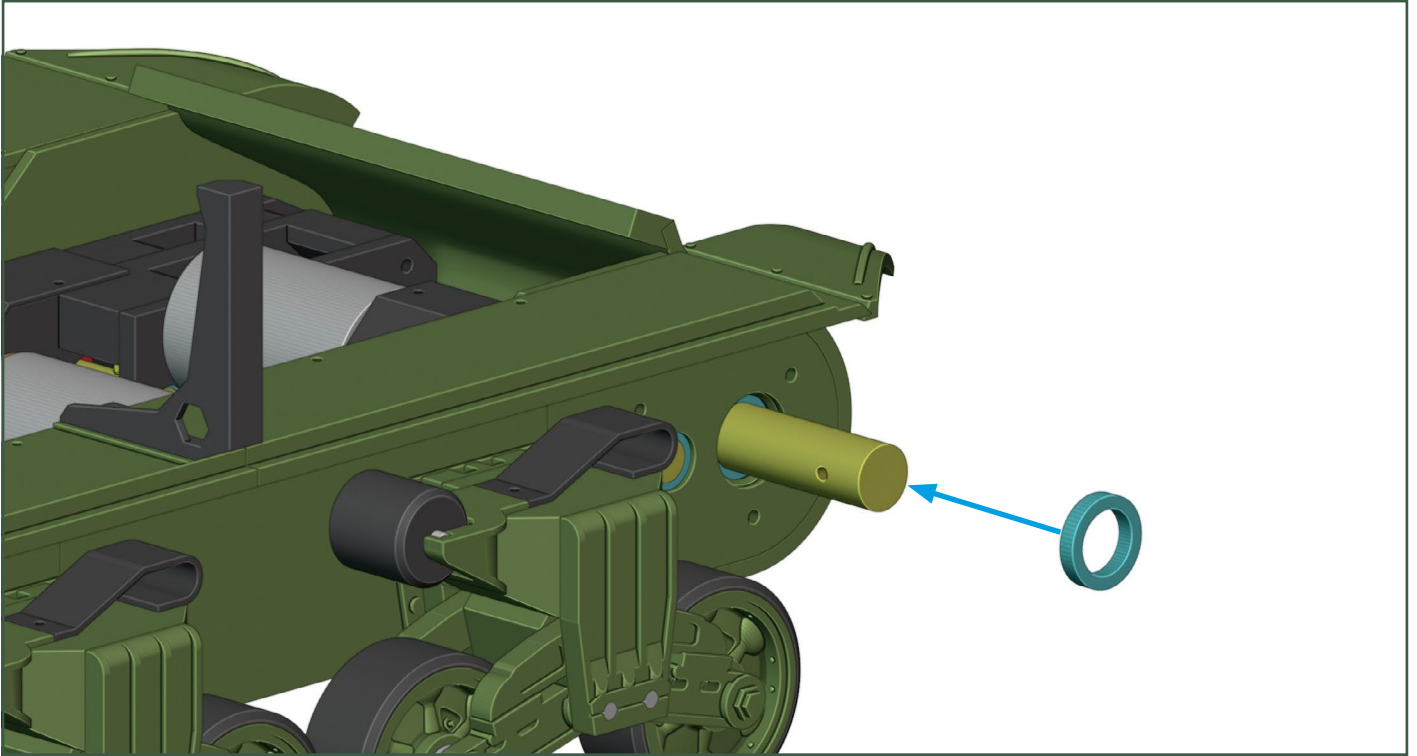

Hull:

ball bearing 15x21x4

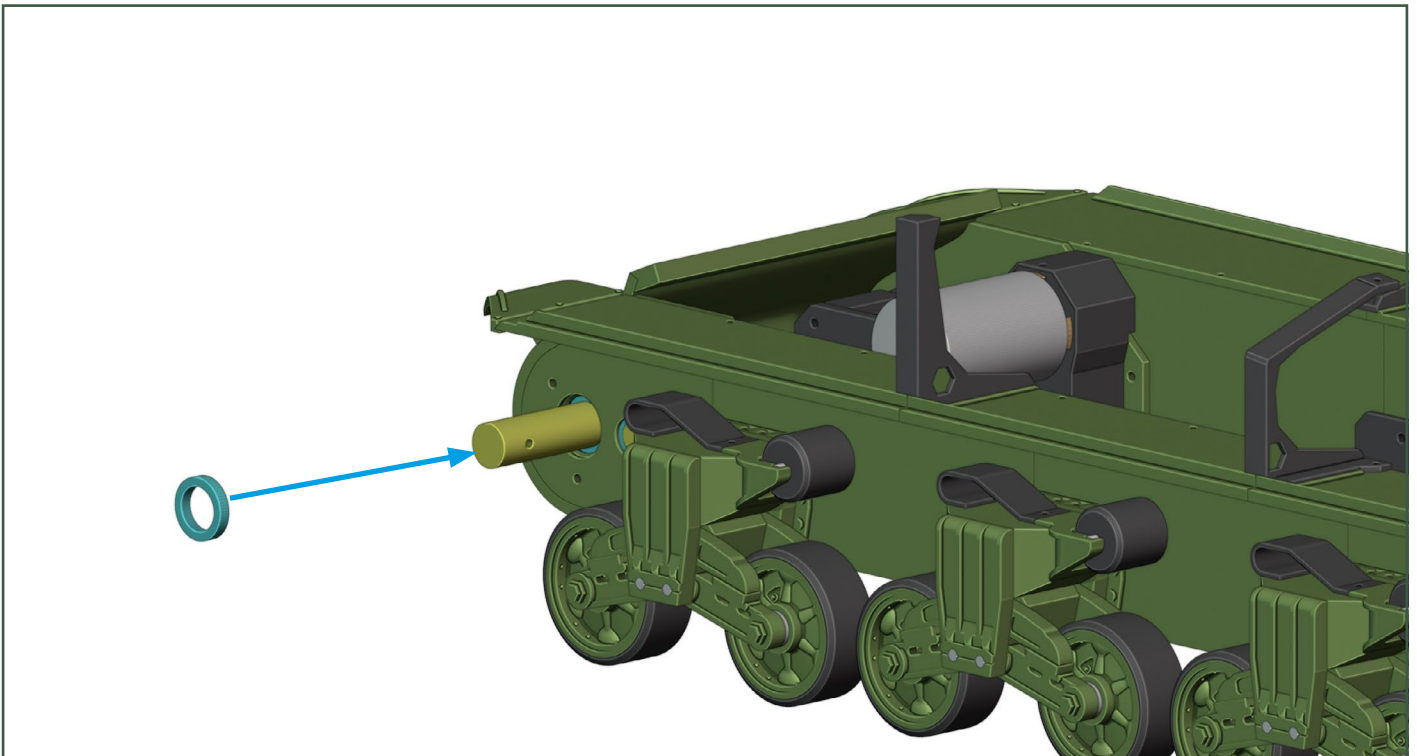

M4A3 Sherman - Build Guide

Hull:

M3 screw 14 mm, 2x M3 screw 10 mm (front holes)

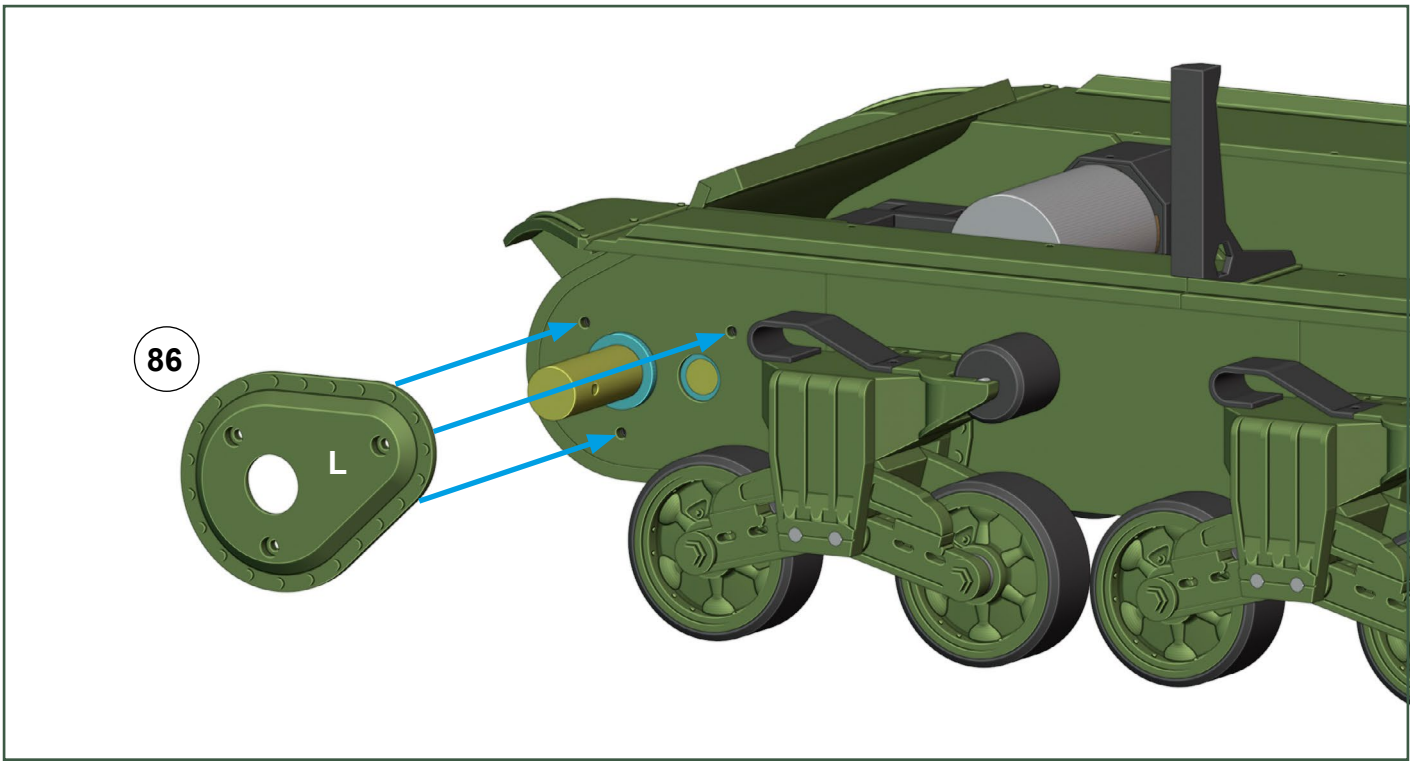

Hull:

M3 screw 14 mm, 2x M3 screw 10 mm

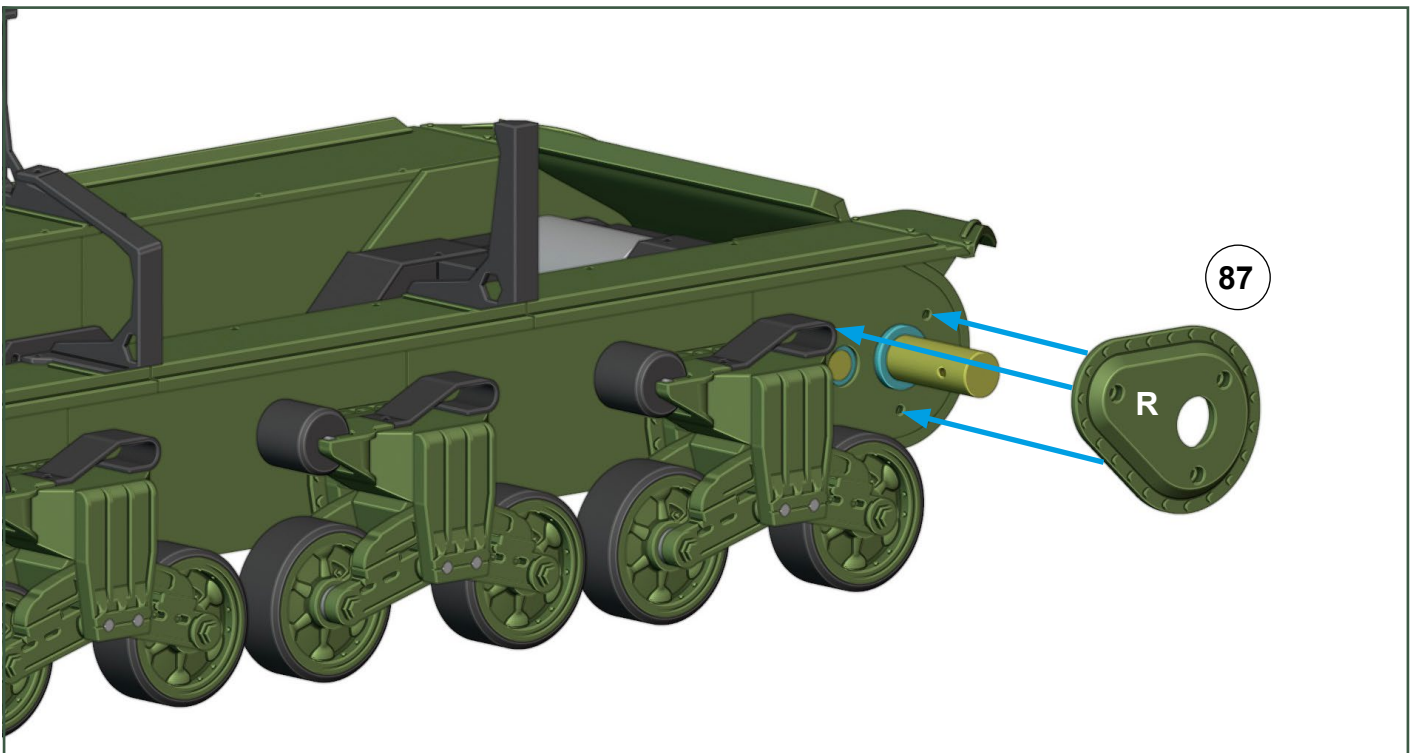

M4A3 Sherman - Build Guide

Wheels:

M3 screw 30 mm

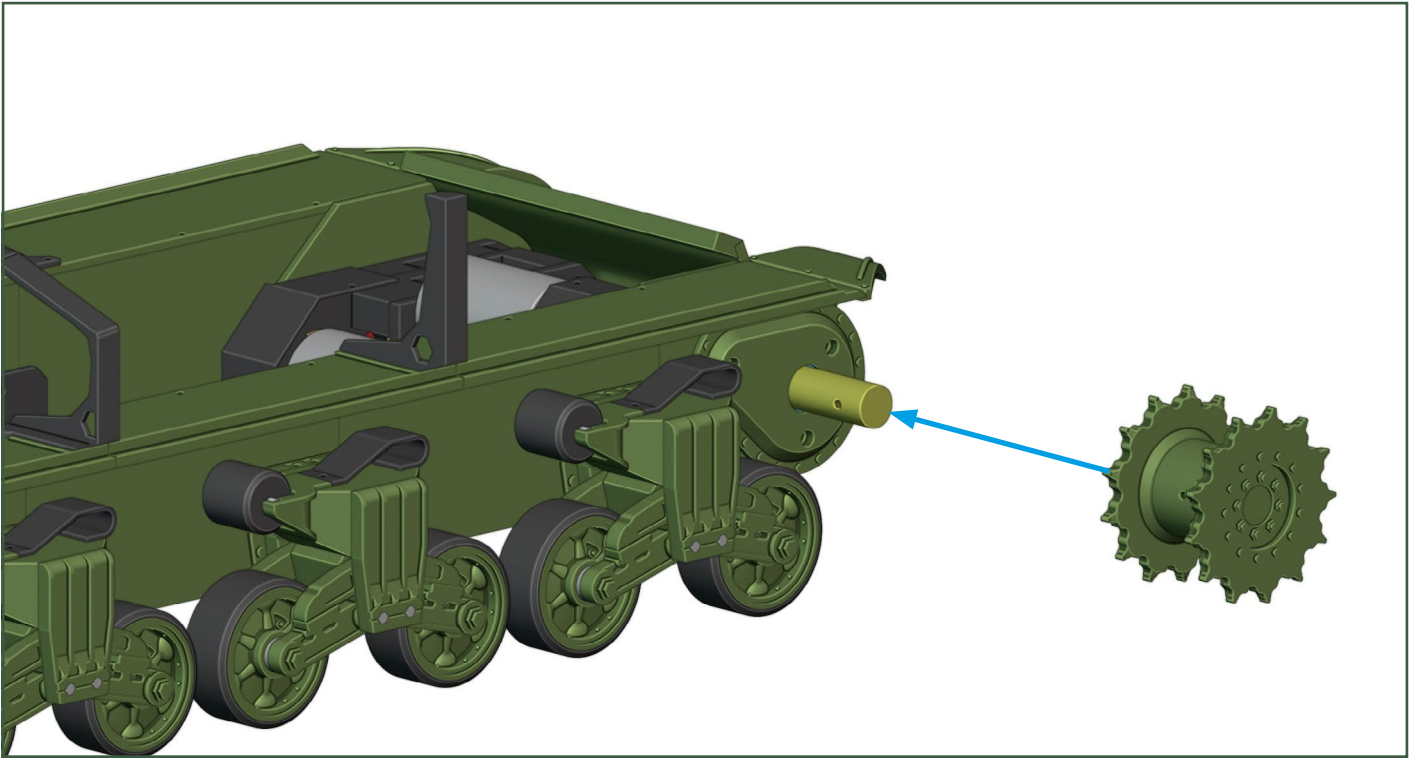

Wheels:

M3 screw 30 mm

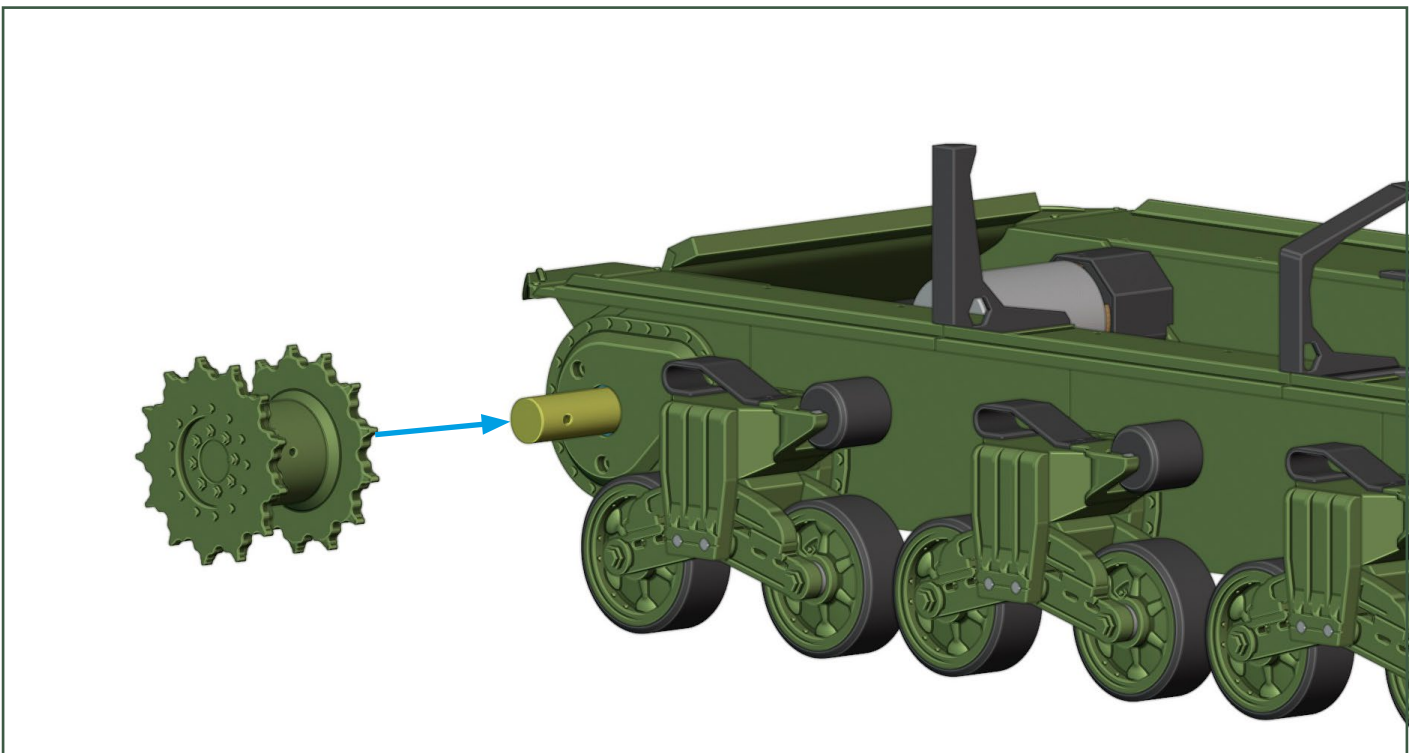

M4A3 Sherman – Build Guide

Wheels:

M2 screw 8 mm, tube 6x43,5 mm, inner dimension 4,3 mm

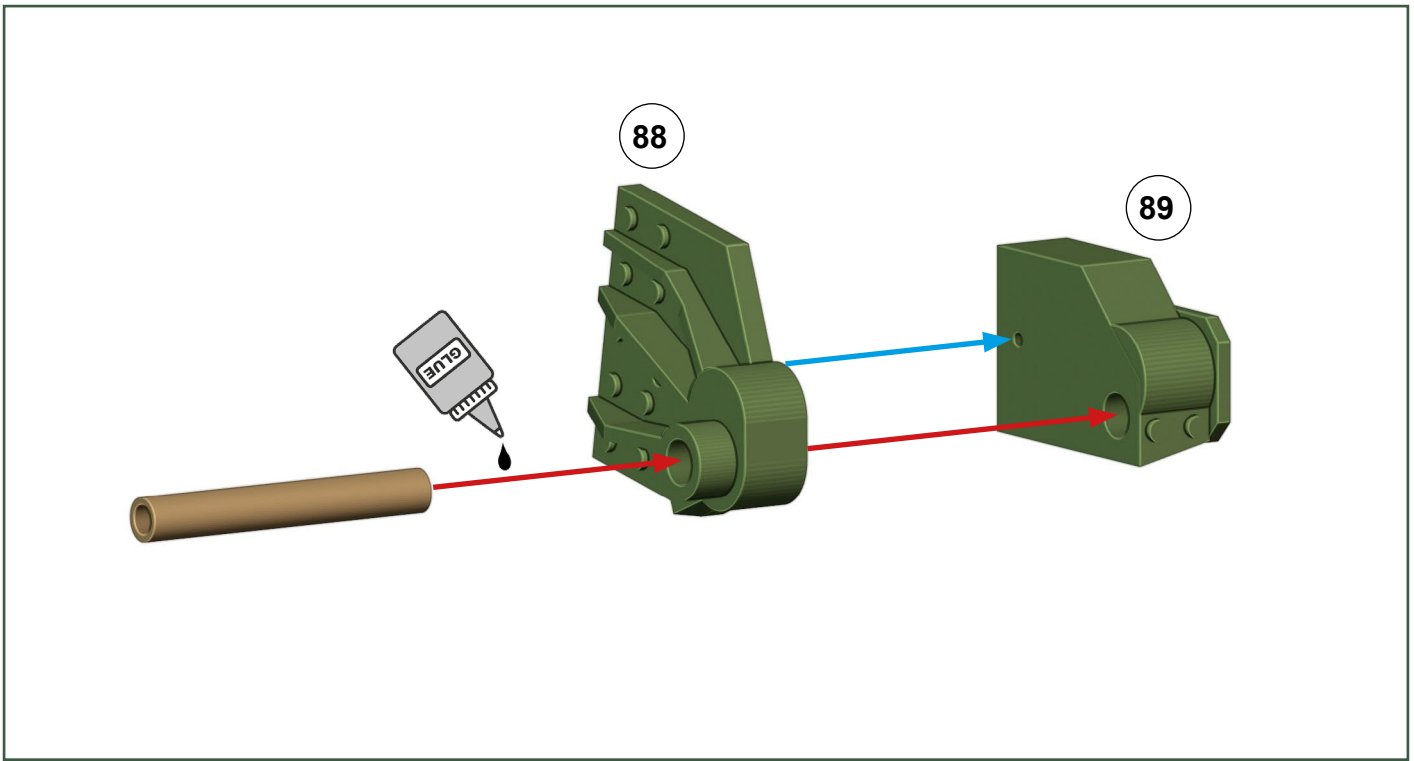

Wheels:

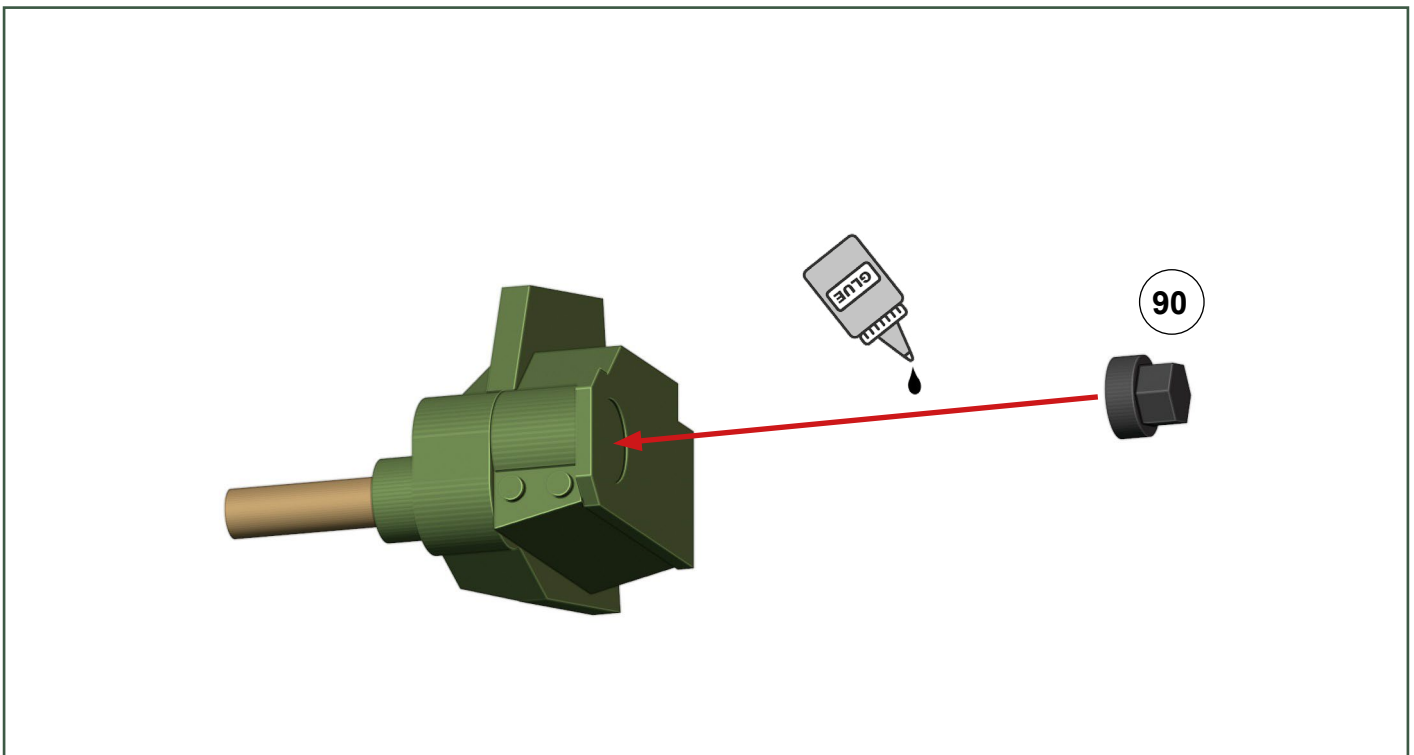

M4A3 Sherman – Build Guide

Wheels:

M2 screw 8 mm, tube 6x43,5 mm, inner dimension 4,3 mm

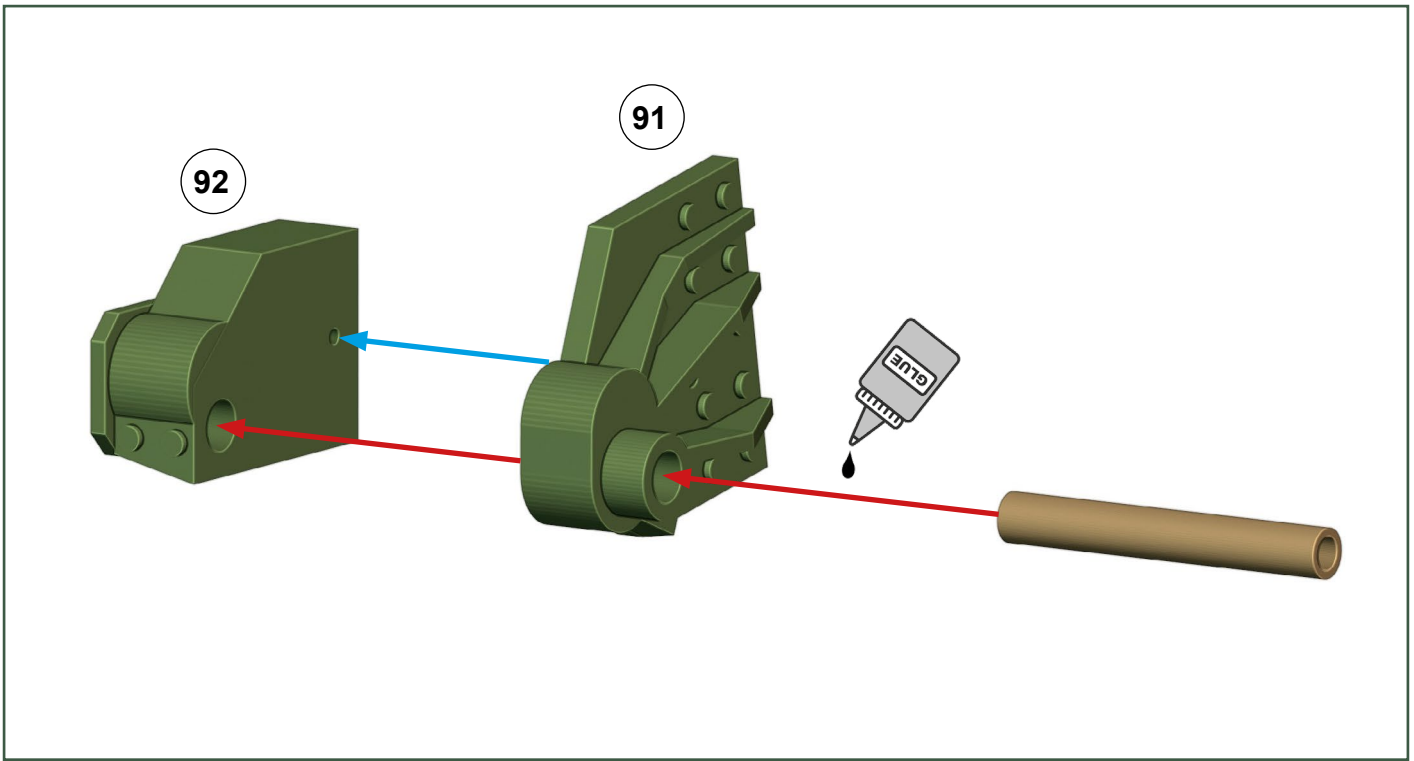

Wheels:

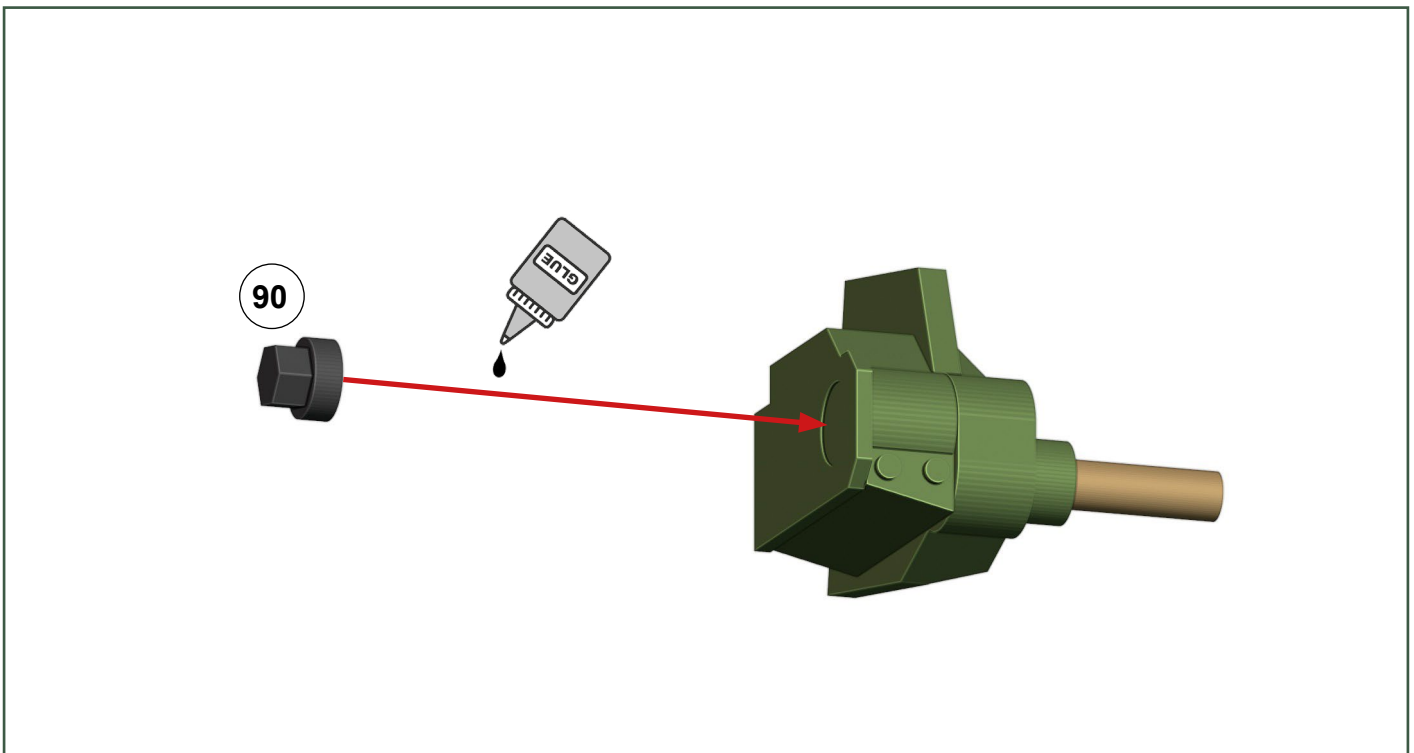

M4A3 Sherman – Build Guide

Wheels:

2x ball bearing 6x13x5, čep 15 zalepte do osy kola, krytku 16 trochu lepidla ke kolu 14. Stejná sestava je i pro pravou stranu.

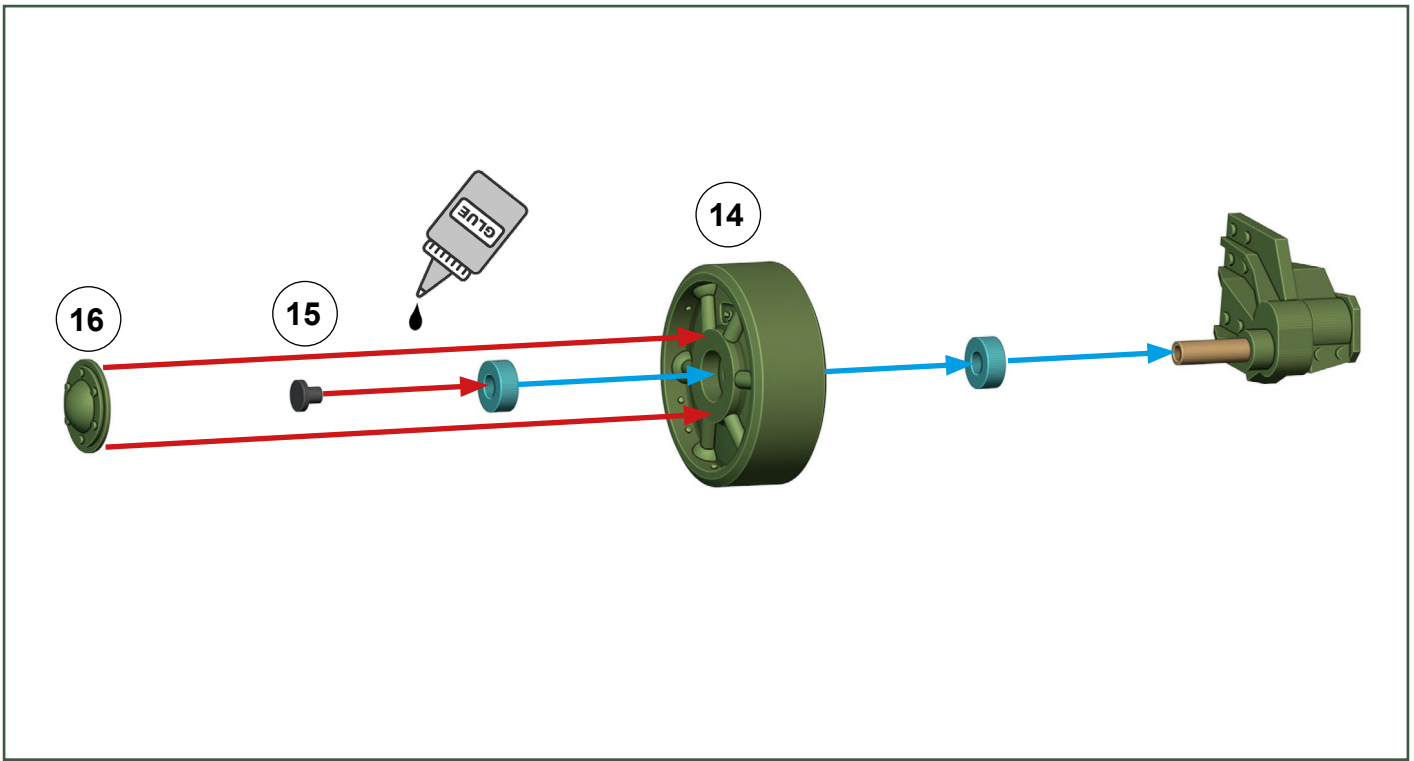

M4A3 Sherman – Build Guide

Tracpcs:

158 pcs (79 pcs for one track)

← use glue
← do not glue

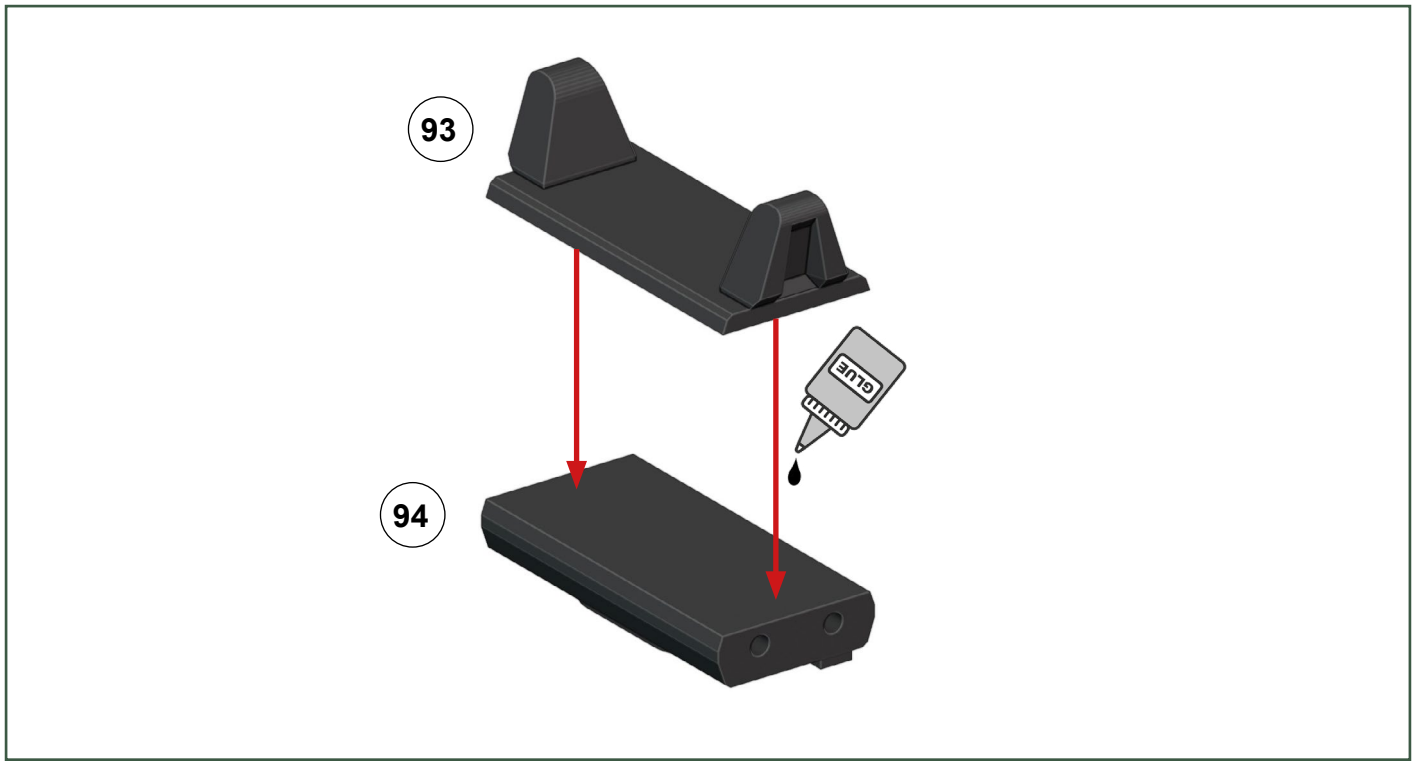

Tracpcs:

2x brass wire 1,5x45 mm

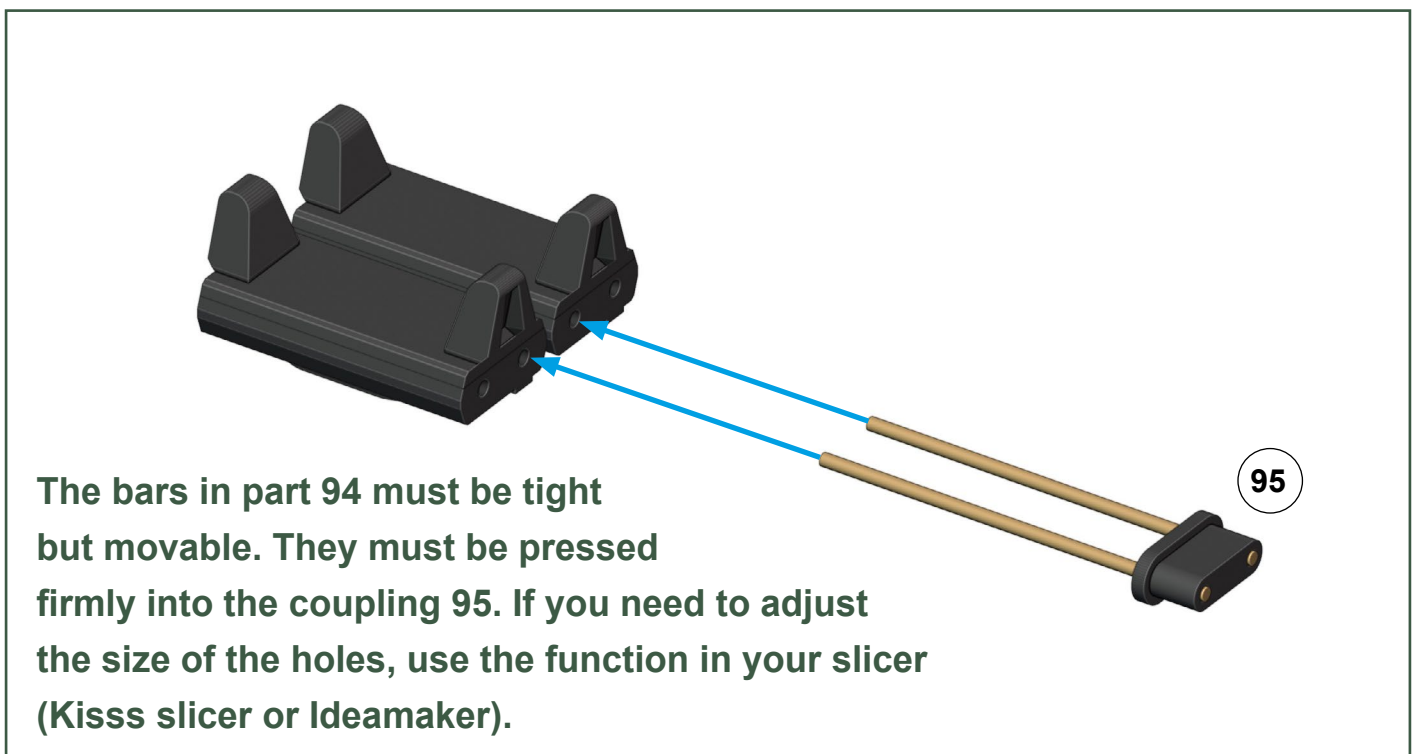

M4A3 Sherman – Build Guide

Tracpcs:

video how to joining the track's parts can be found [here](#). If your slicer cannot adjust the size of the holes, try some variants in the folder “holes variations”.

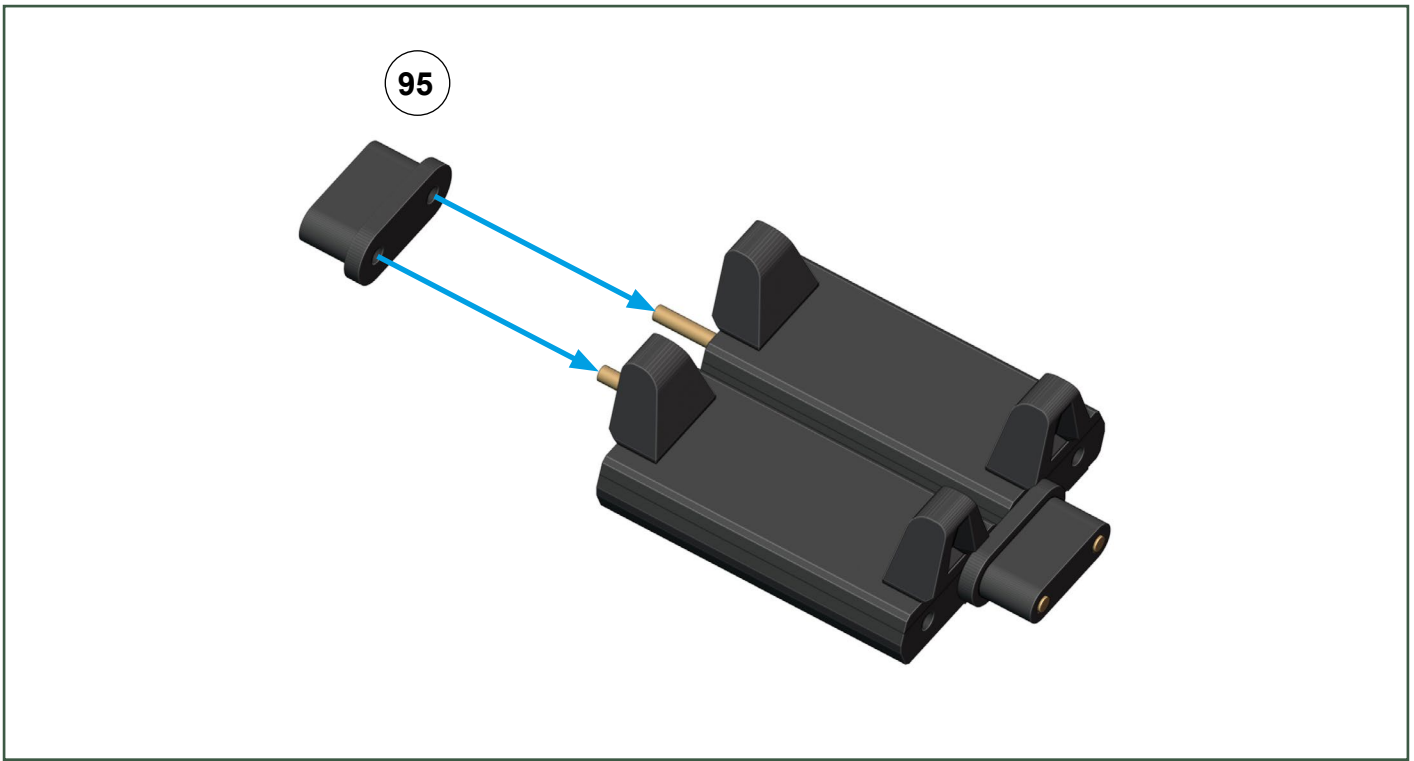

Tracpcs:

Slide the rear wheel assembly into the hull, do not glue yet.

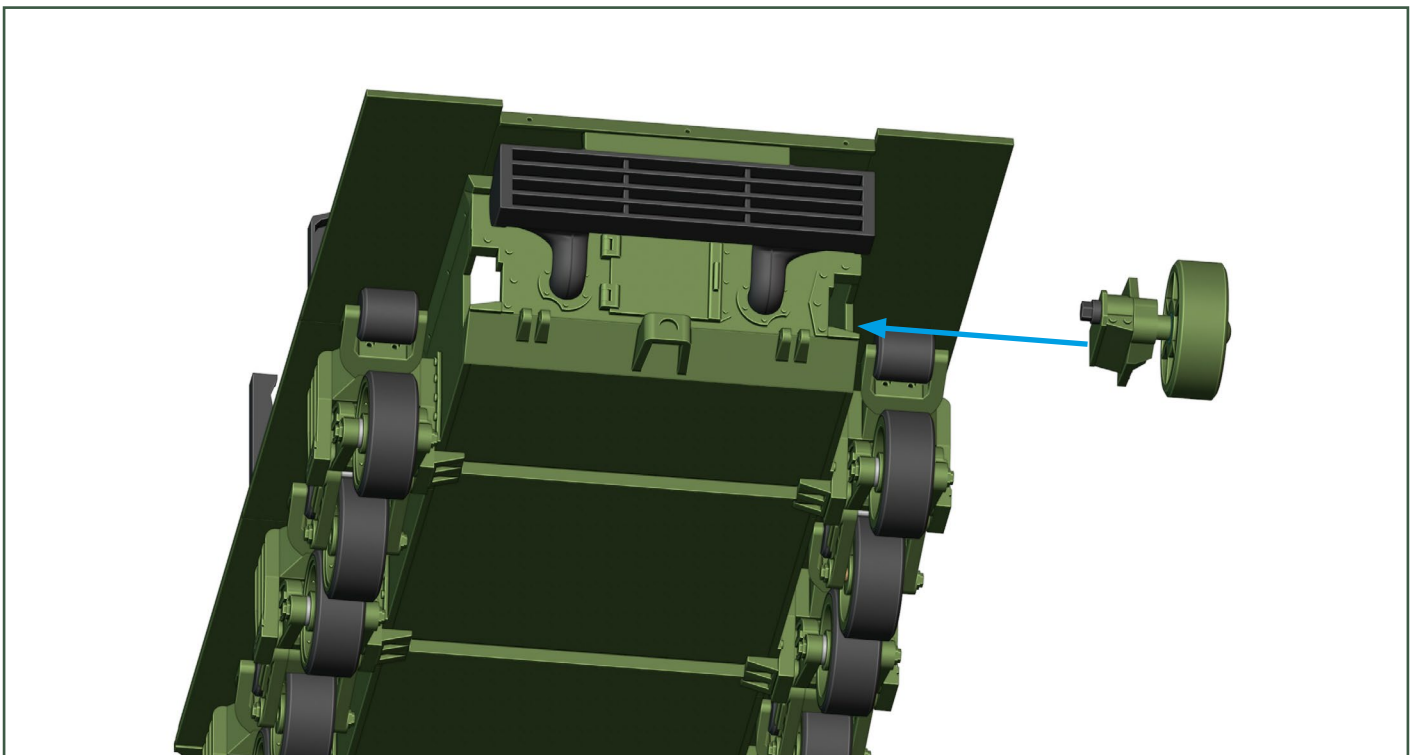

M4A3 Sherman – Build Guide

Tracpcs:

Put on the belt from 79 pieces of parts 94 and close the circuit (so far without the last coupling 95). Move the rear wheel so that the belt is slightly taut and mark its position with a line on the side of the hull.

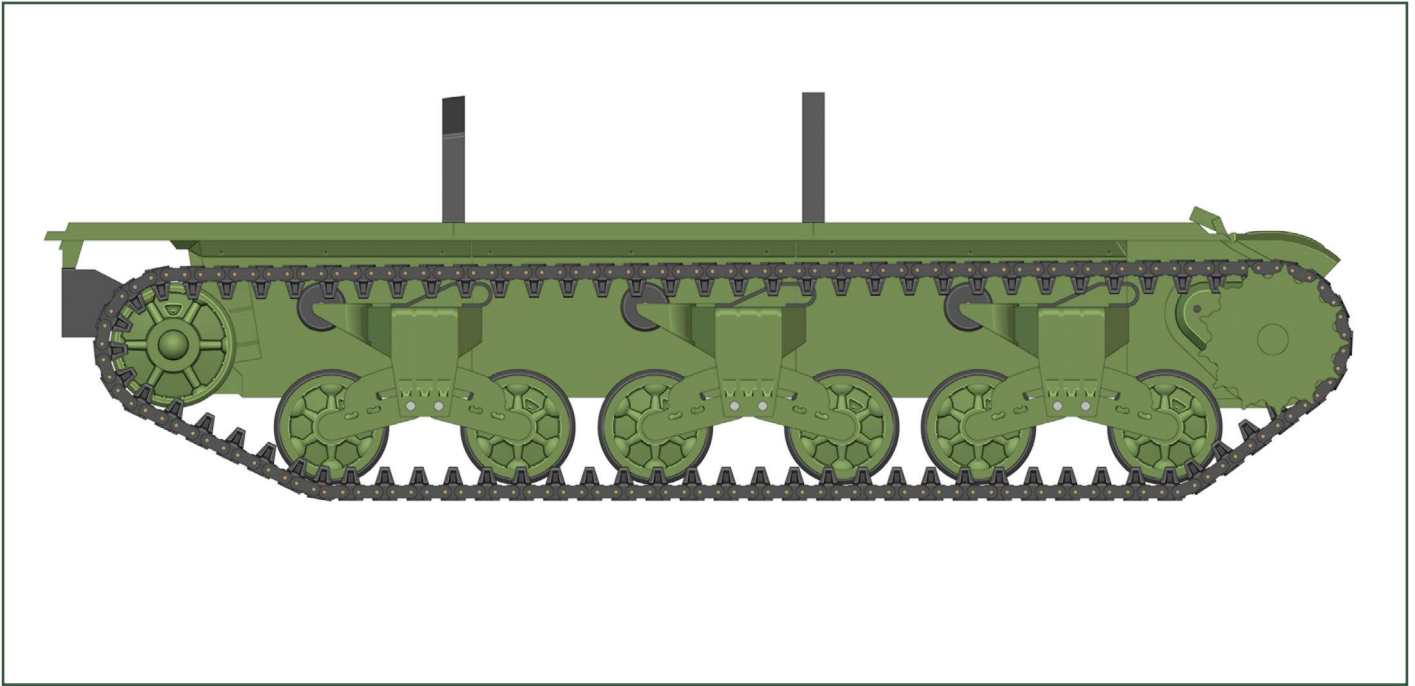

Tracpcs:

Remove the tracks, and glue the rear wheel assembly to the marked location. After glue has dried thoroughly, put on the tracks and close it with jumpers 95 on both sides. Put the tracks on the other side in the same way. Connect the electronics and test the function of the tracks.

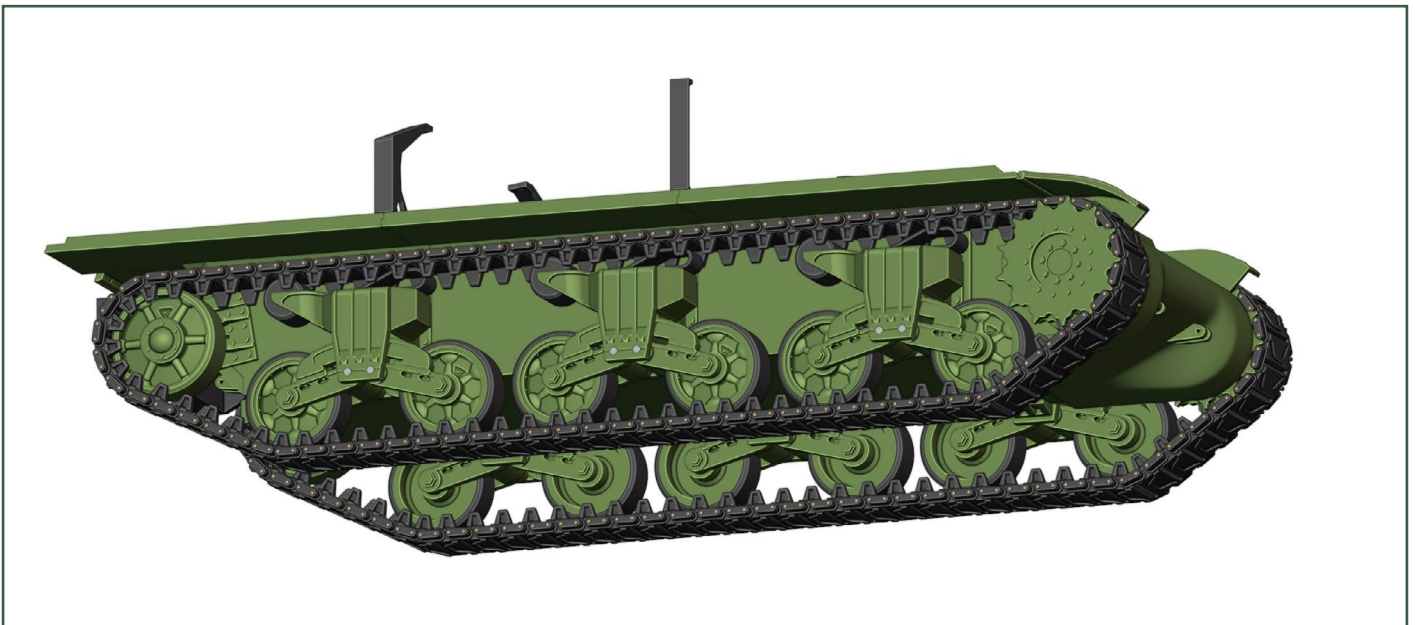

M4A3 Sherman - Build Guide

Upper hull:

2x M2 screw 6 mm, M2 screw 10 mm

STL files marked "clear" are without graphics.

← use glue

← do not glue

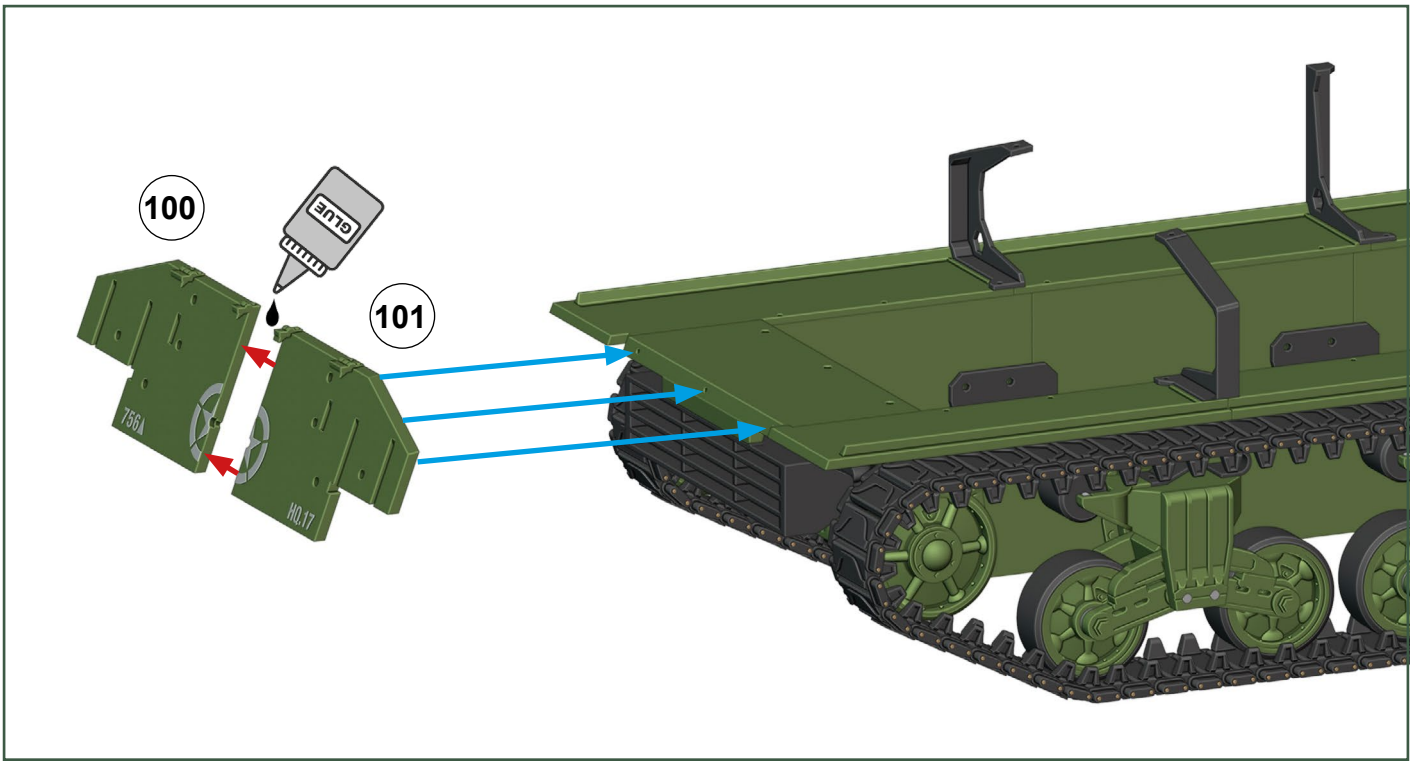

Upper hull:

4x M2 screw 6 mm

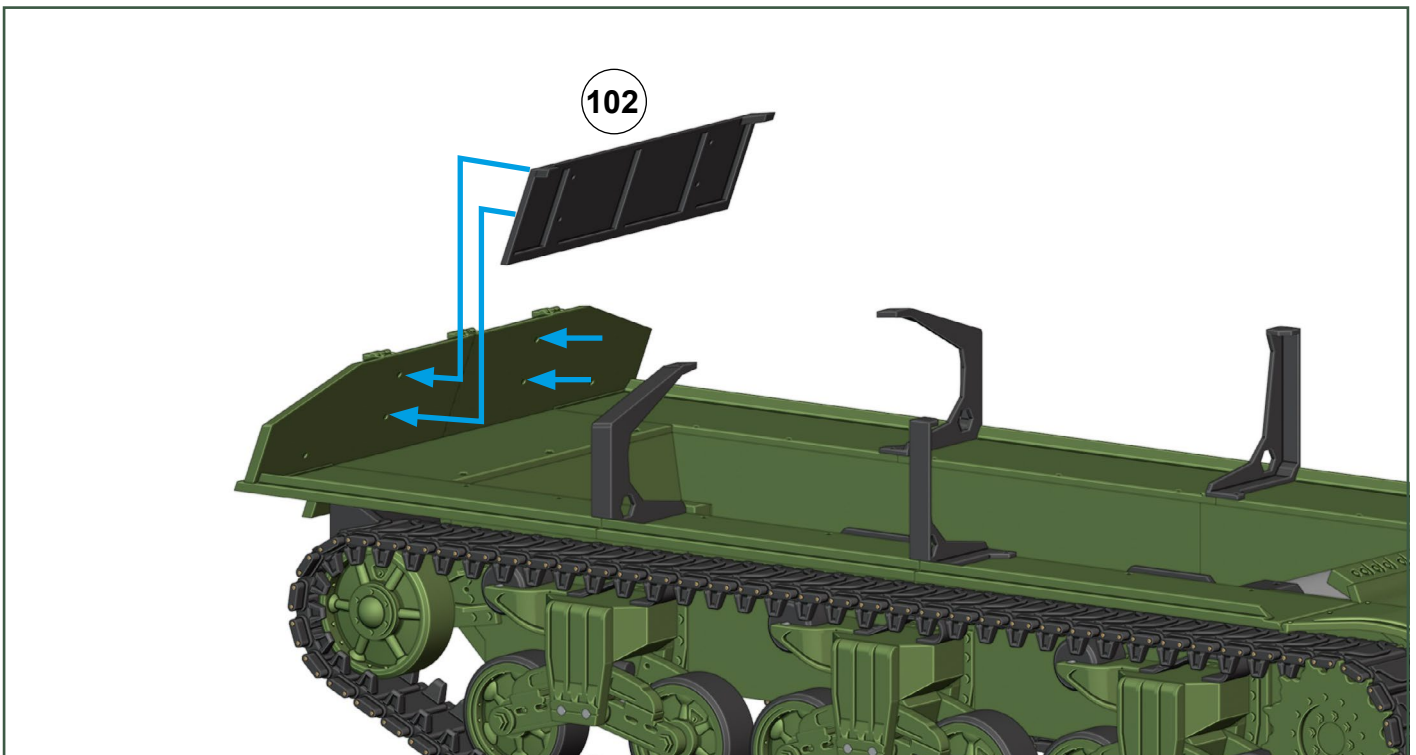

M4A3 Sherman – Build Guide

Upper hull:

2x M2 screw 6 mm

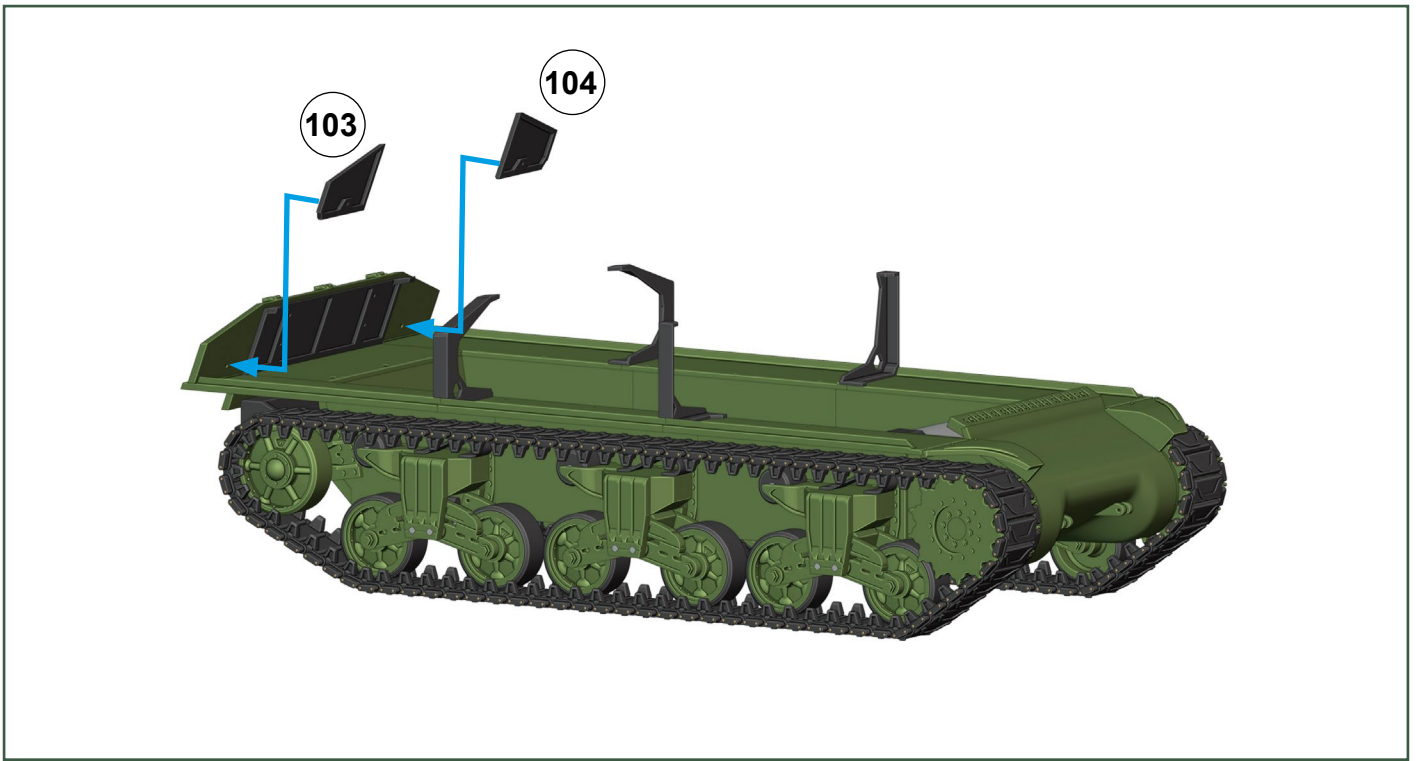

Upper hull:

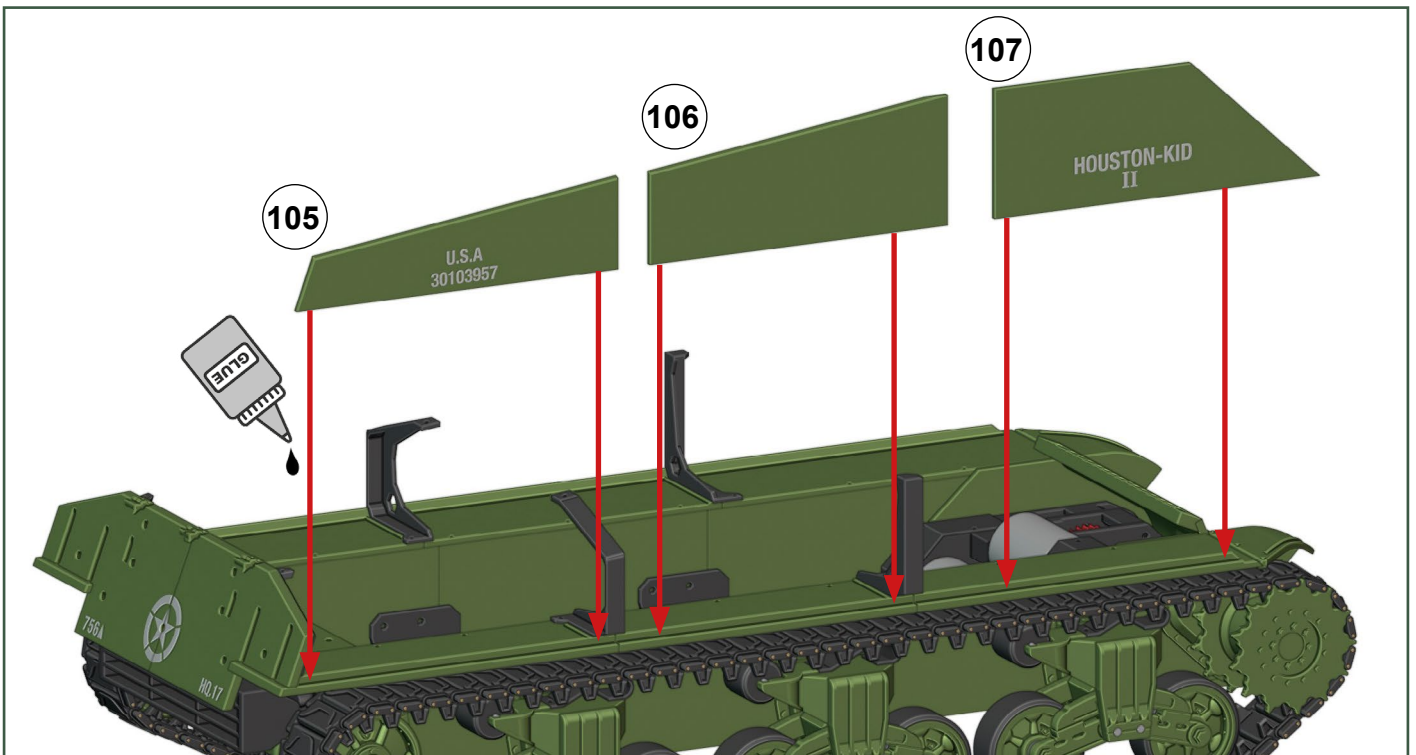

M4A3 Sherman – Build Guide

Upper hull:

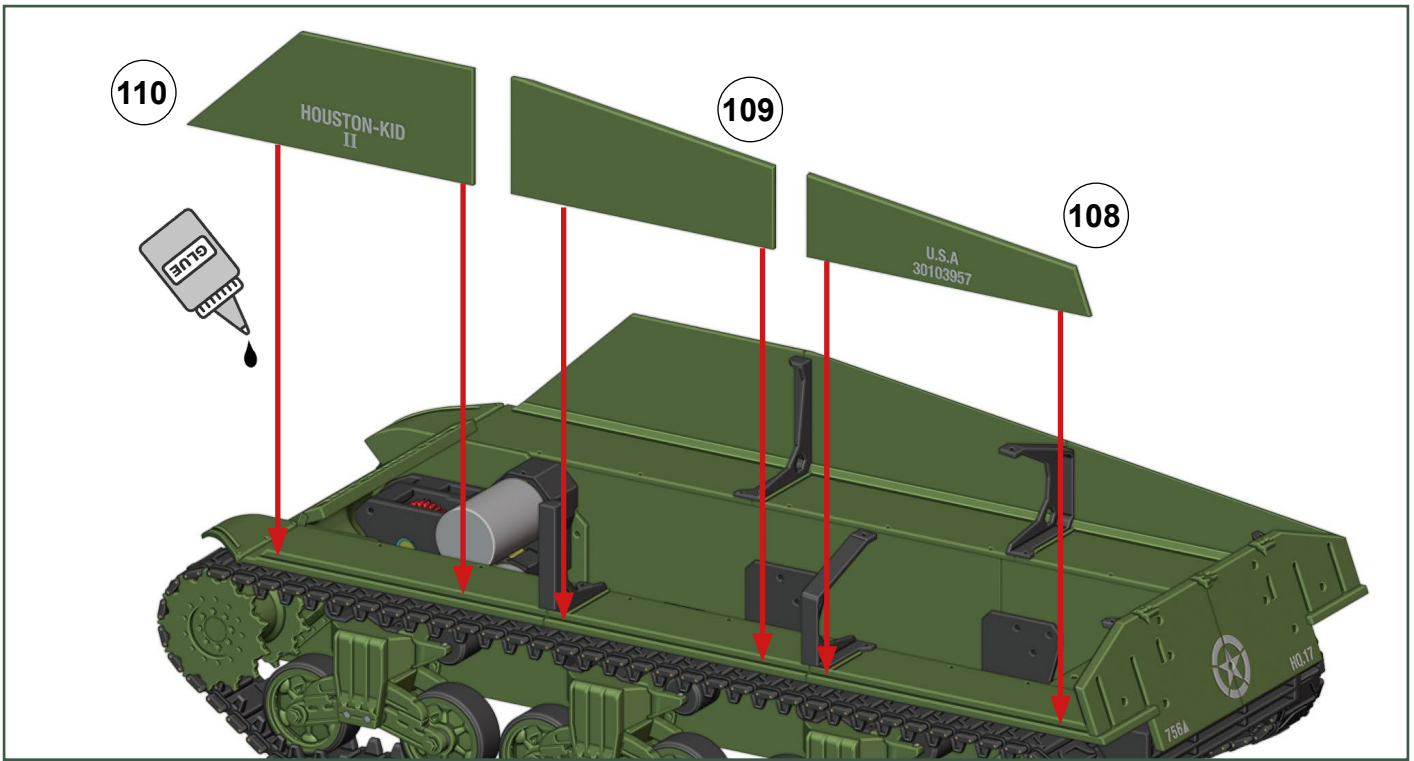

Upper hull:

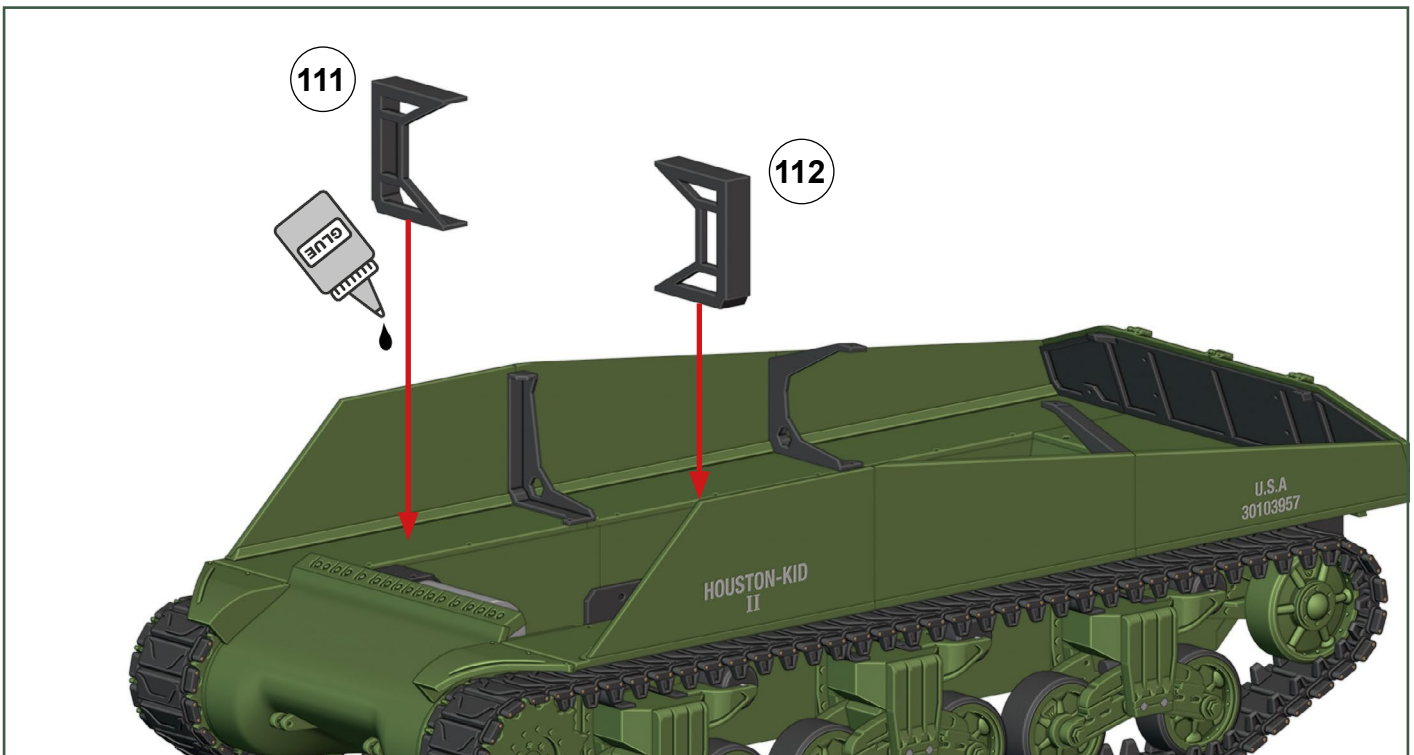

M4A3 Sherman - Build Guide

Upper hull:

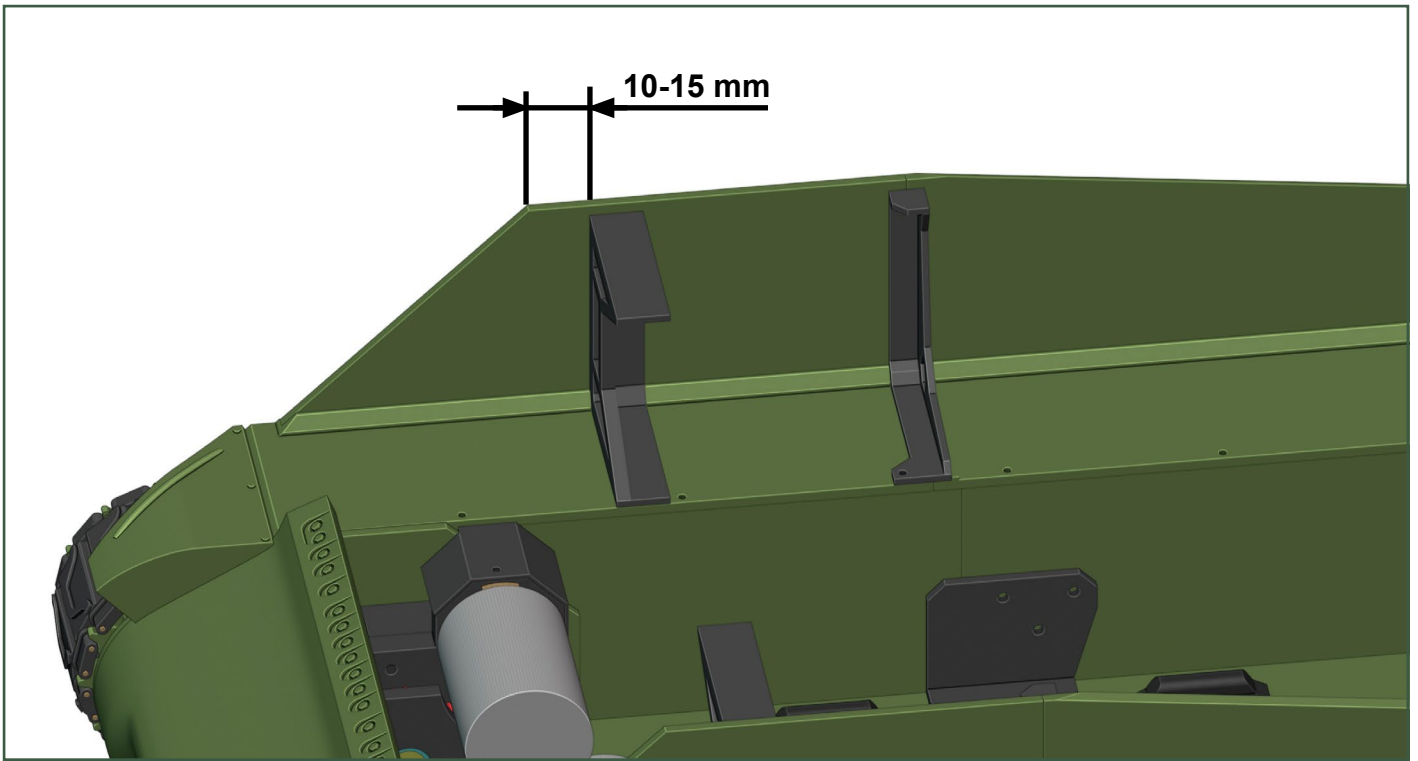

Upper hull:

2x M2 screw 8 mm

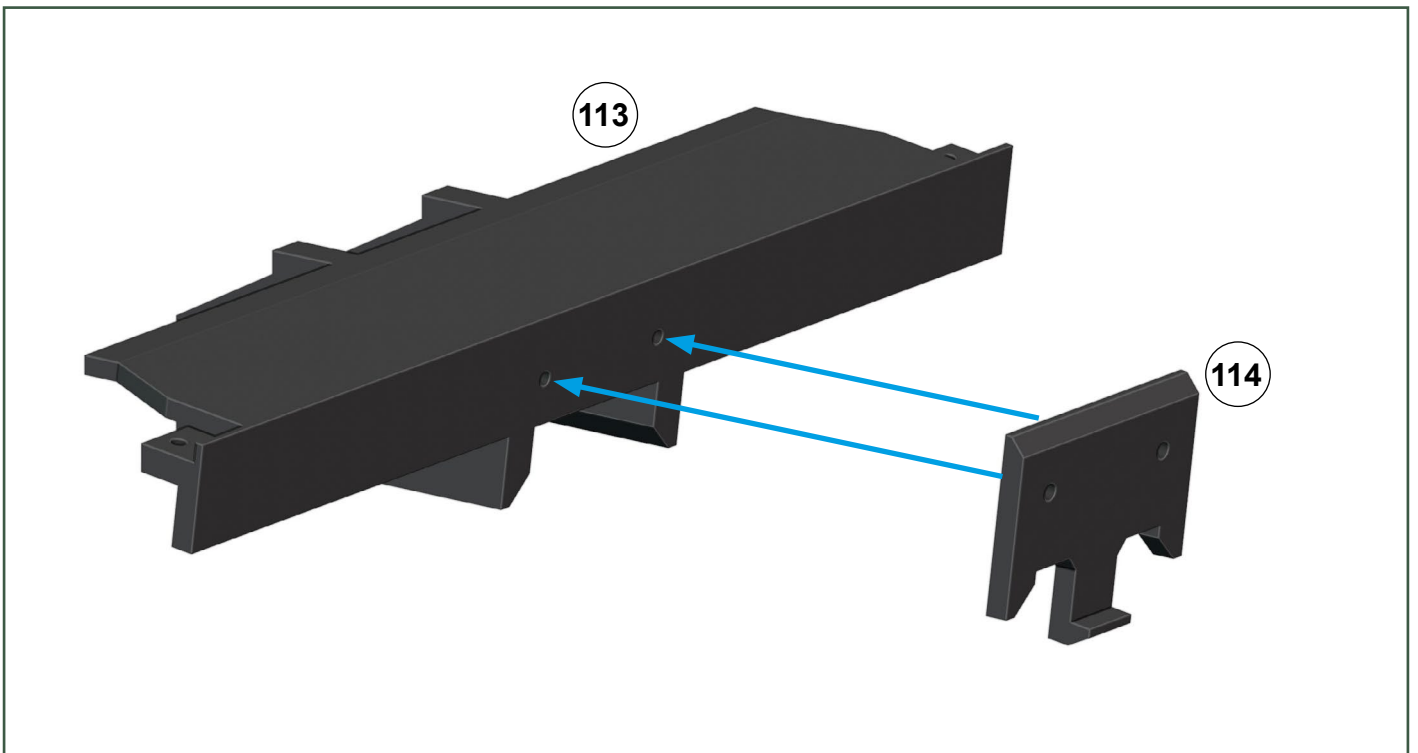

M4A3 Sherman – Build Guide

Upper hull:

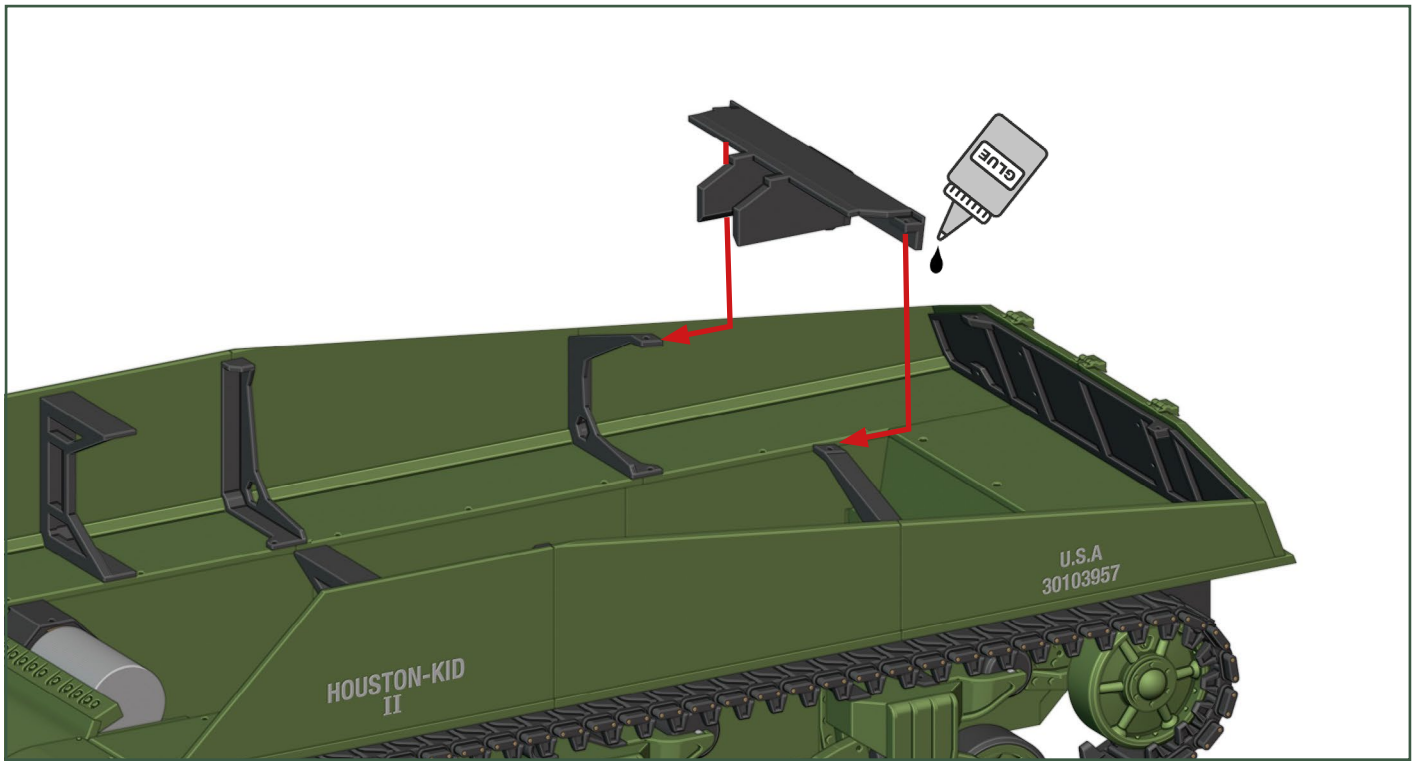

Upper hull:

2x M2 screw 8 mm (front), 2x M2 screw 6 mm (rear)

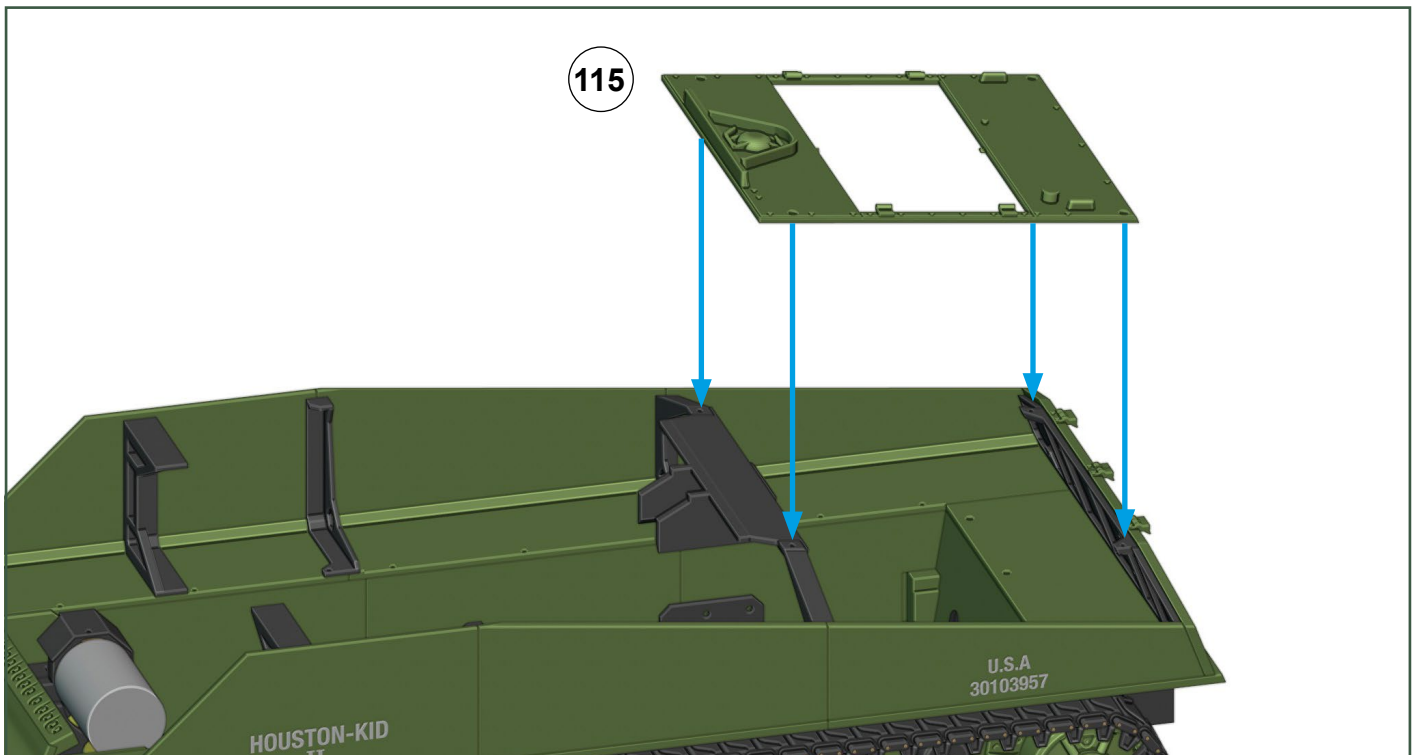

M4A3 Sherman – Build Guide

Upper hull:

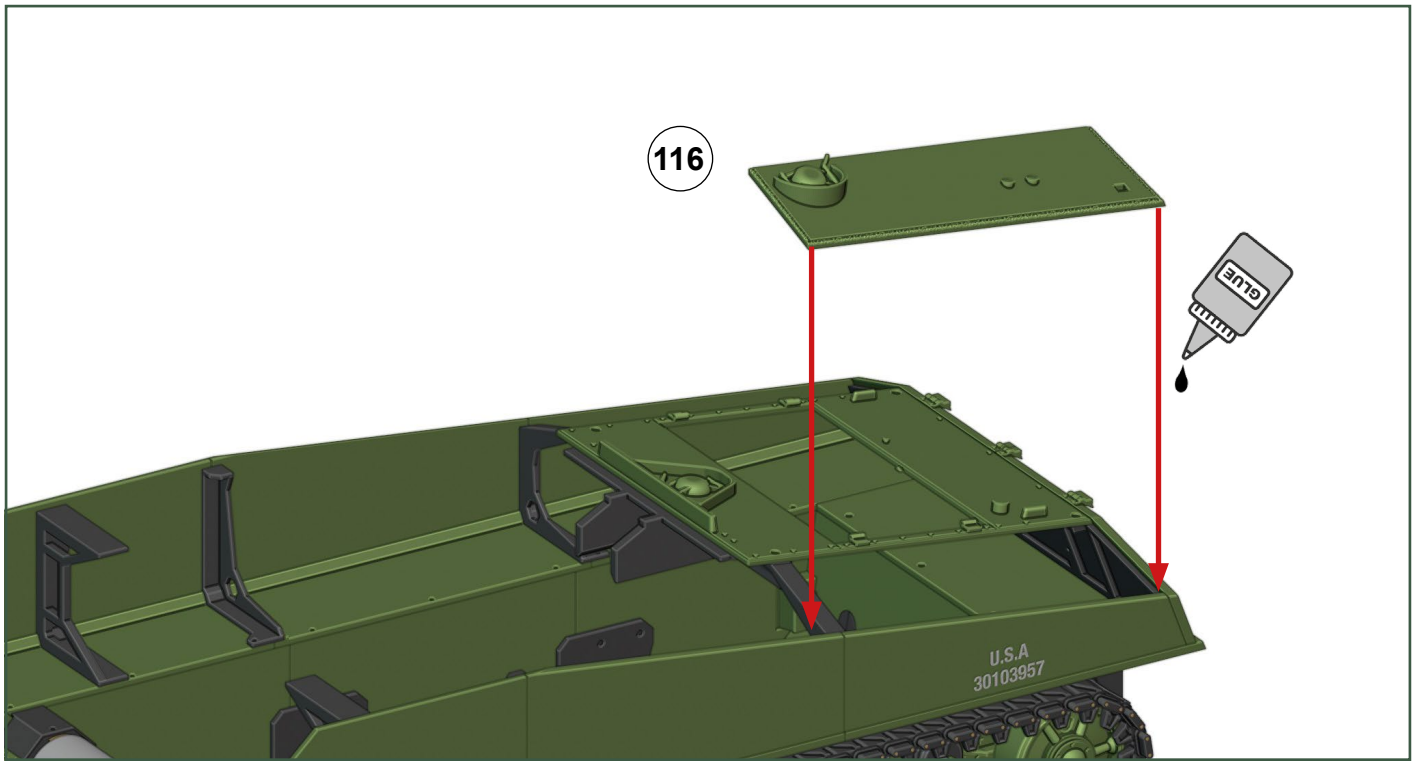

Upper hull:

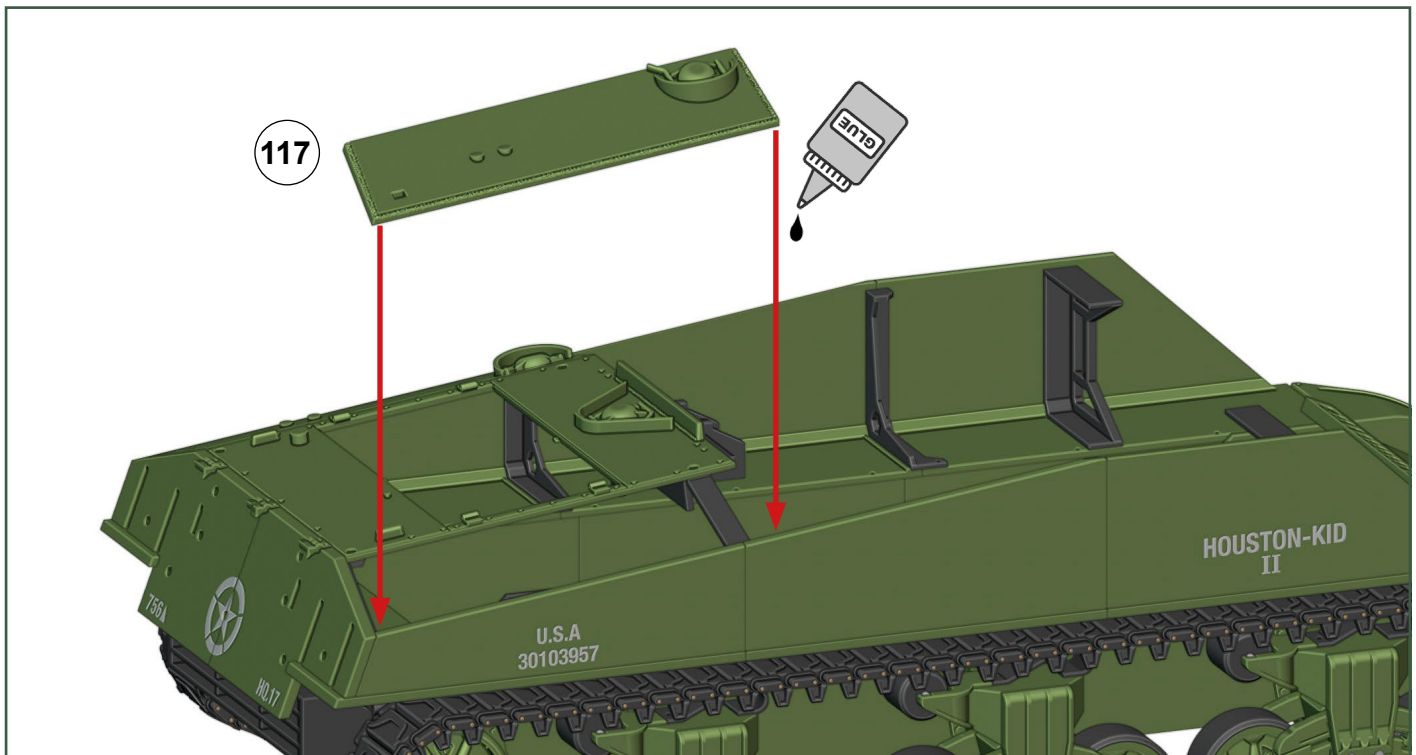

M4A3 Sherman - Build Guide

Upper hull:

4x wire 1,2x15 mm

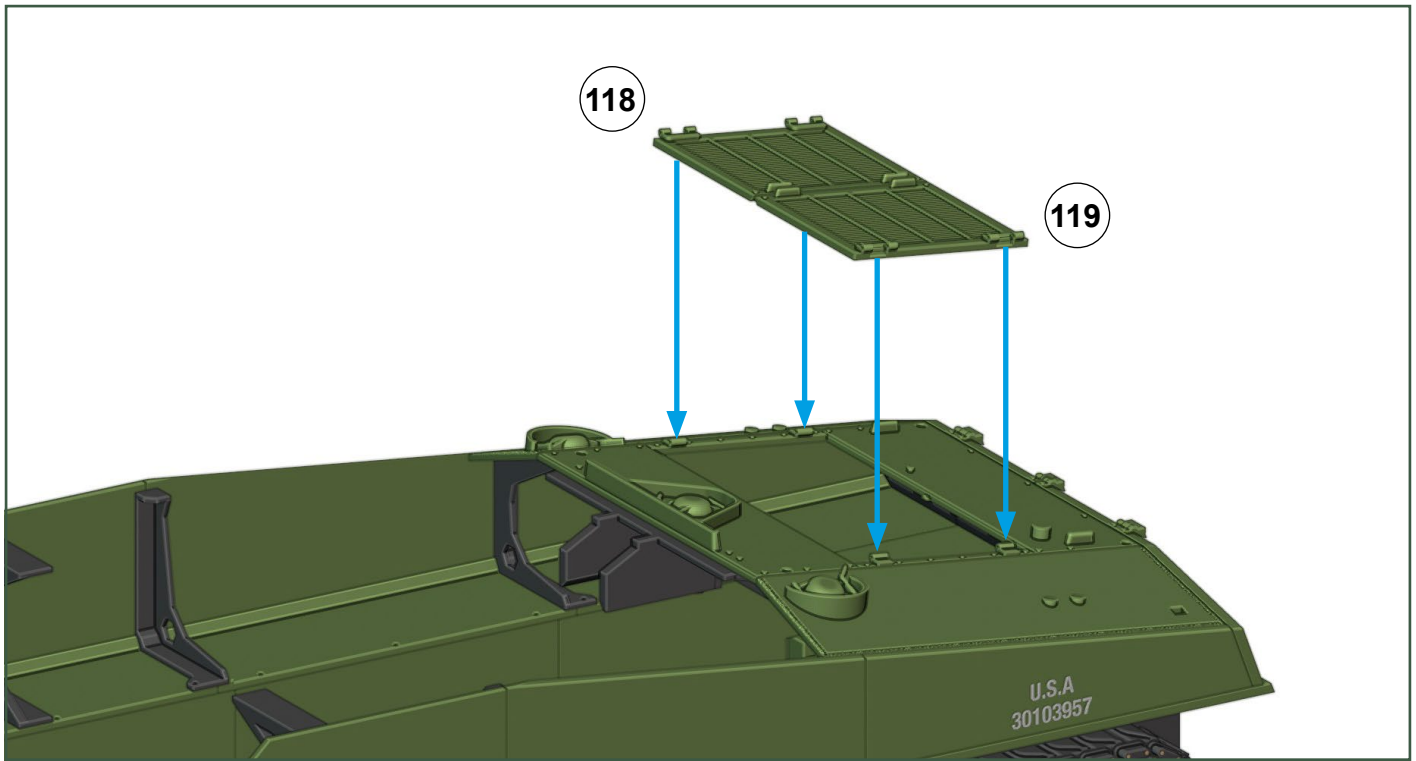

Upper hull:

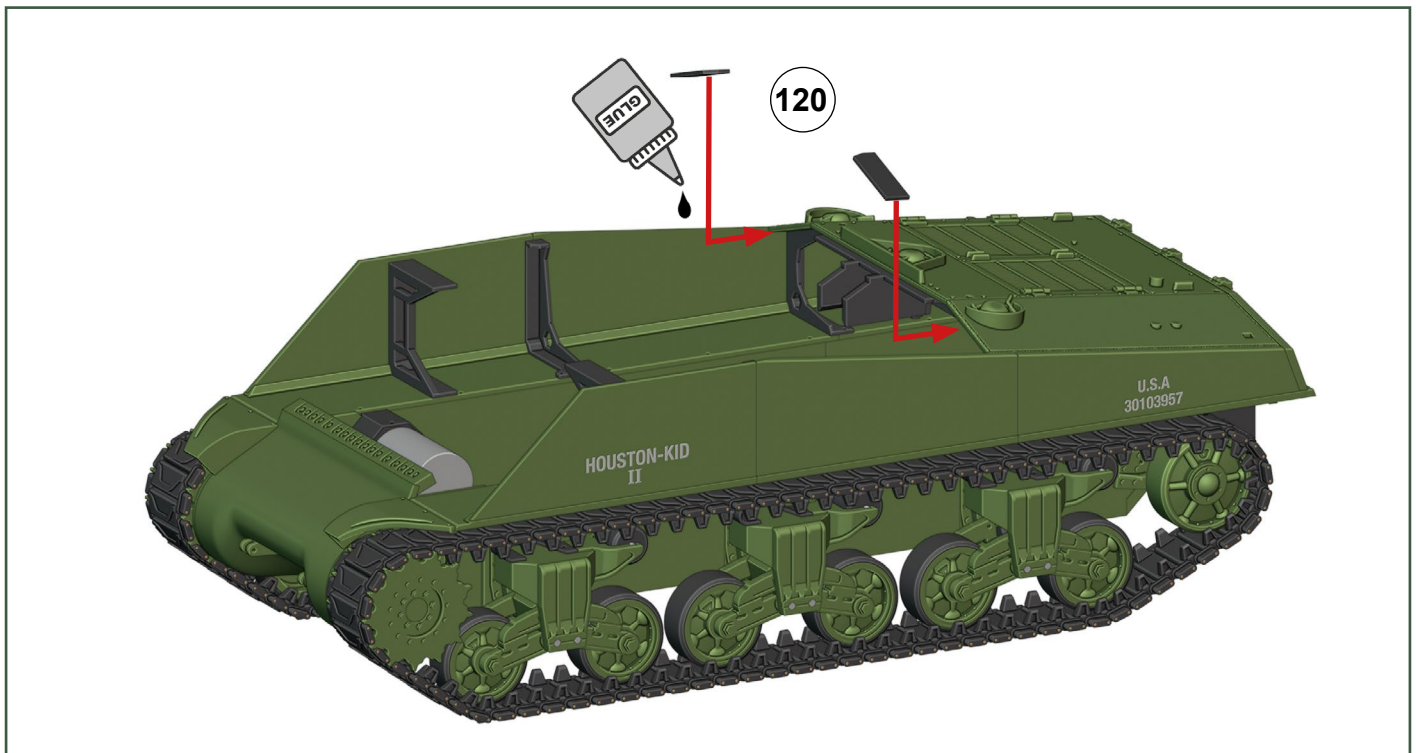

M4A3 Sherman - Build Guide

Upper hull:

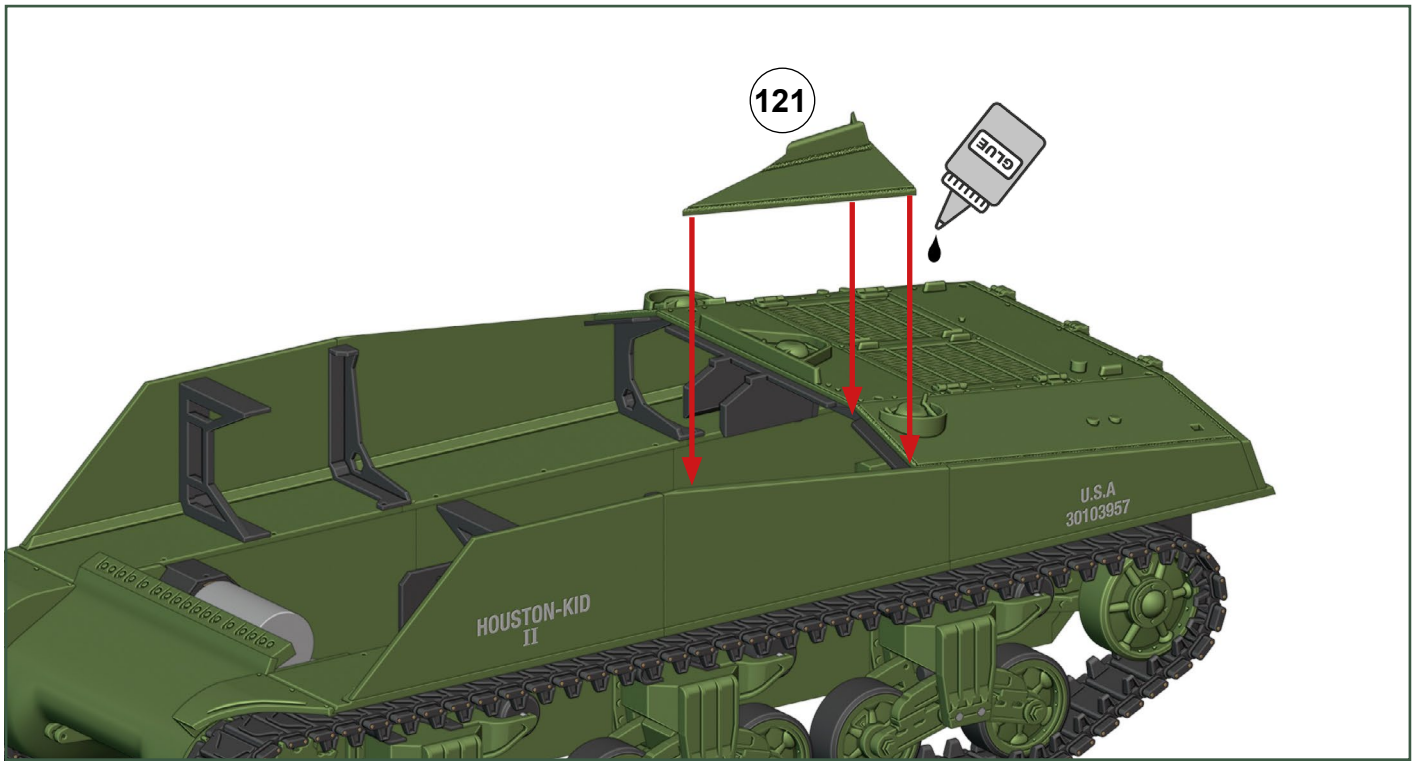

Upper hull:

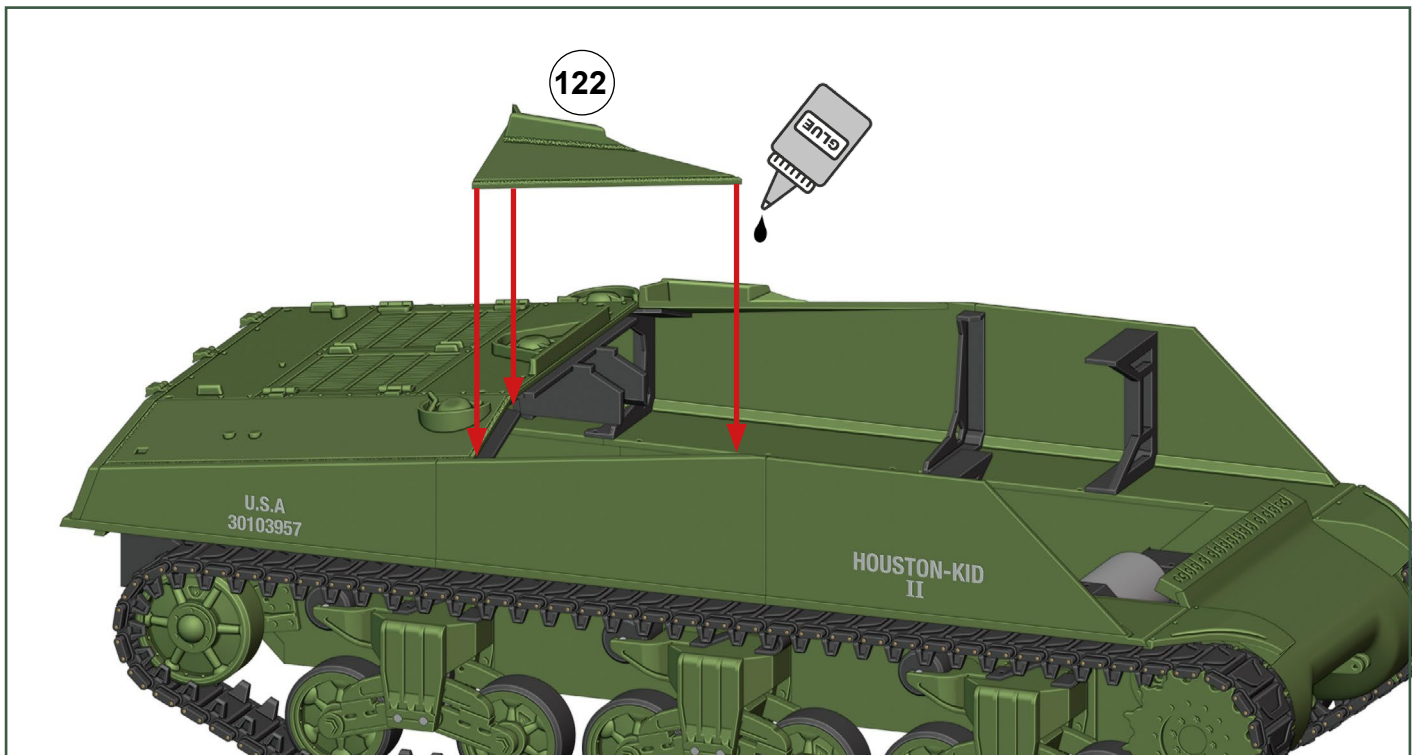

M4A3 Sherman – Build Guide

Upper hull:

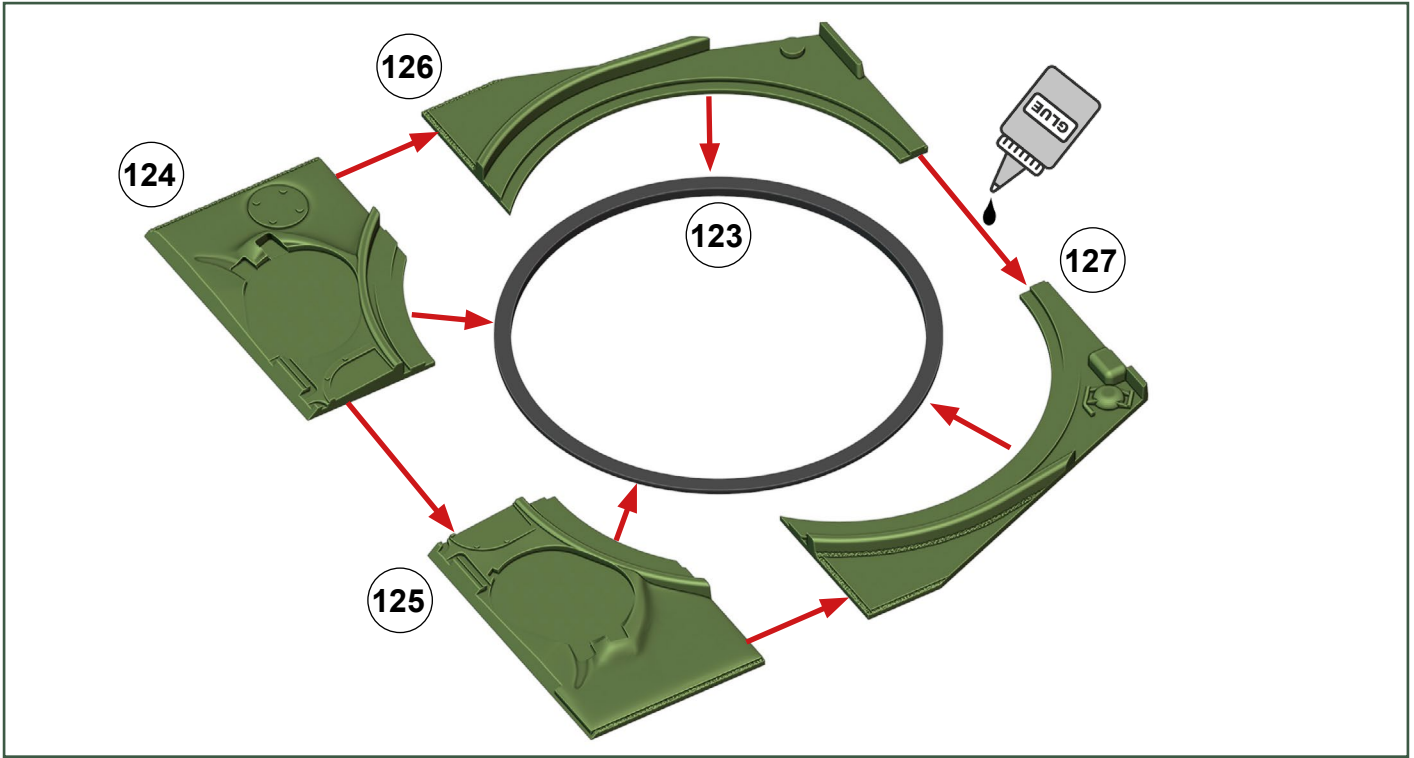

Upper hull:

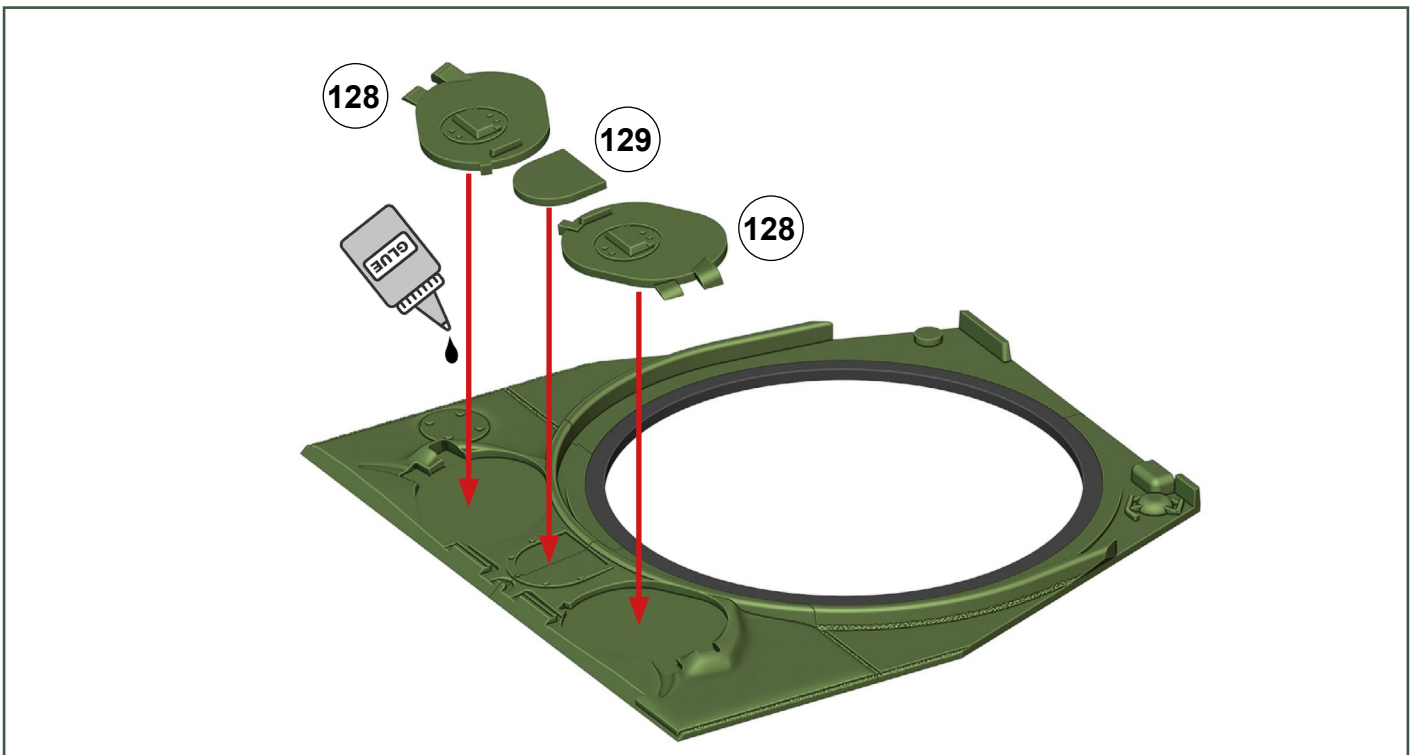

M4A3 Sherman - Build Guide

Upper hull:

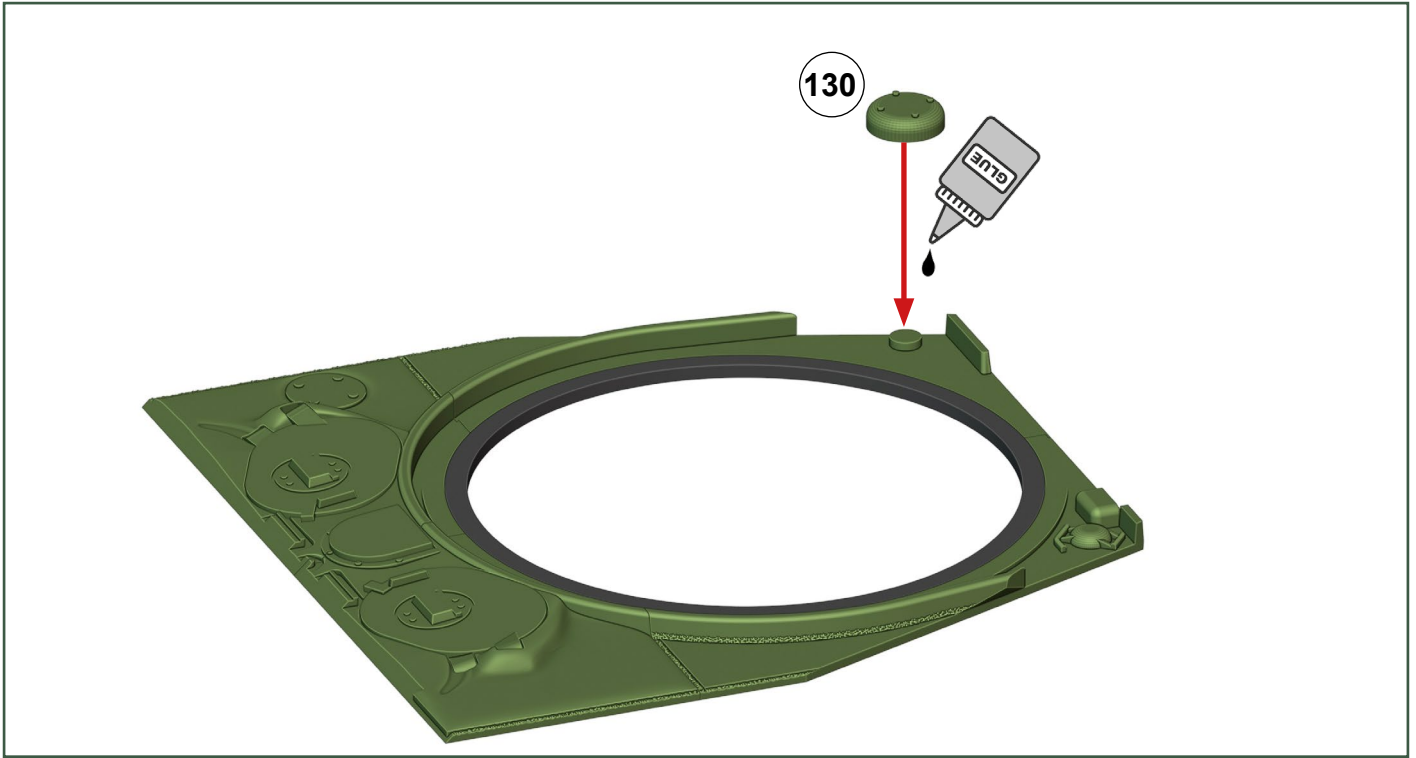

Upper hull:

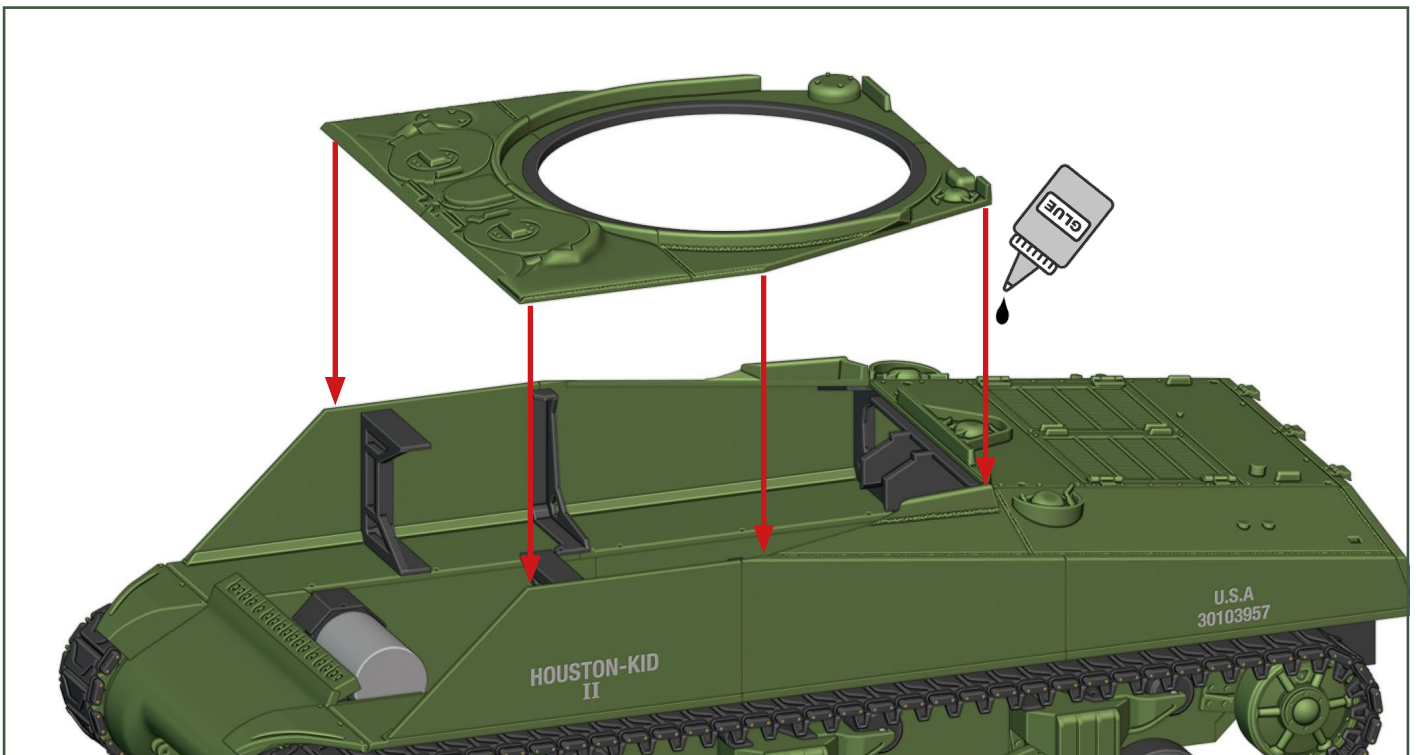

M4A3 Sherman - Build Guide

Upper hull:

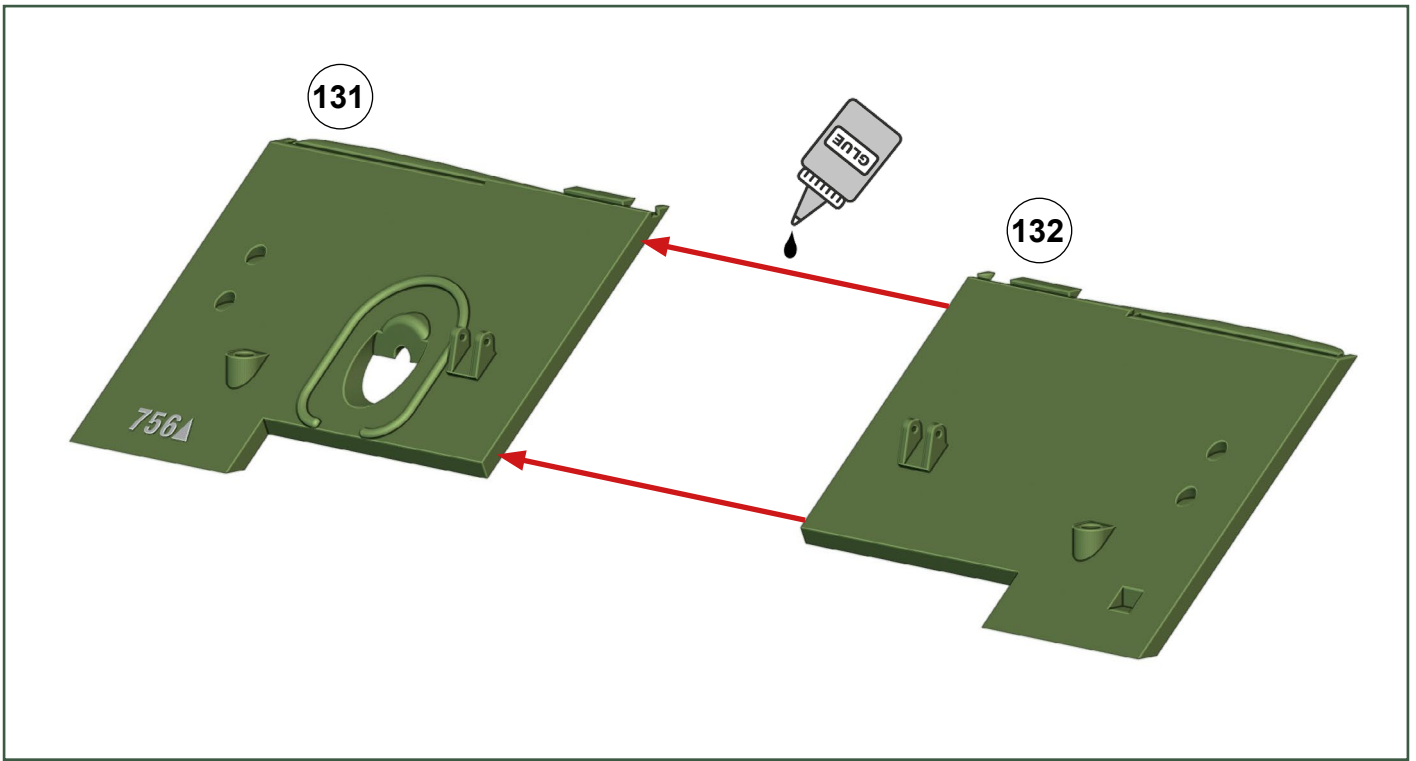

Upper hull:

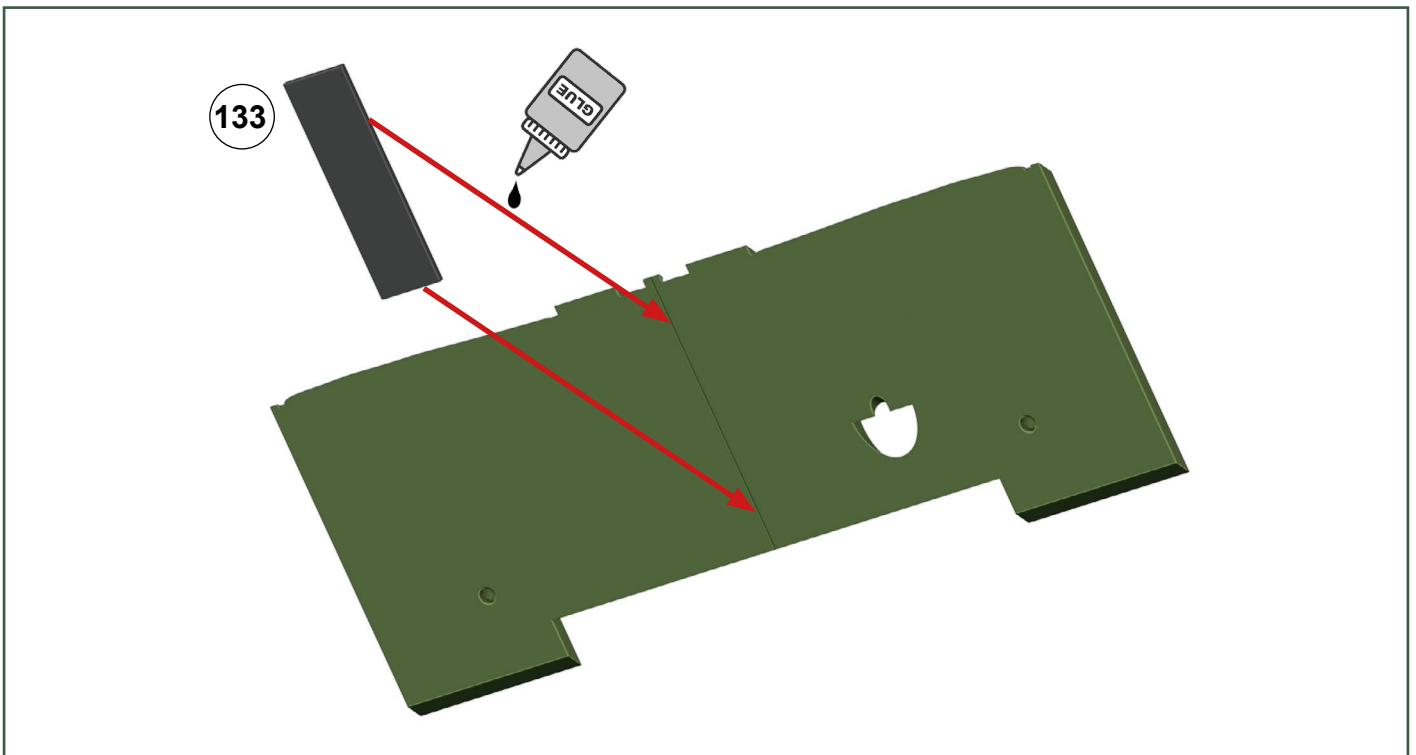

M4A3 Sherman - Build Guide

Upper hull:

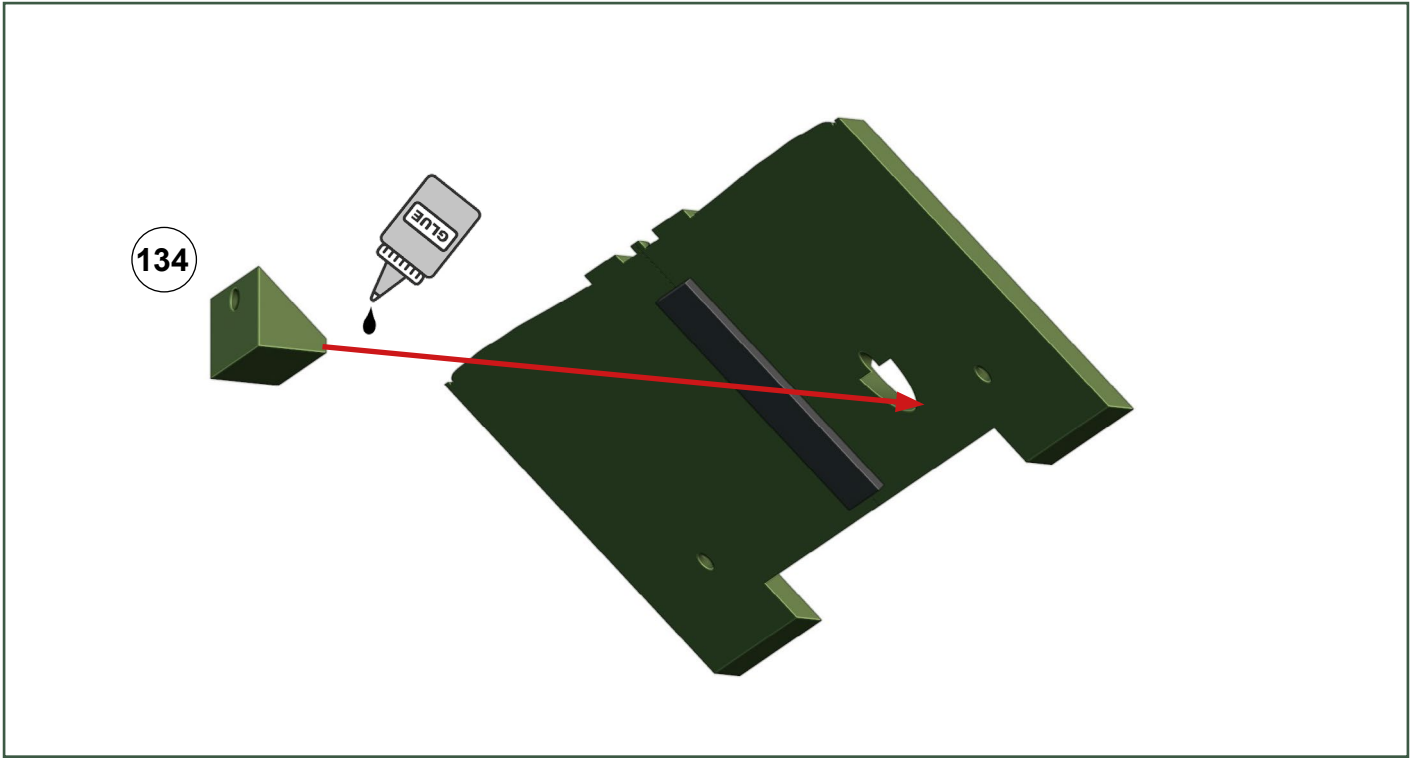

Upper hull:

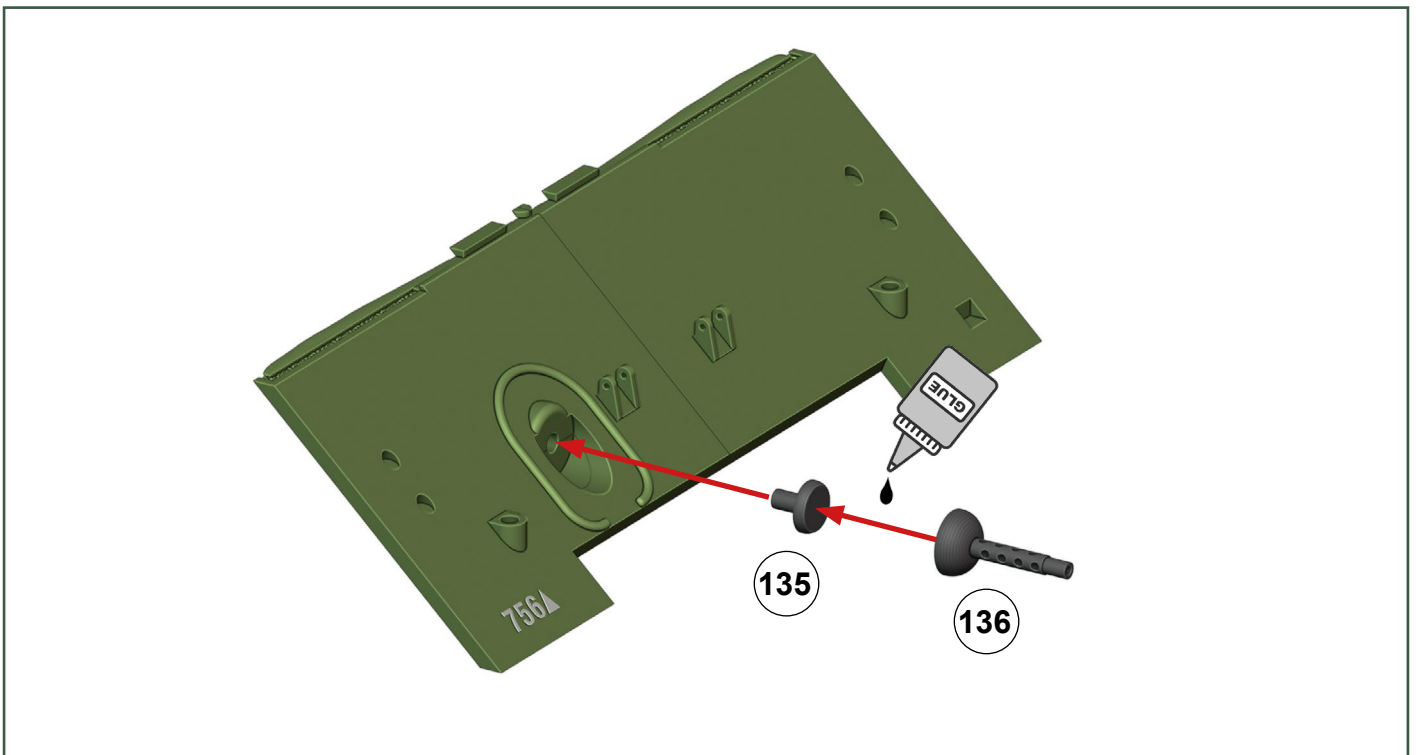

M4A3 Sherman – Build Guide

Upper hull:

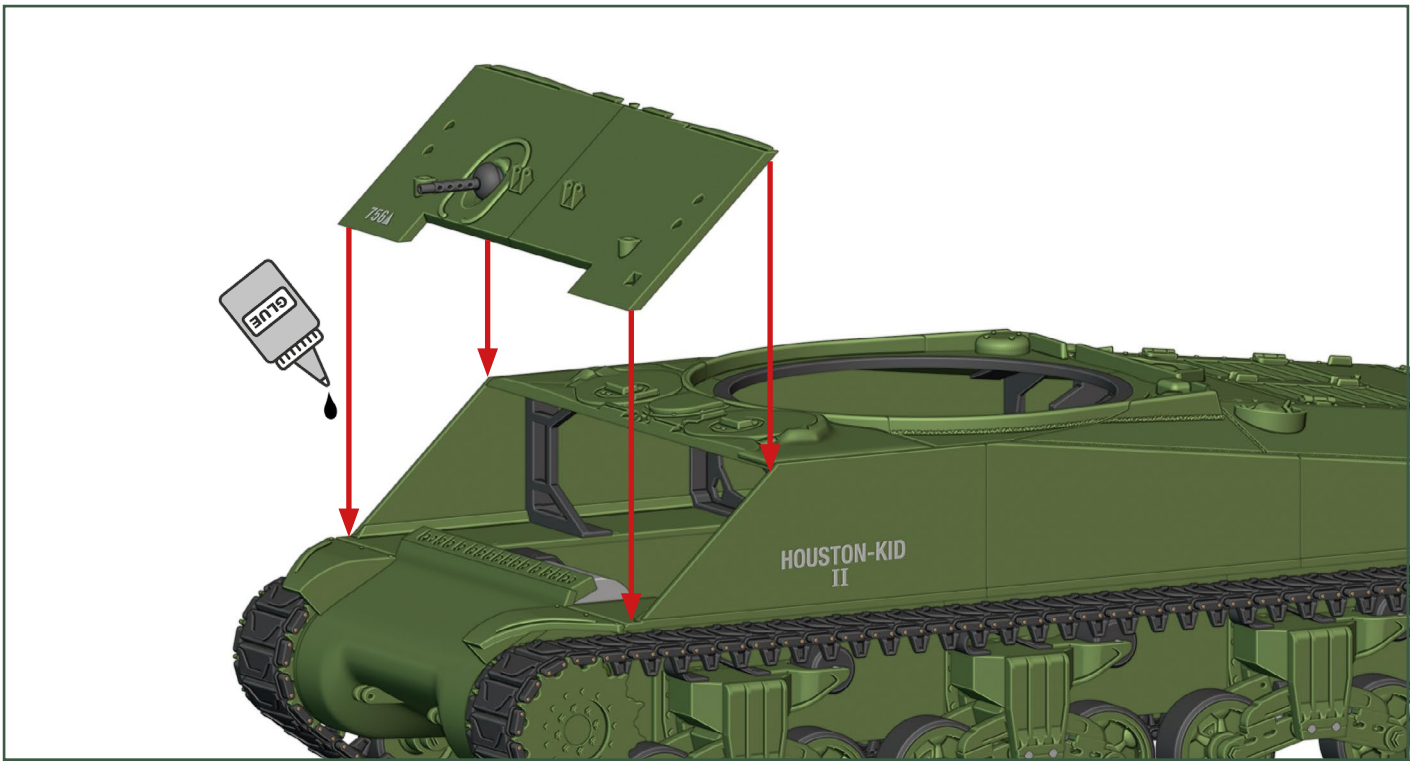

Upper hull:

2x wire 1,2x10 mm

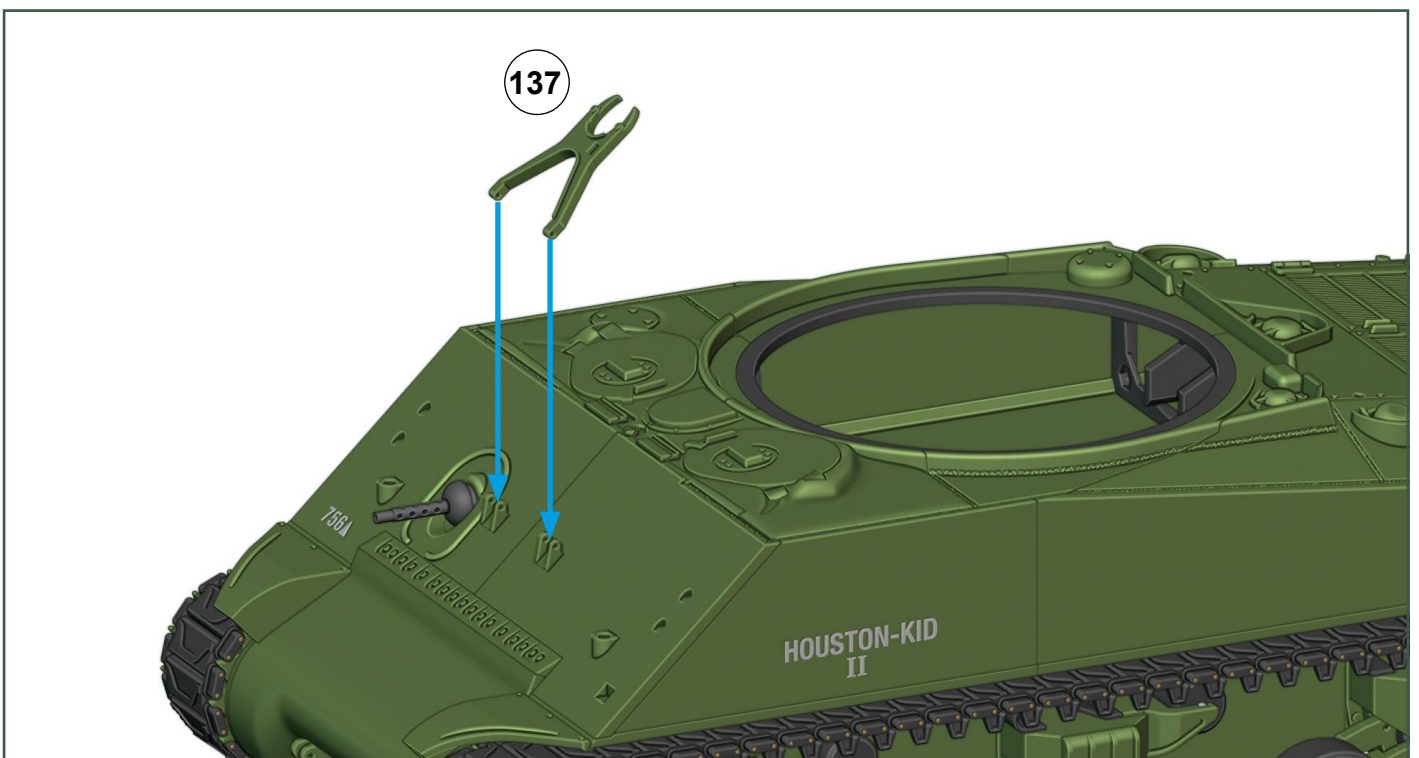

M4A3 Sherman - Build Guide

Upper hull:

2x

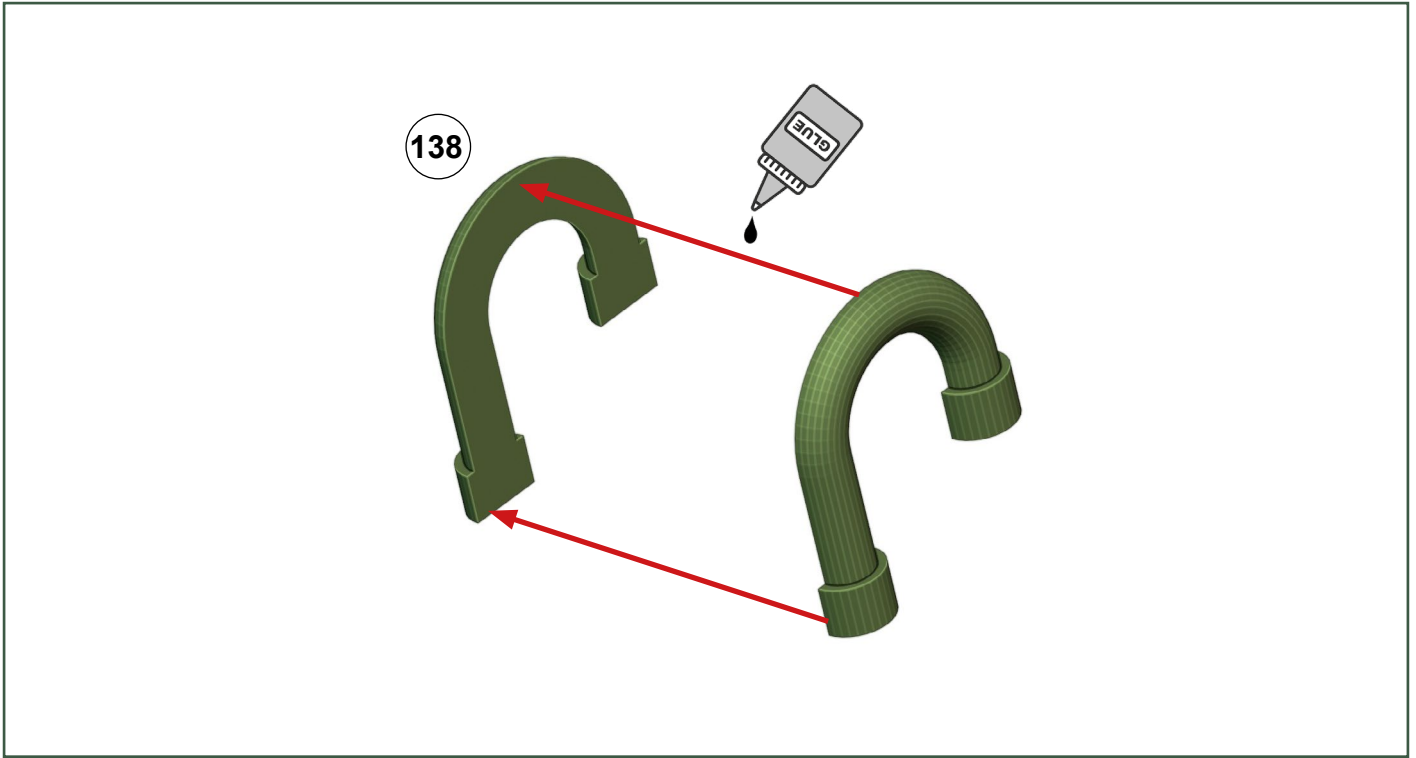

Upper hull:

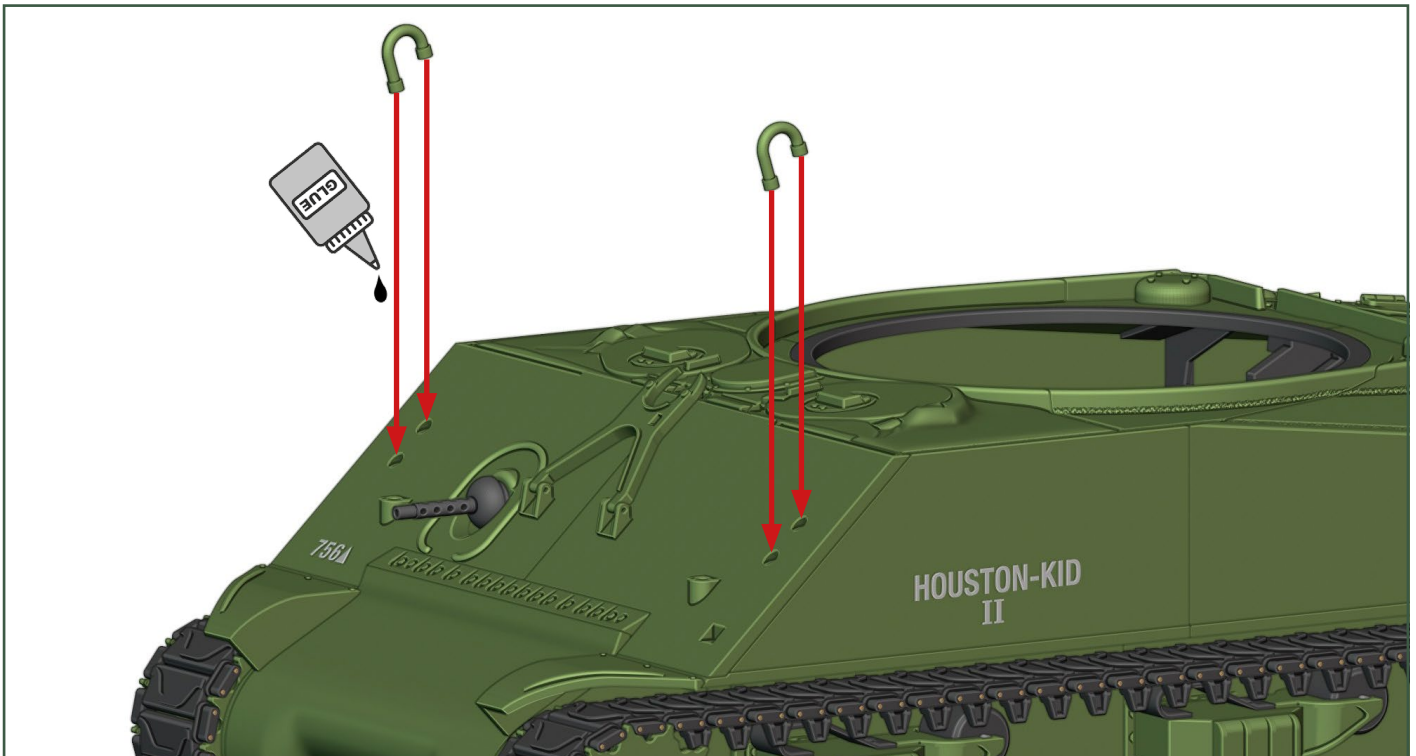

M4A3 Sherman – Build Guide

Upper hull:

2x

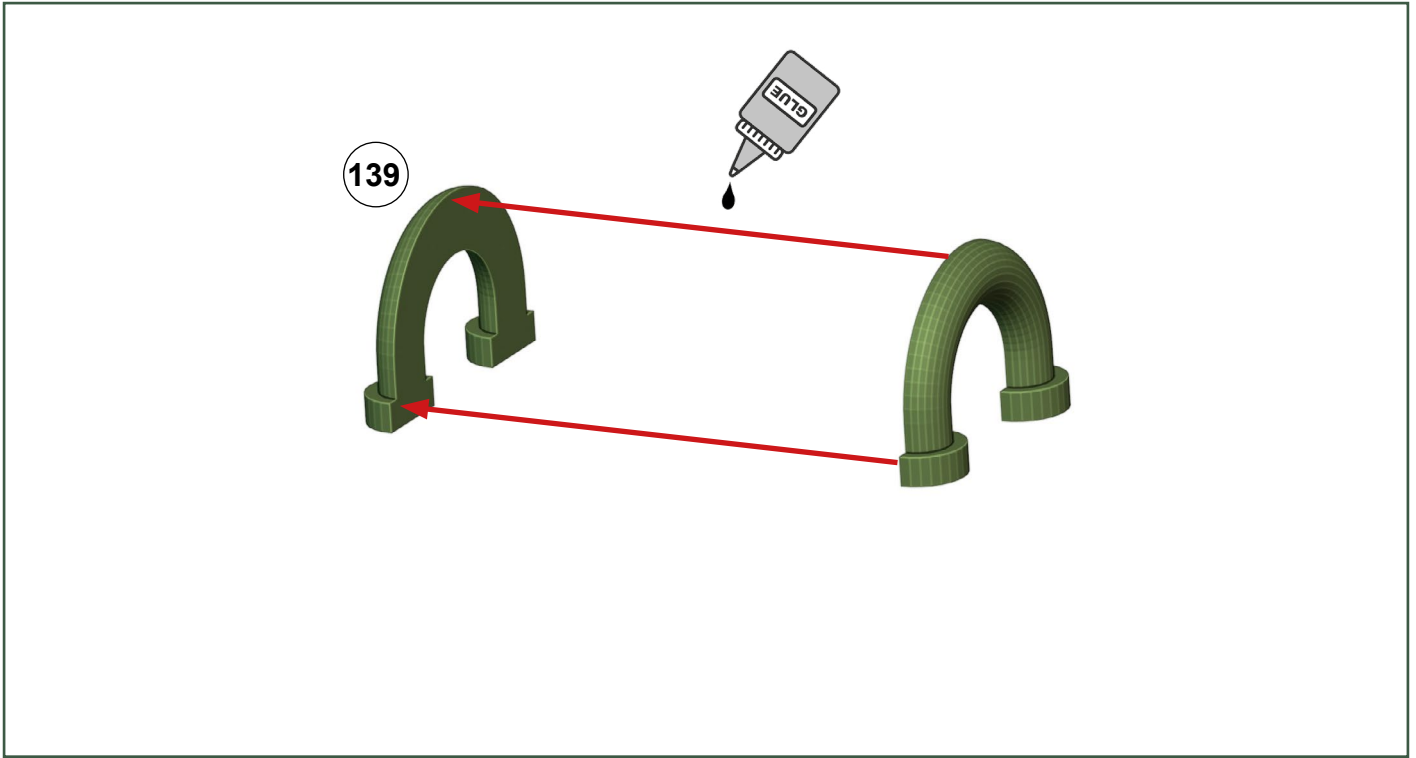

Upper hull:

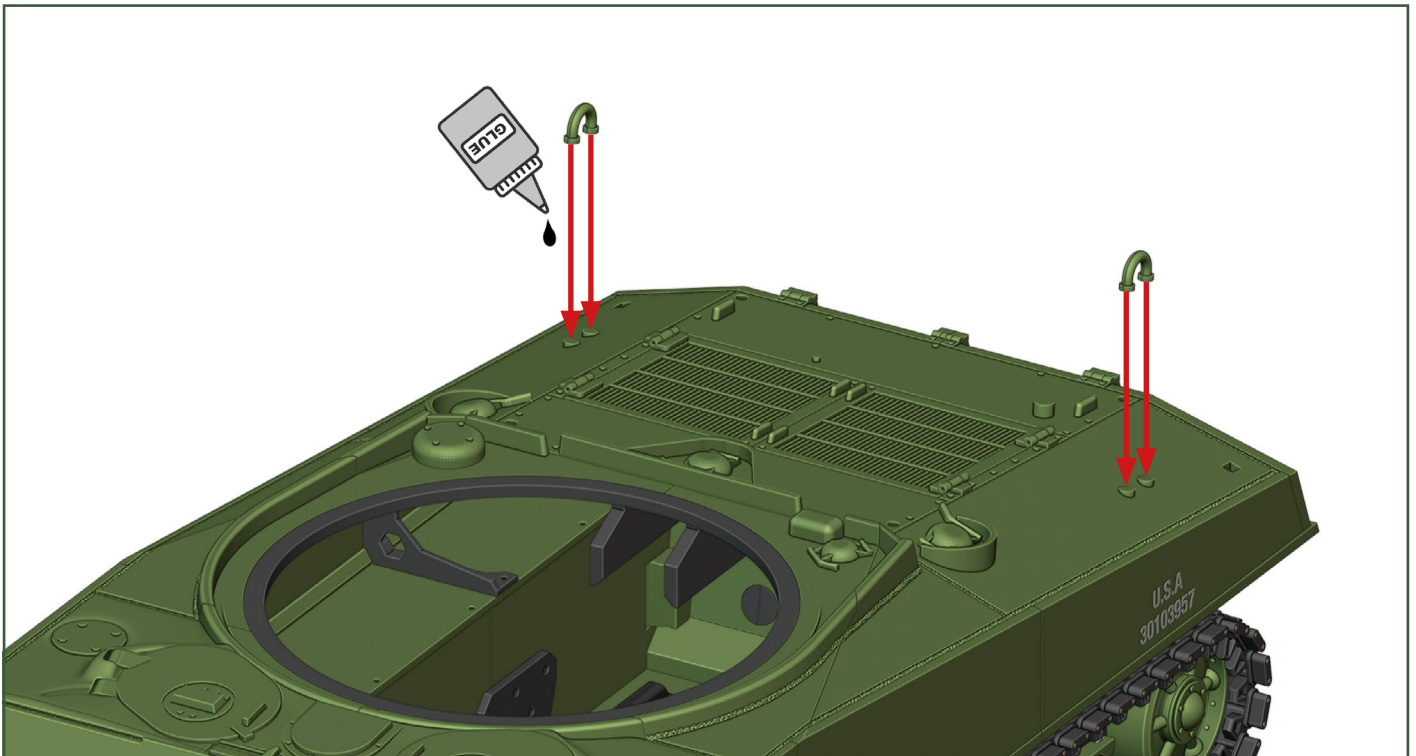

M4A3 Sherman - Build Guide

Upper hull:

2x M2 screw 10 mm with washer

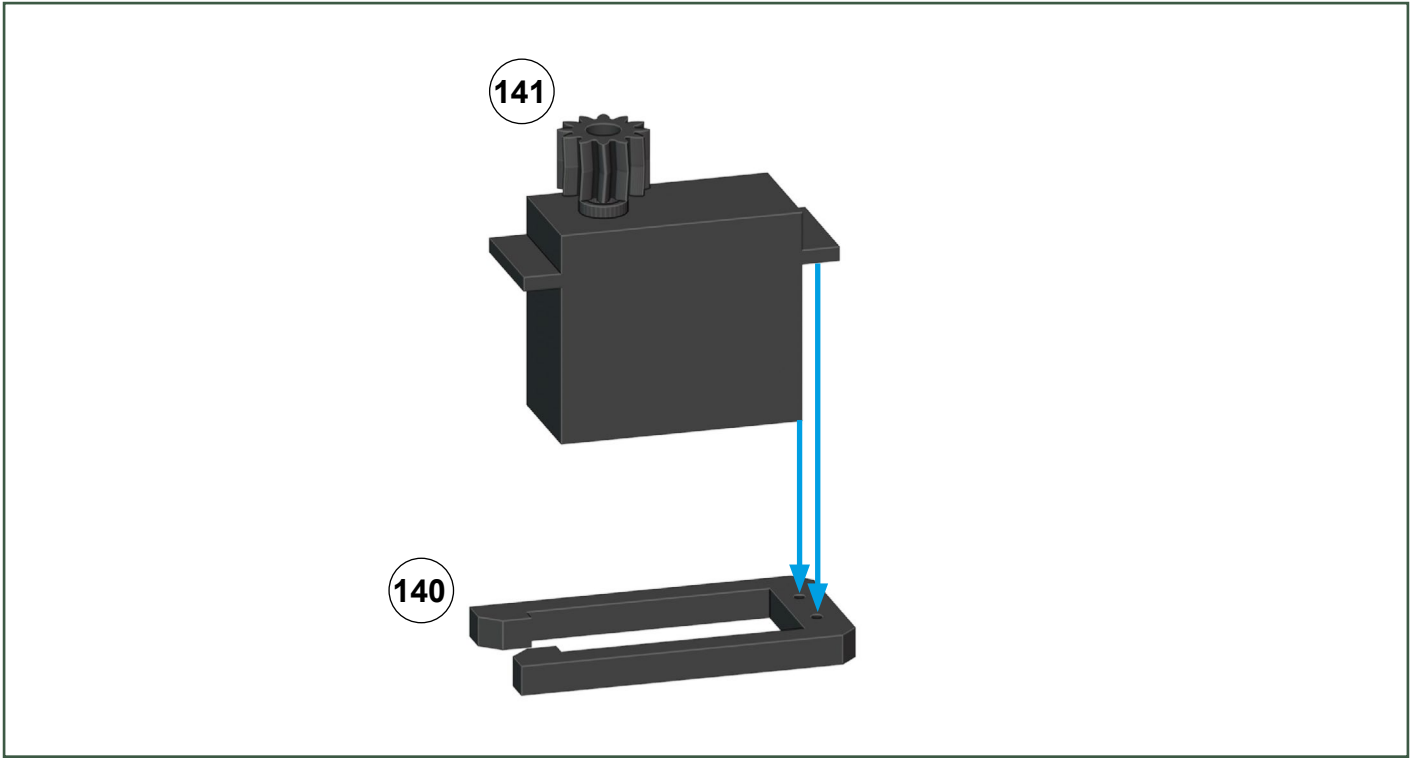

Upper hull:

rubber from bicycle air chamber

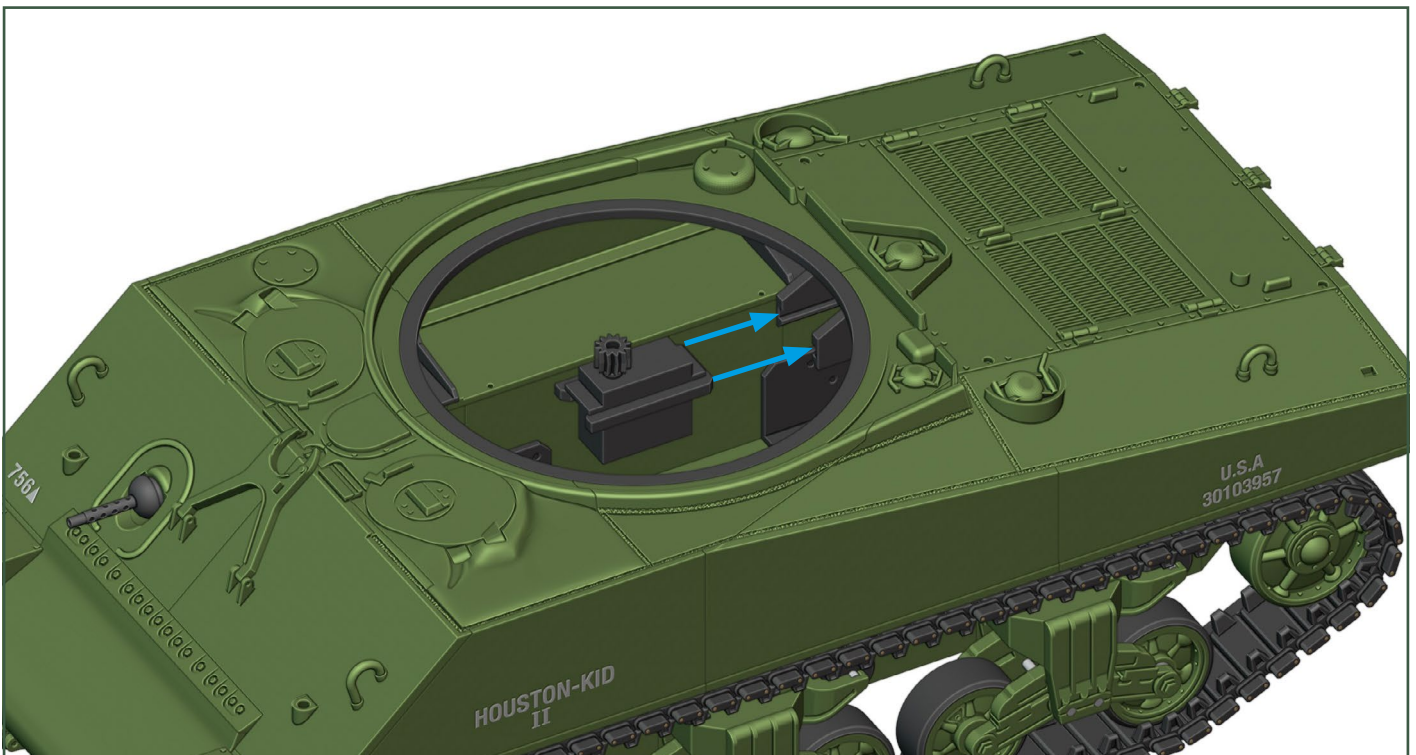

M4A3 Sherman - Build Guide

Upper hull:

rubber position - low tension

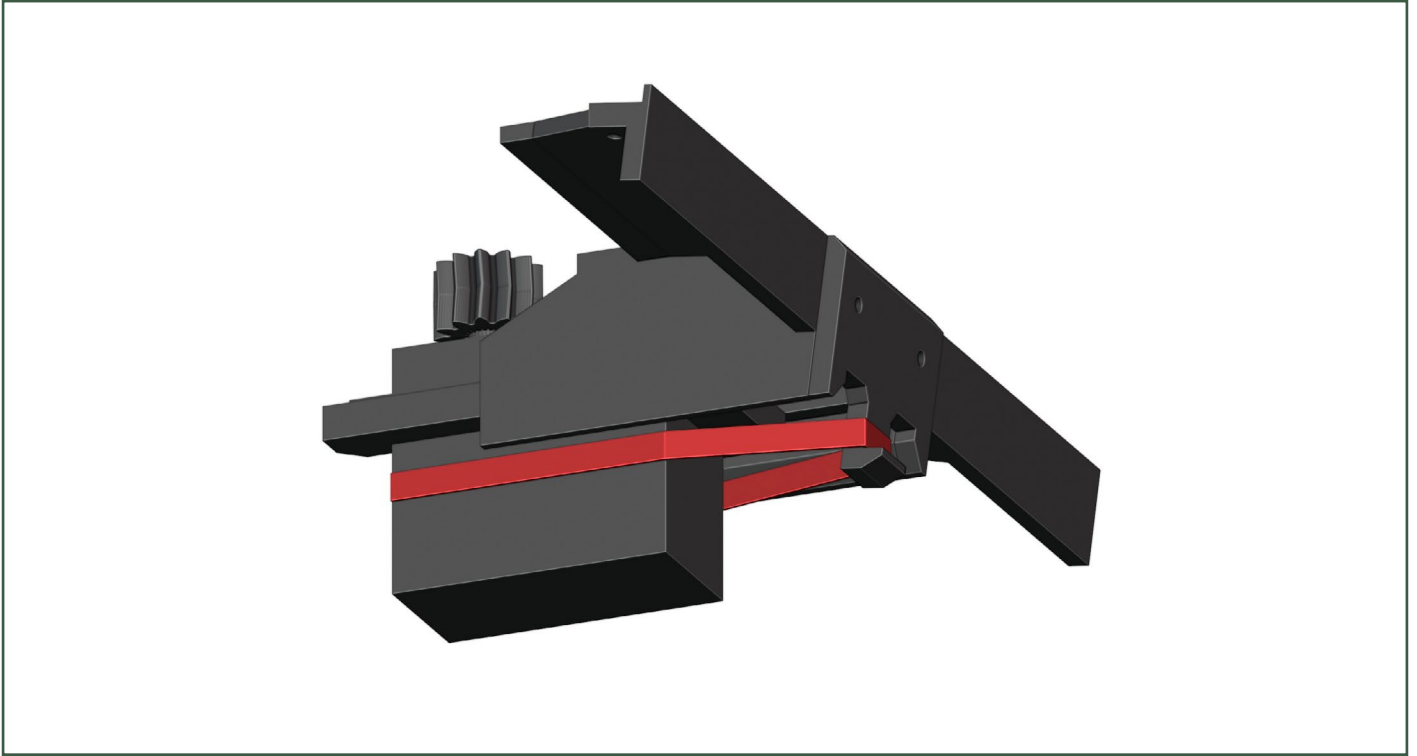

Accessories:

If LEDs are used, shorten them and then polish the surface.

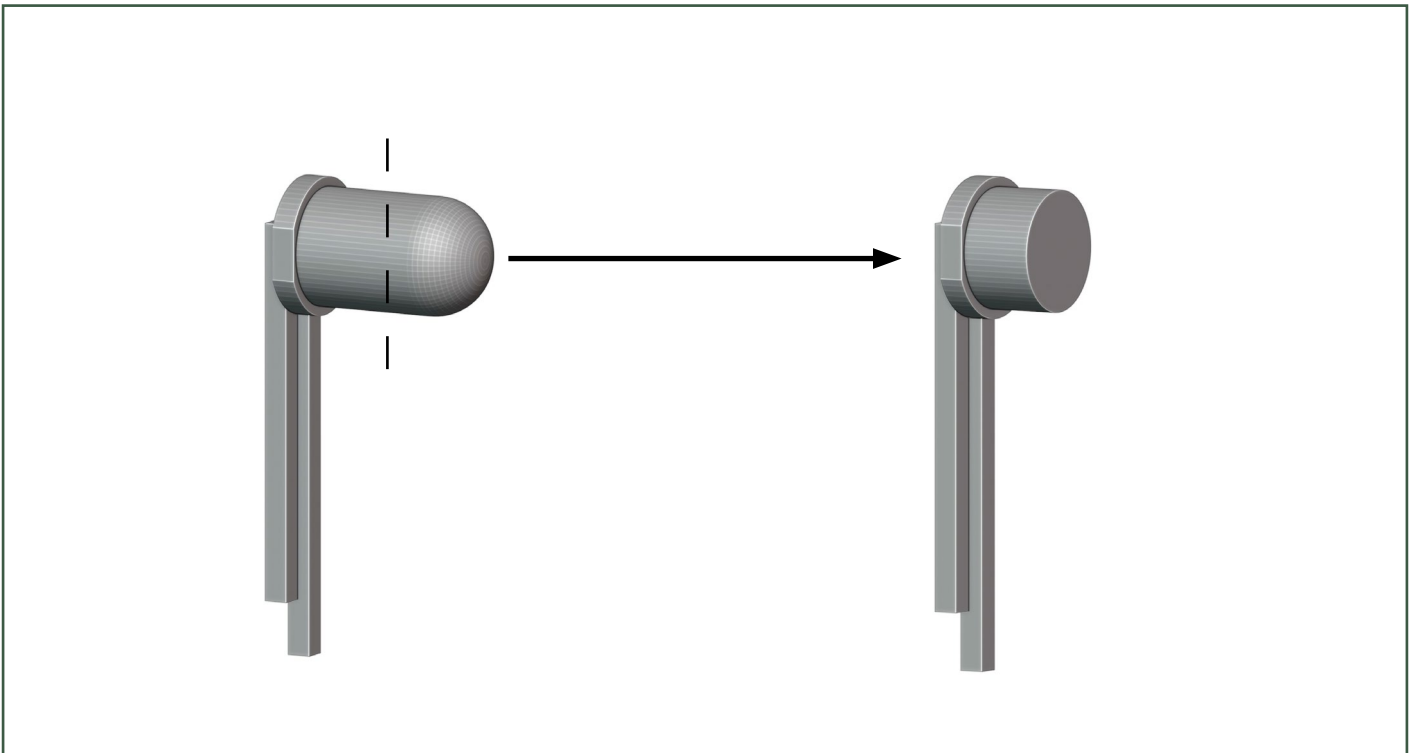

M4A3 Sherman - Build Guide

Accessories:

2x LED 5 mm (warm white)

← use glue

← do not glue

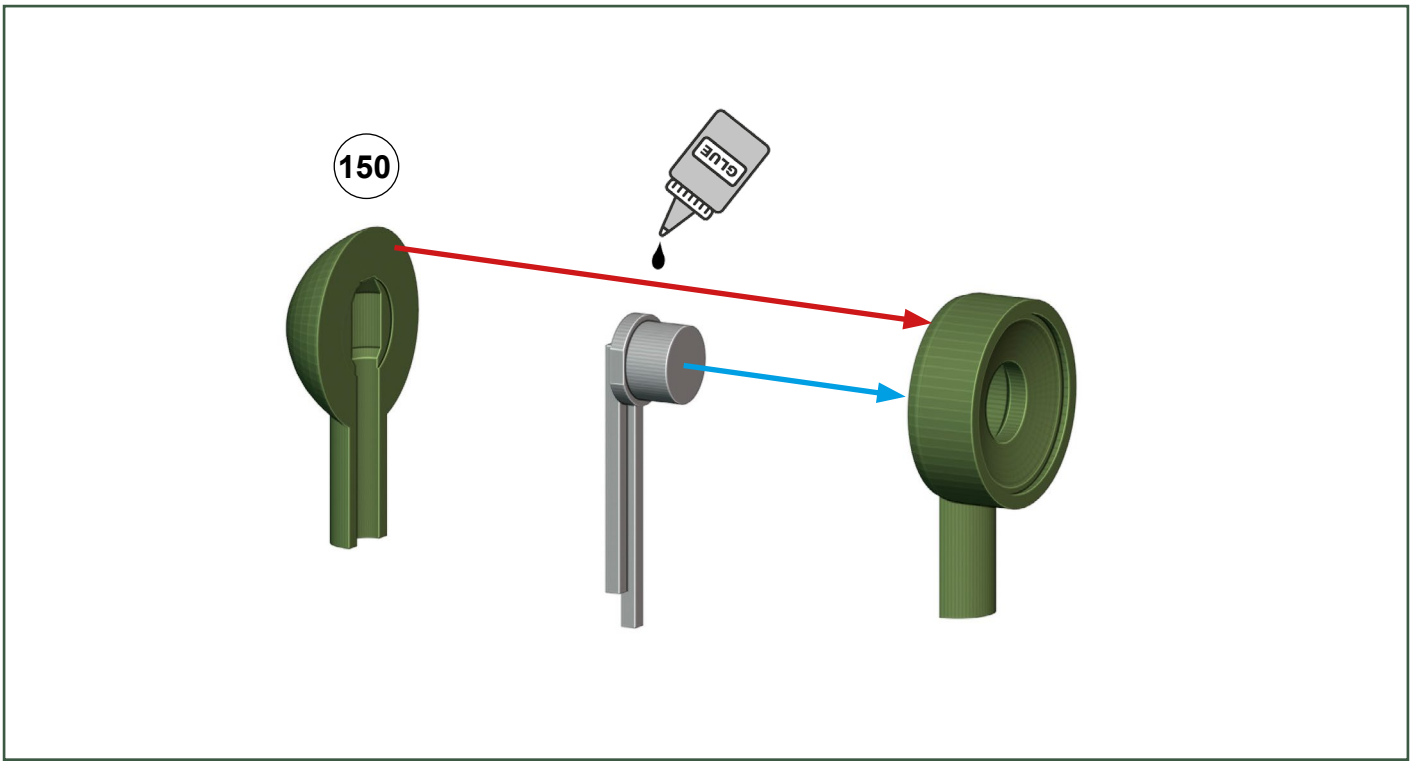

Accessories:

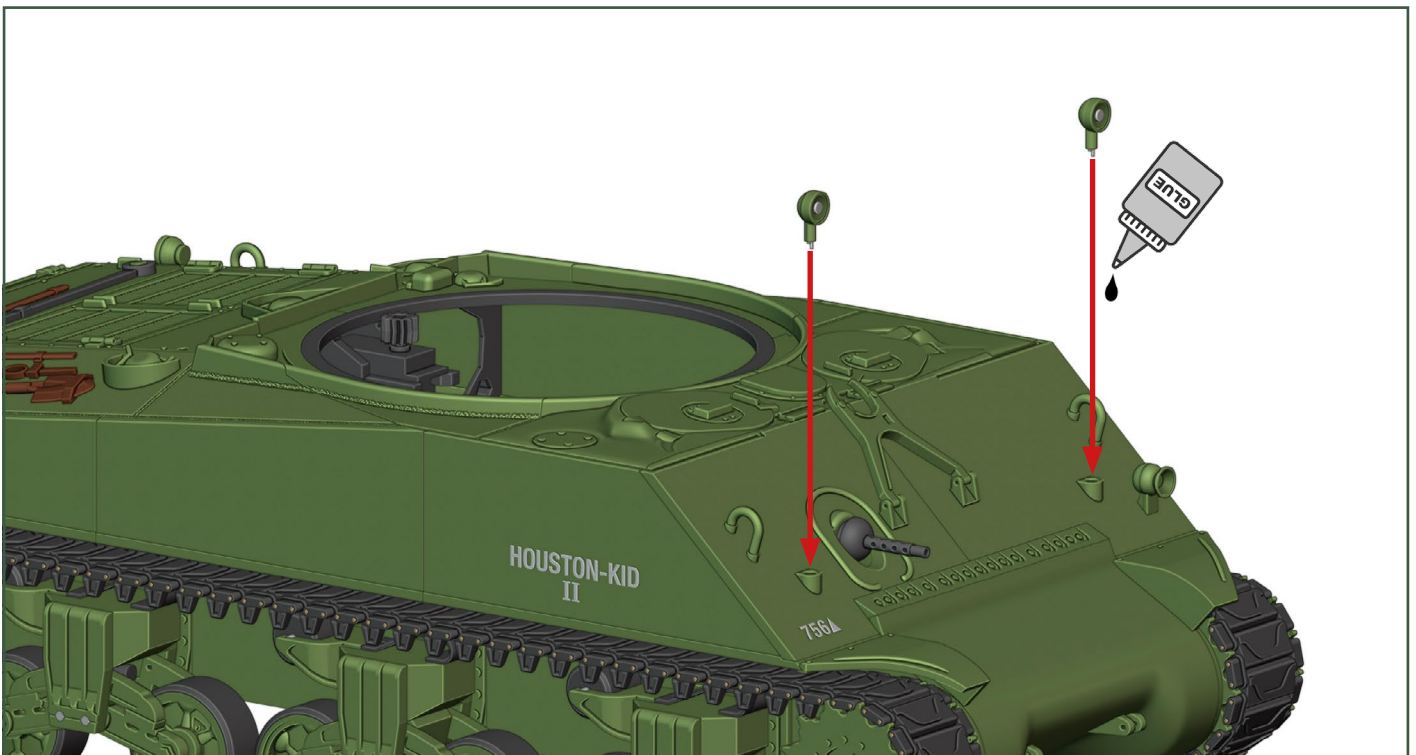

M4A3 Sherman - Build Guide

Accessories:

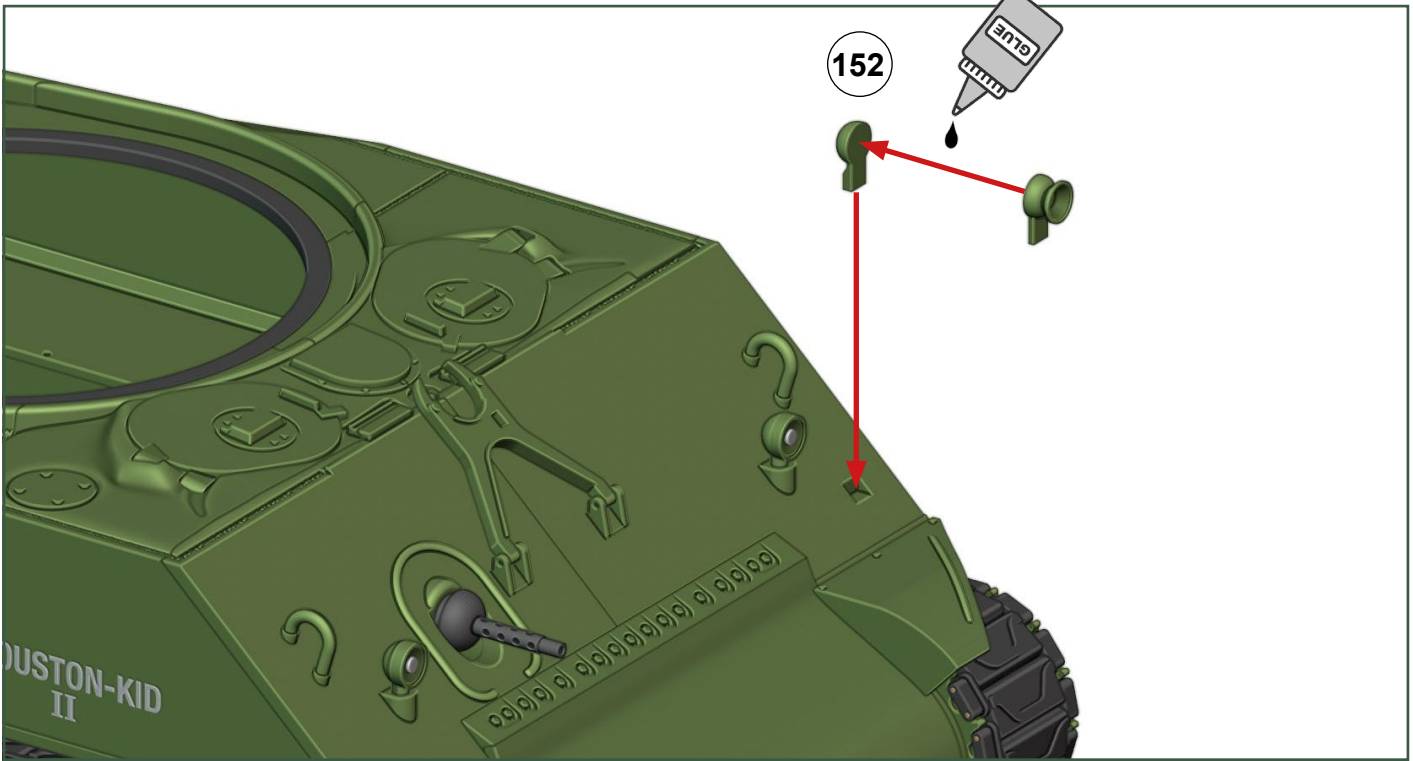

Accessories:

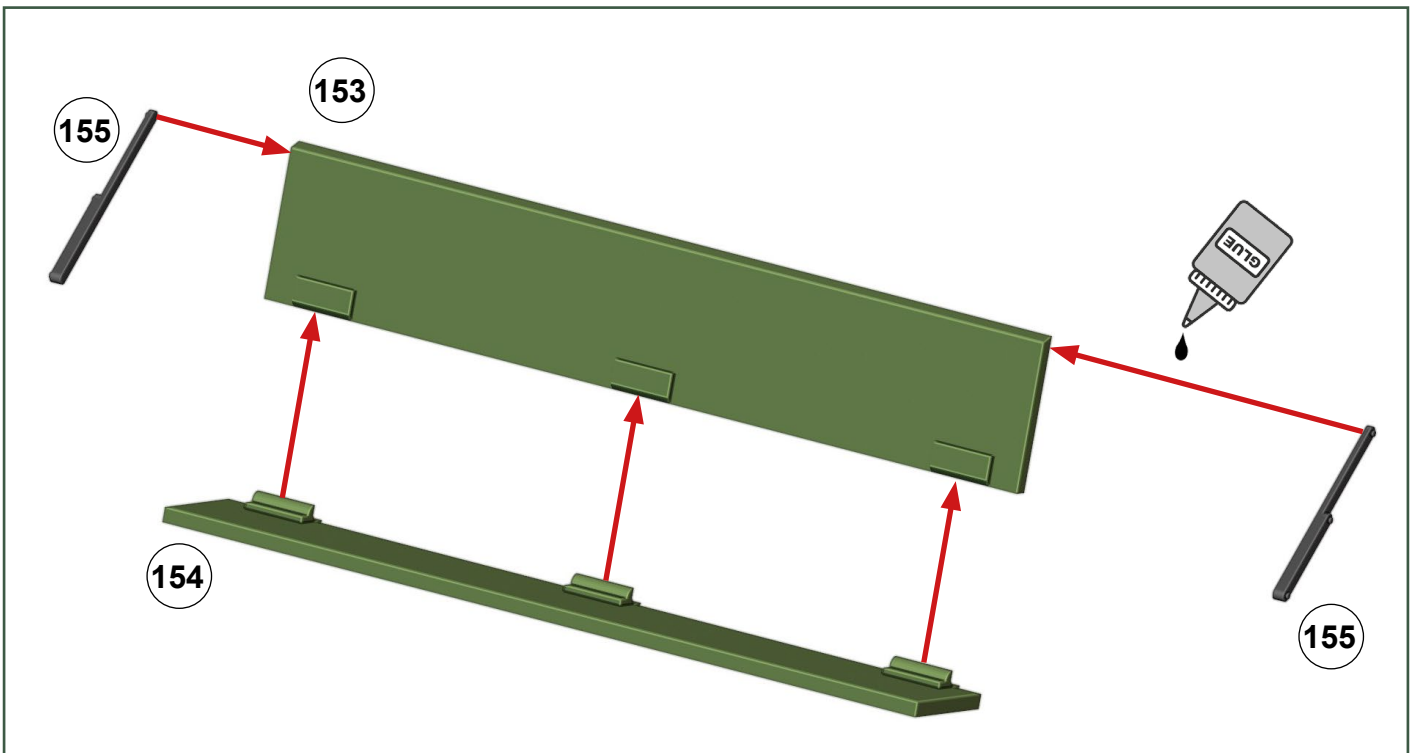

M4A3 Sherman – Build Guide

Accessories:

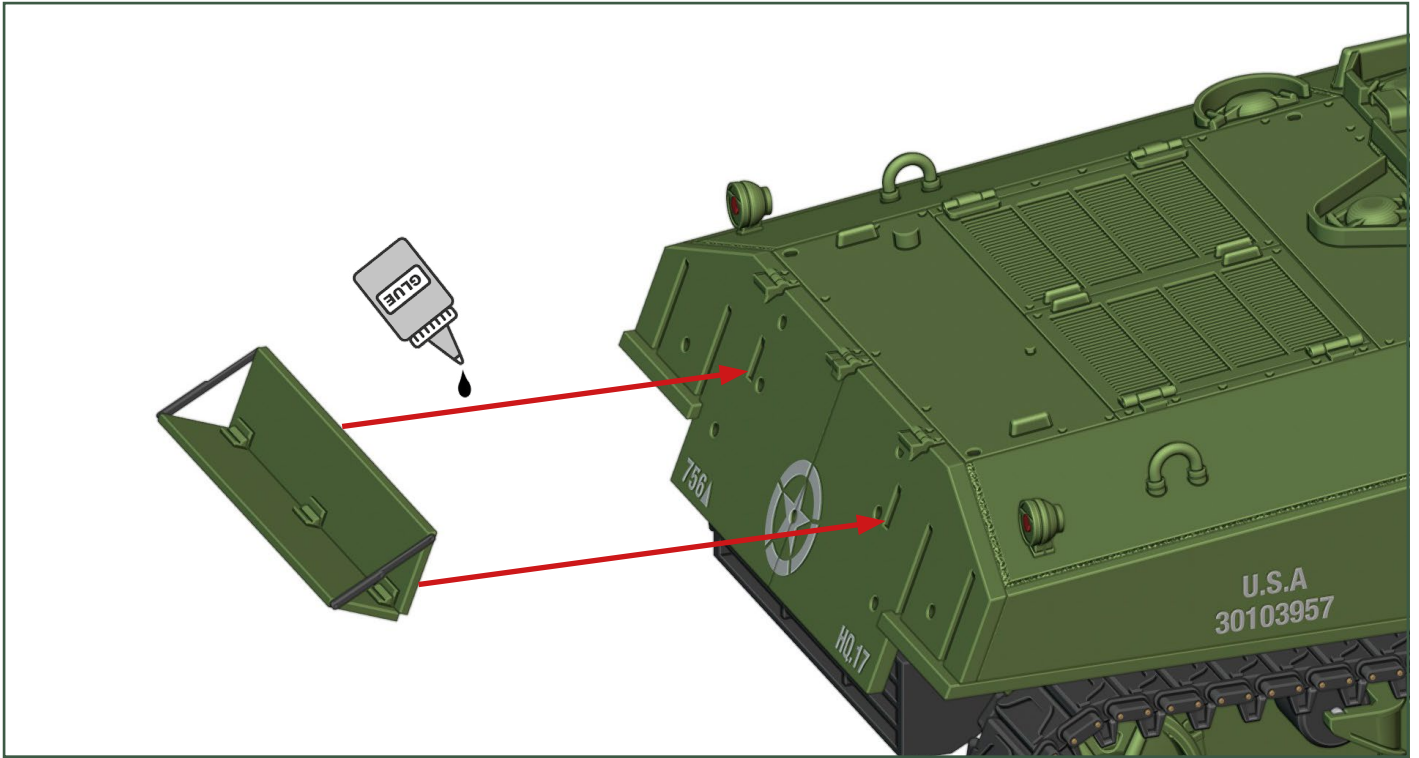

Accessories:

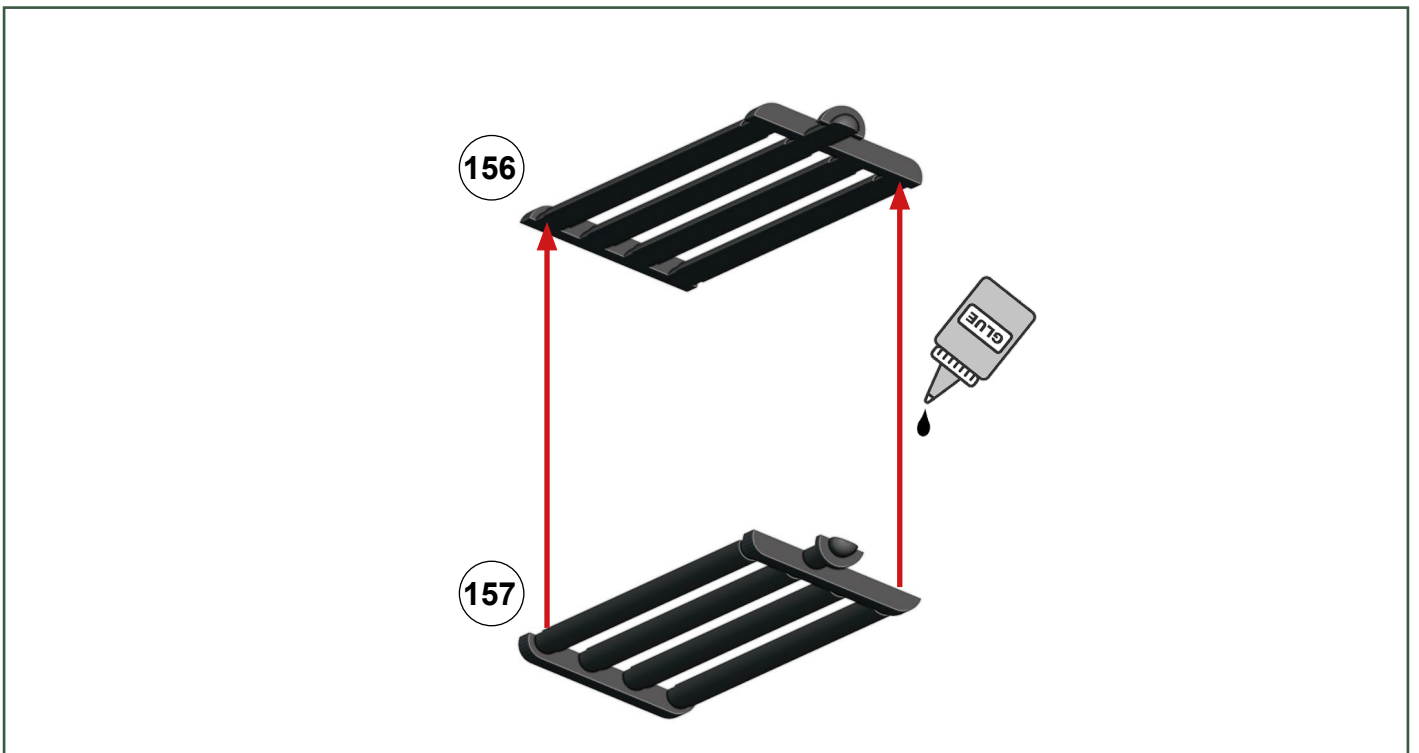

M4A3 Sherman – Build Guide

Accessories:

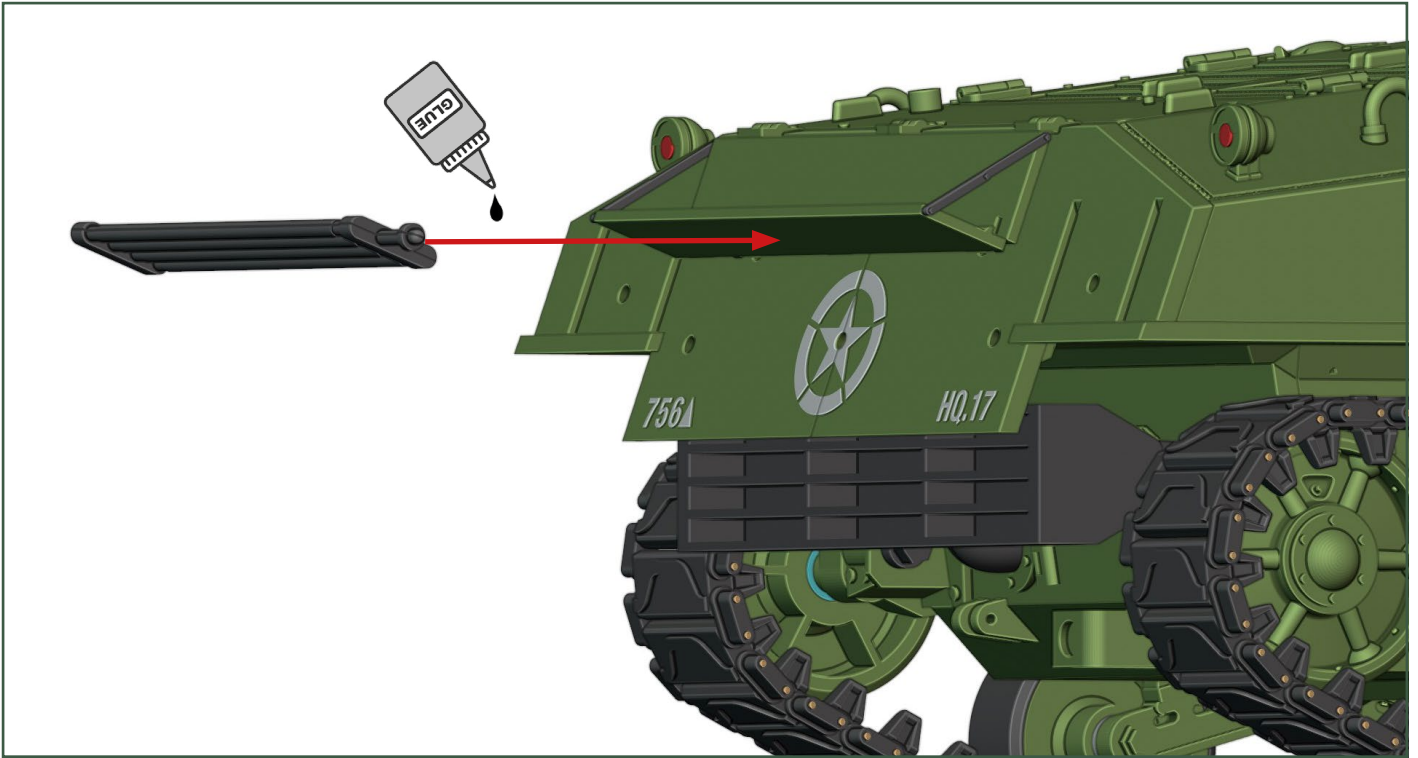

Accessories:

2x

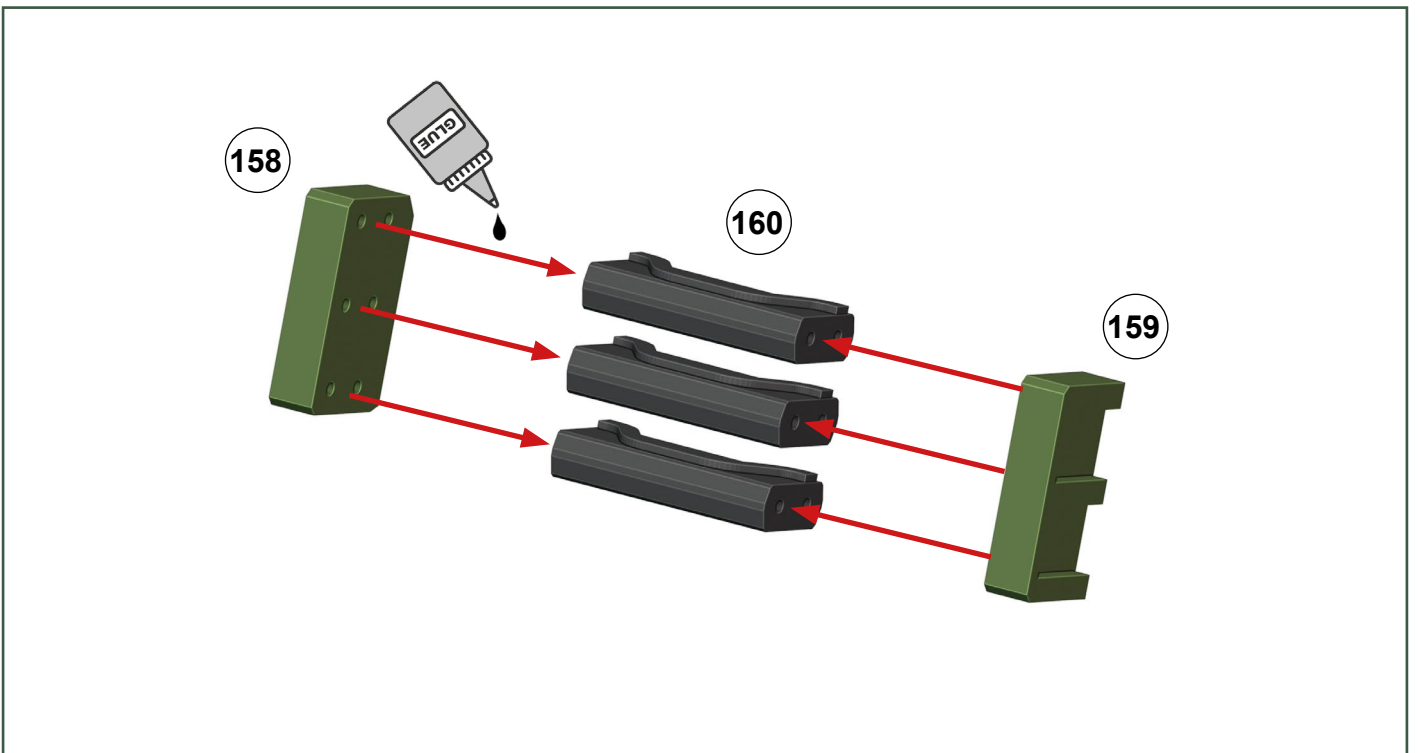

M4A3 Sherman – Build Guide

Accessories:

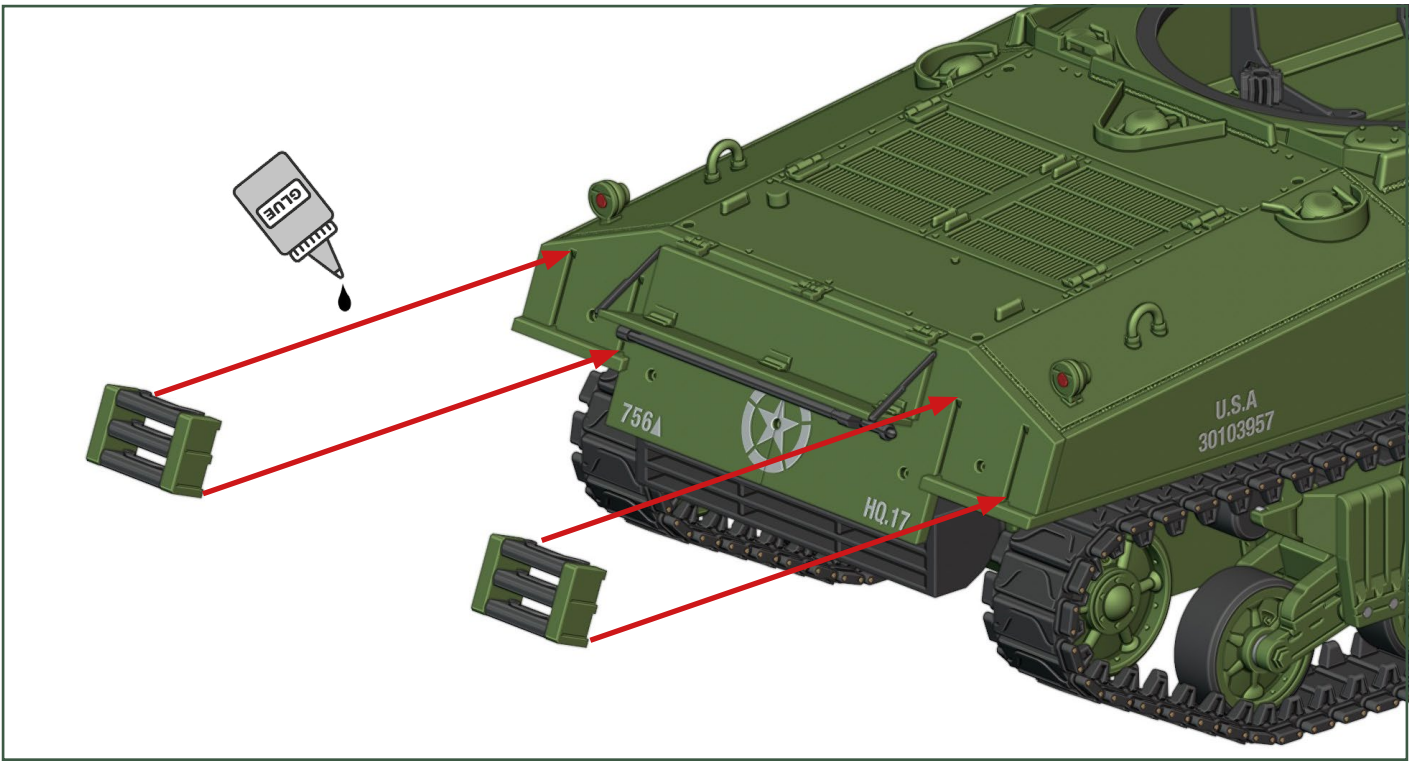

Accessories:

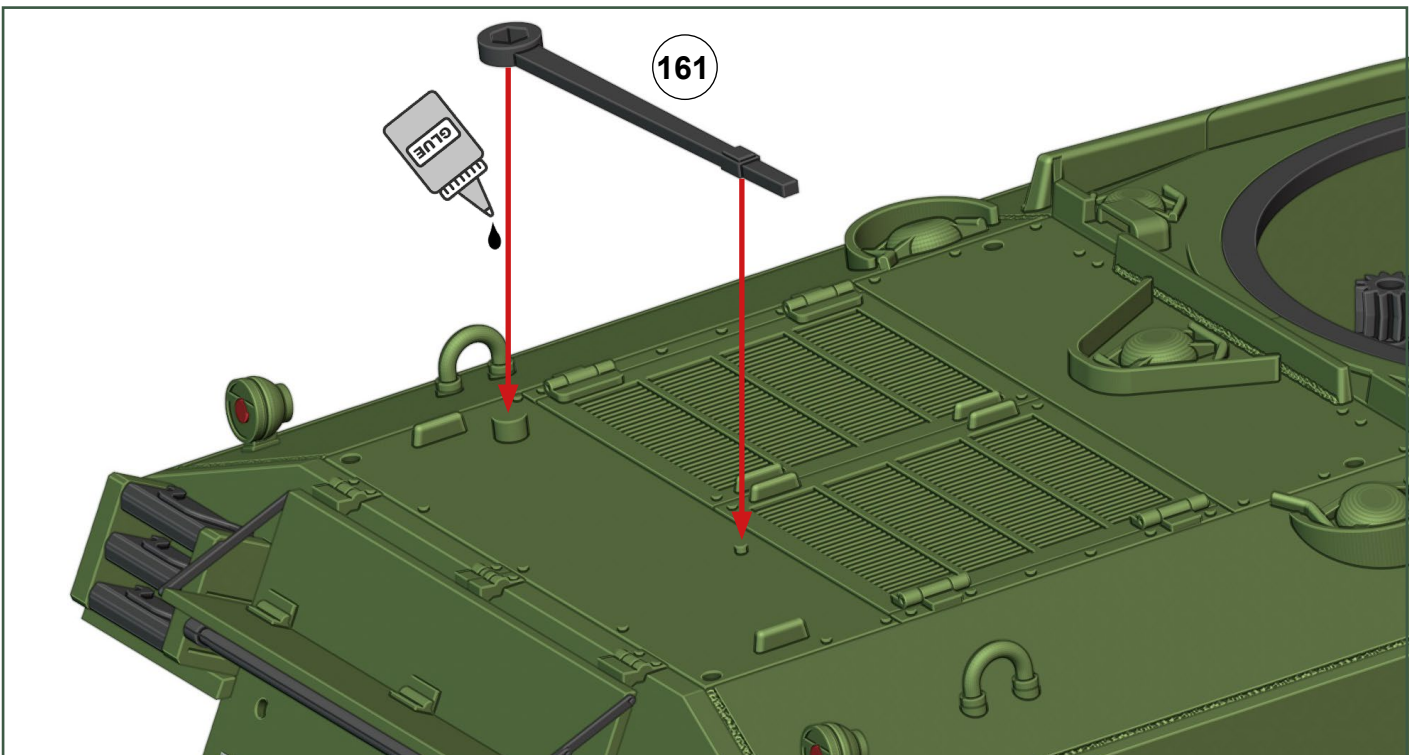

M4A3 Sherman – Build Guide

Accessories:

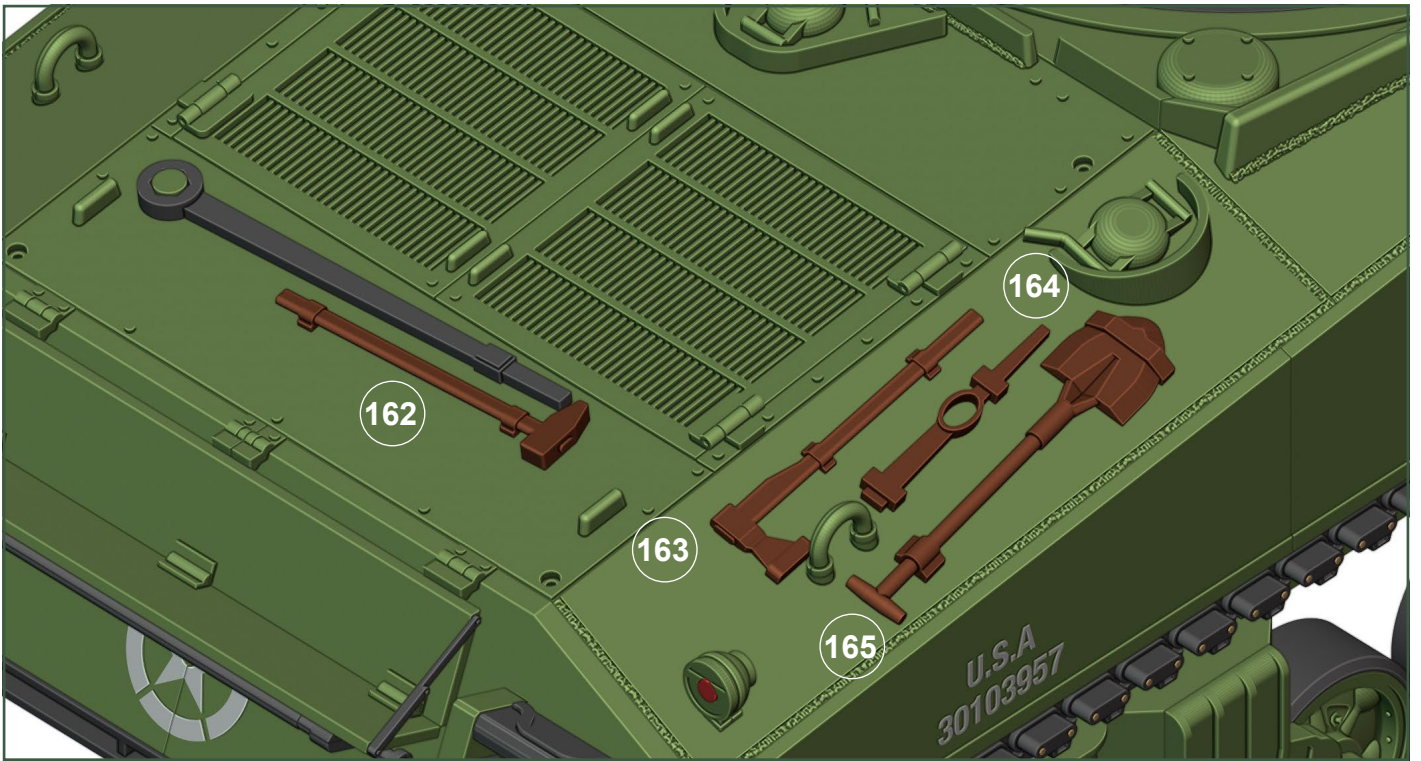

M4A3 Sherman - Build Guide

Turret:

6x M3 screw 8 mm, 6x M3 nut

← use glue

← do not glue

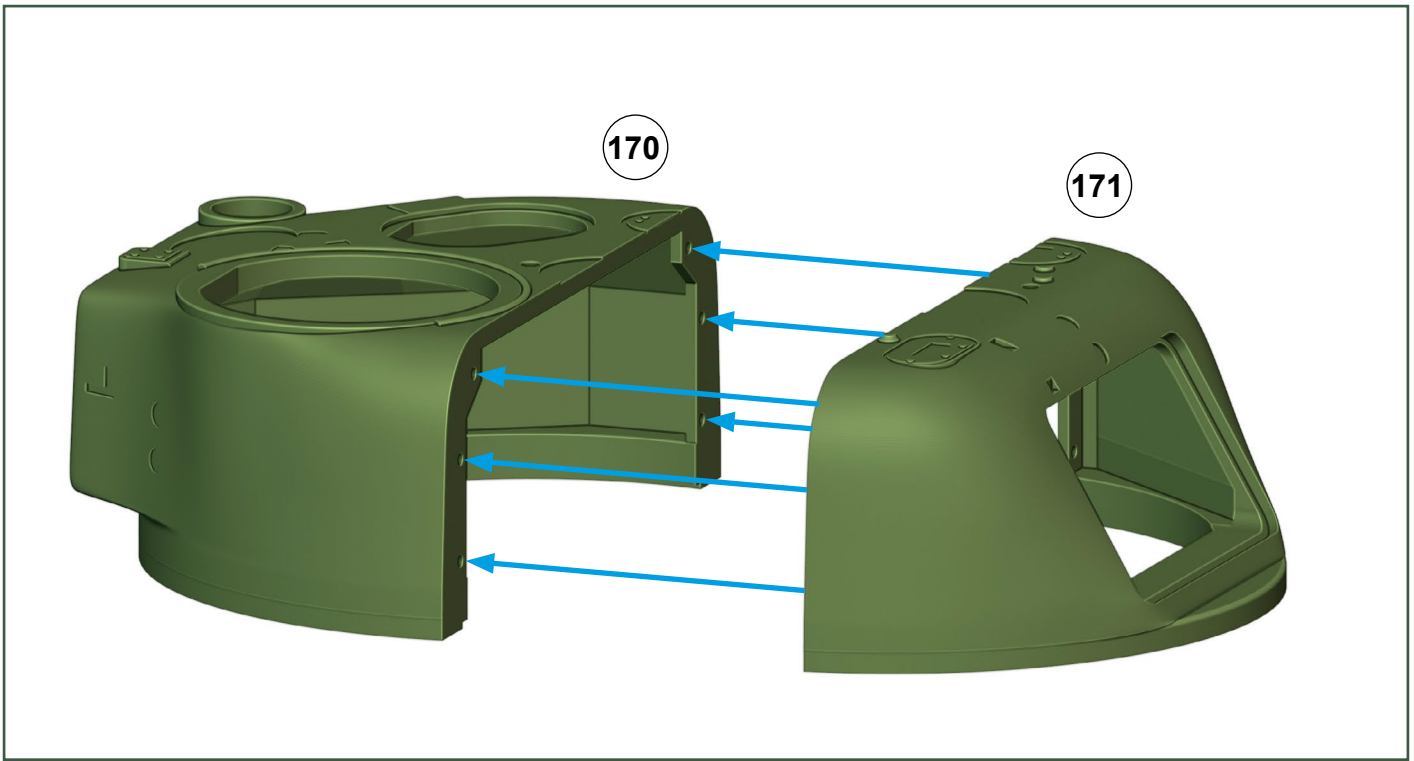

Turret:

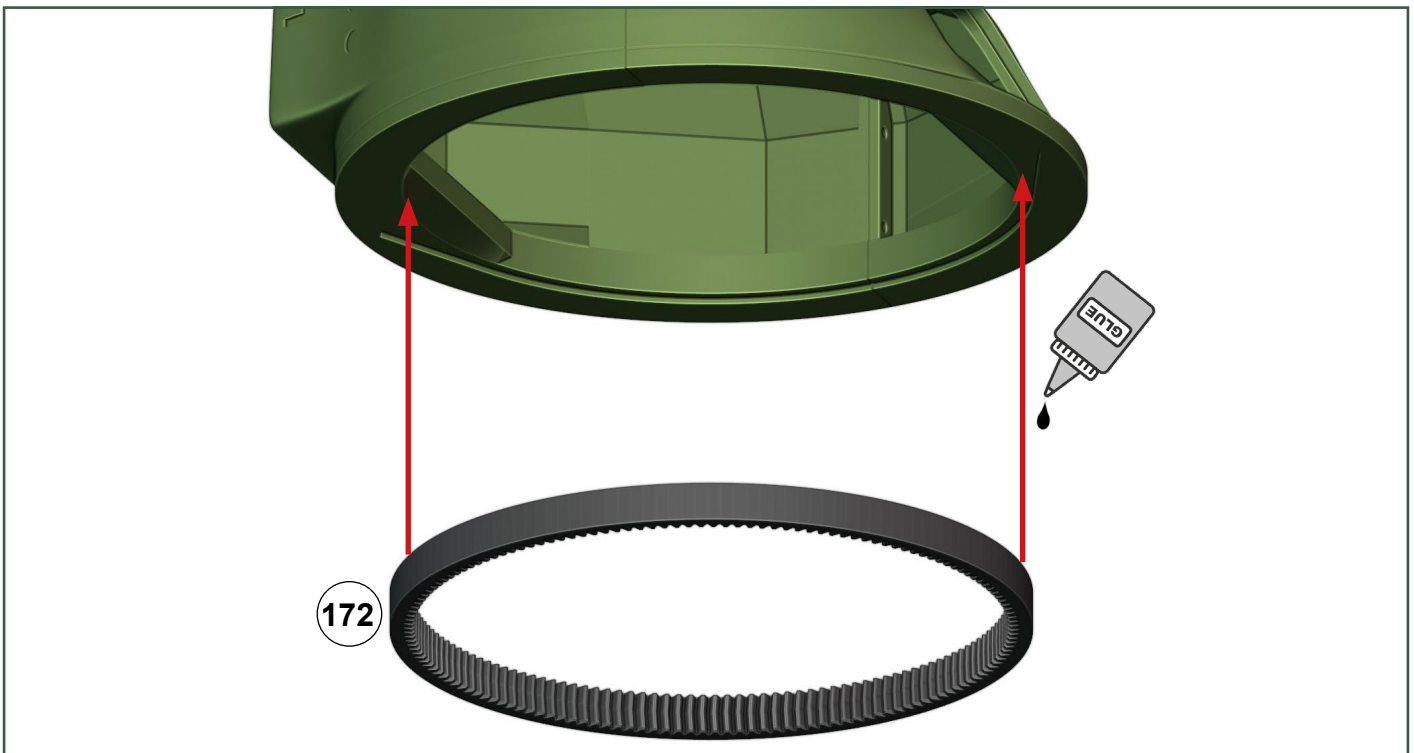

M4A3 Sherman – Build Guide

Turret:

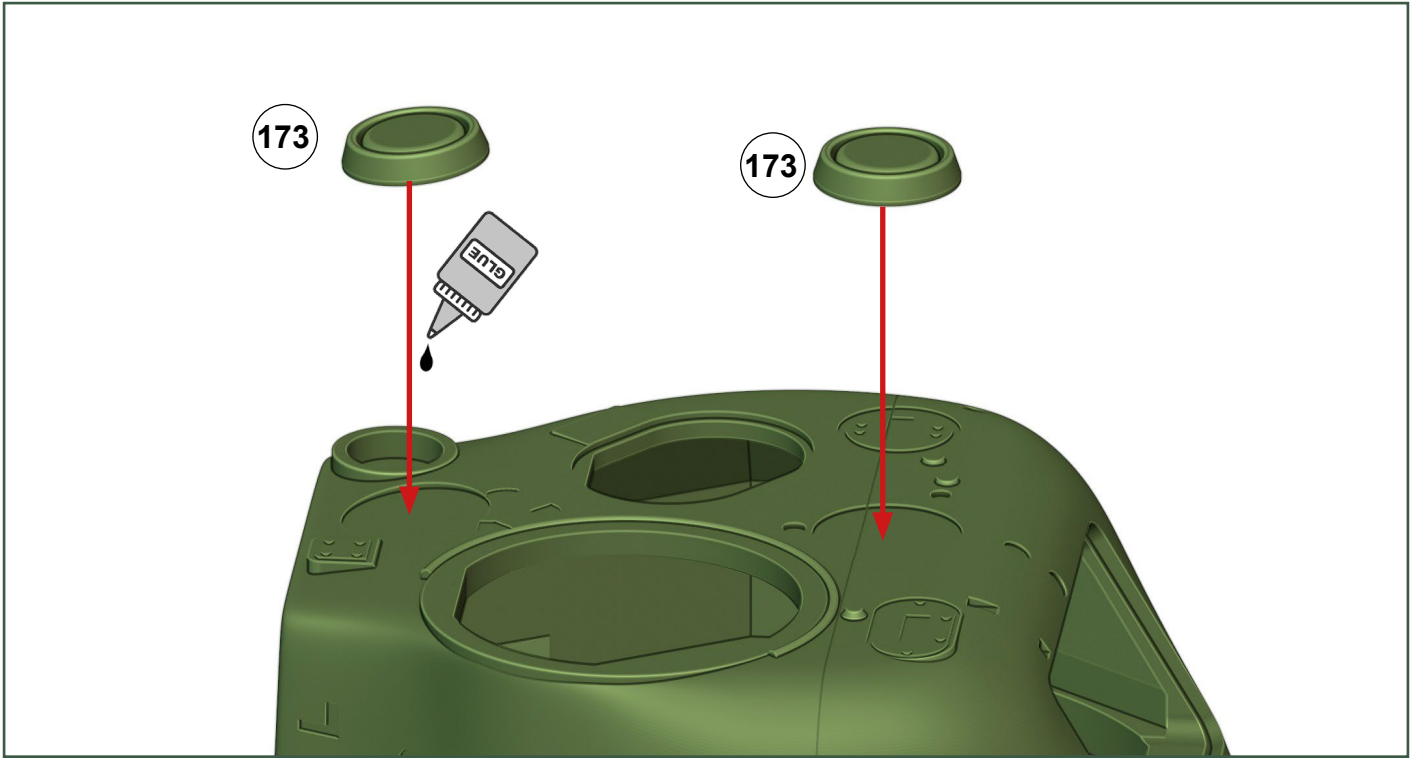

Turret:

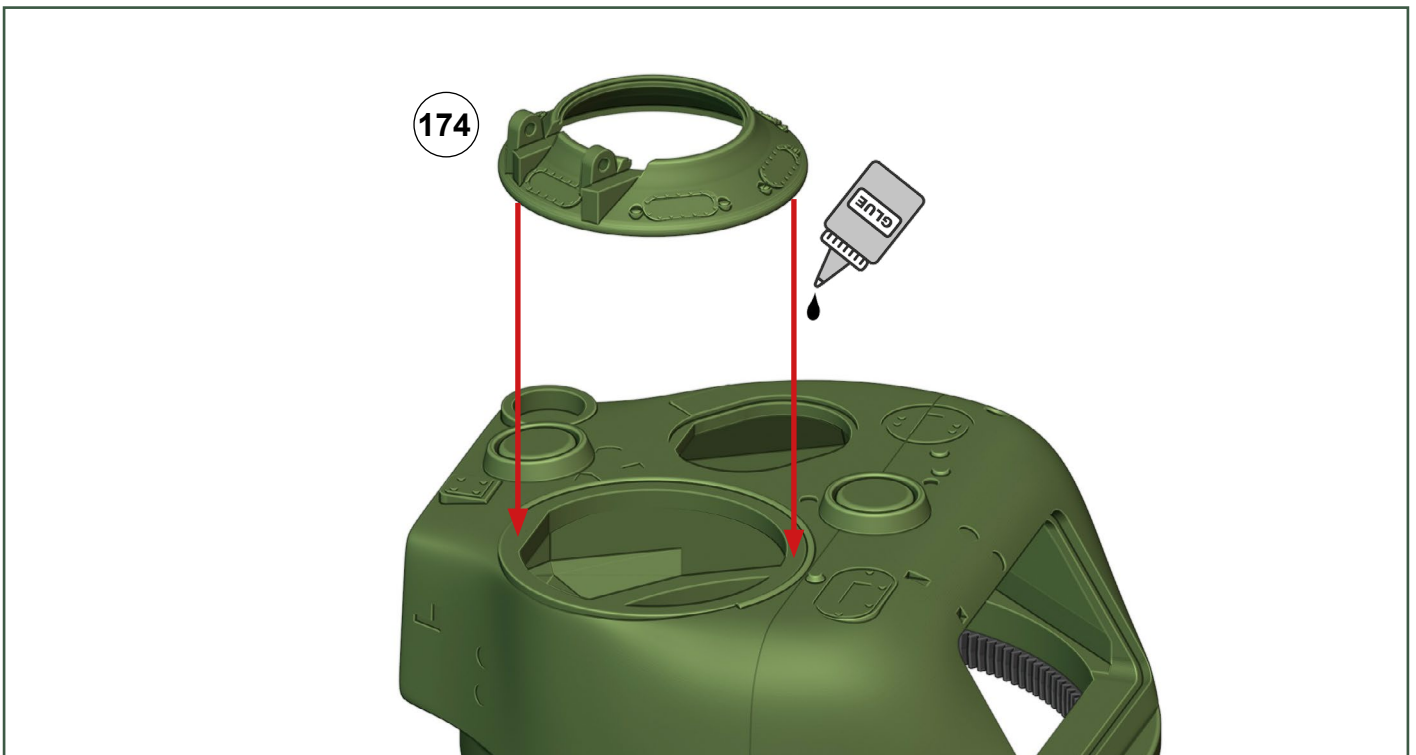

M4A3 Sherman - Build Guide

Turret:

part 174 position



Turret:

glue the rod 175 to the cover 176, keep it hinged

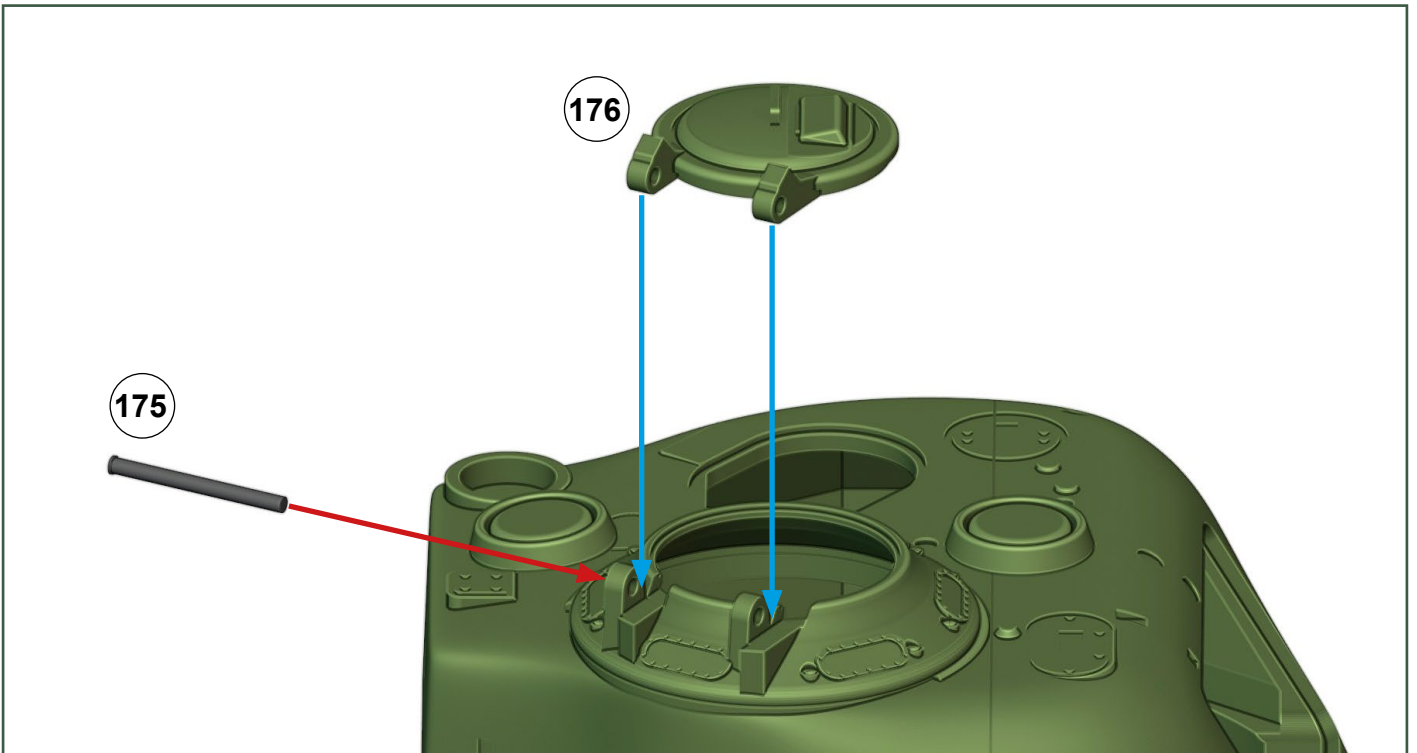

M4A3 Sherman – Build Guide

Turret:

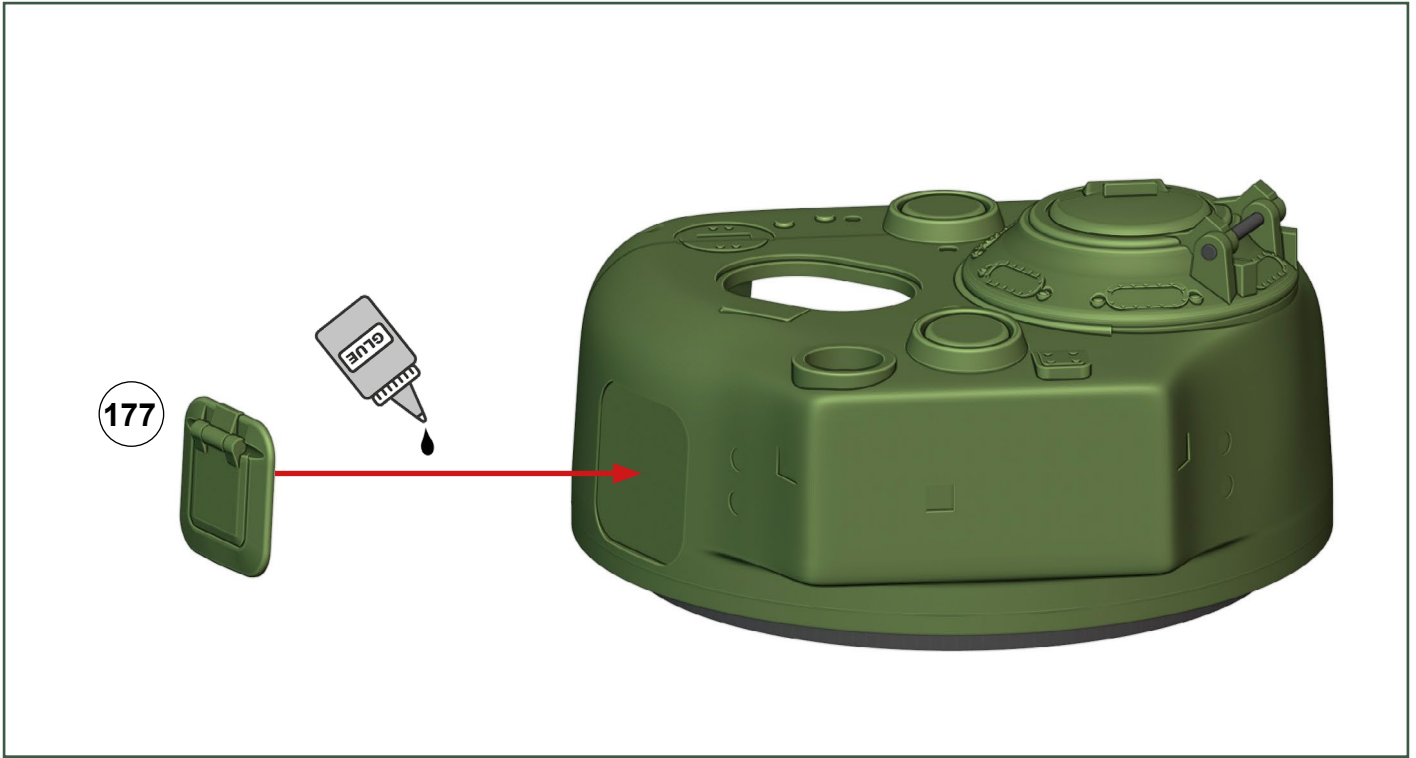

Turret:

wire 1,2 x 20 mm

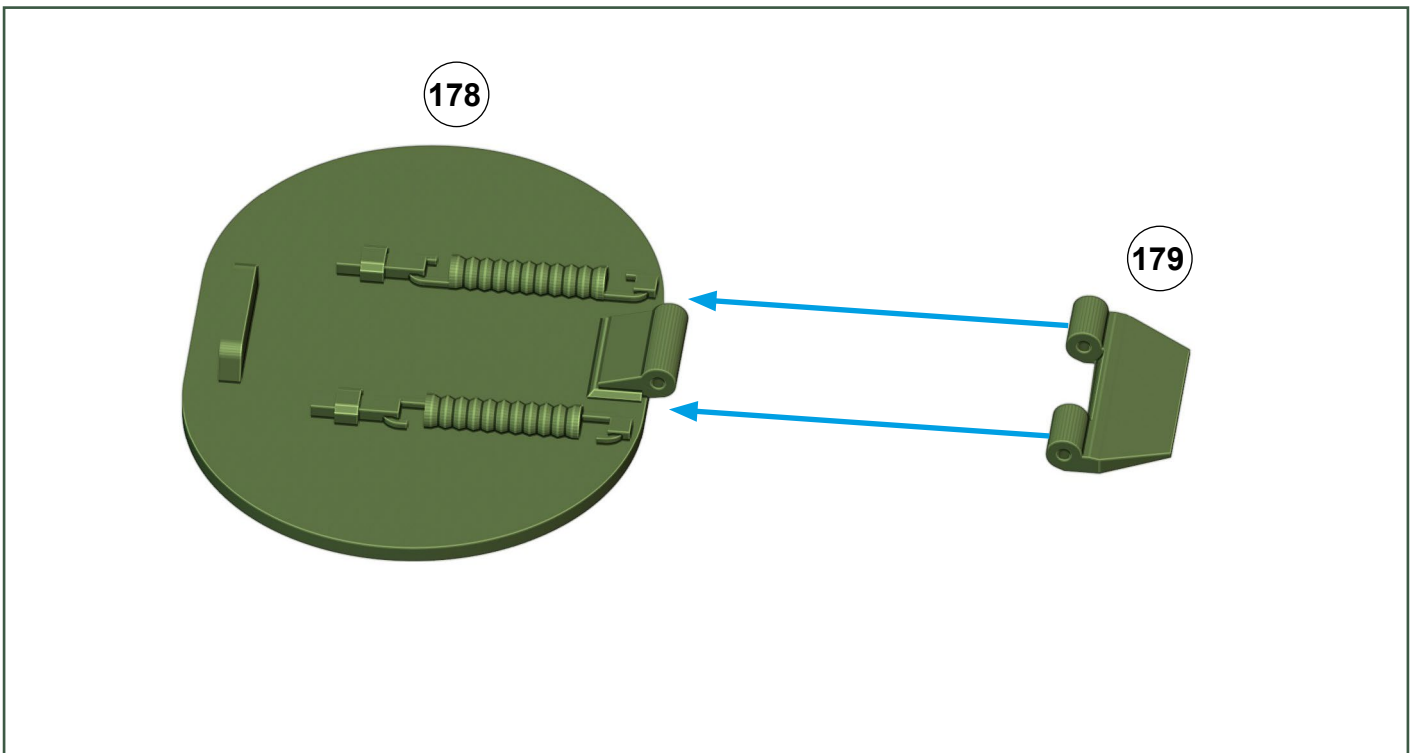

M4A3 Sherman - Build Guide

Turret:

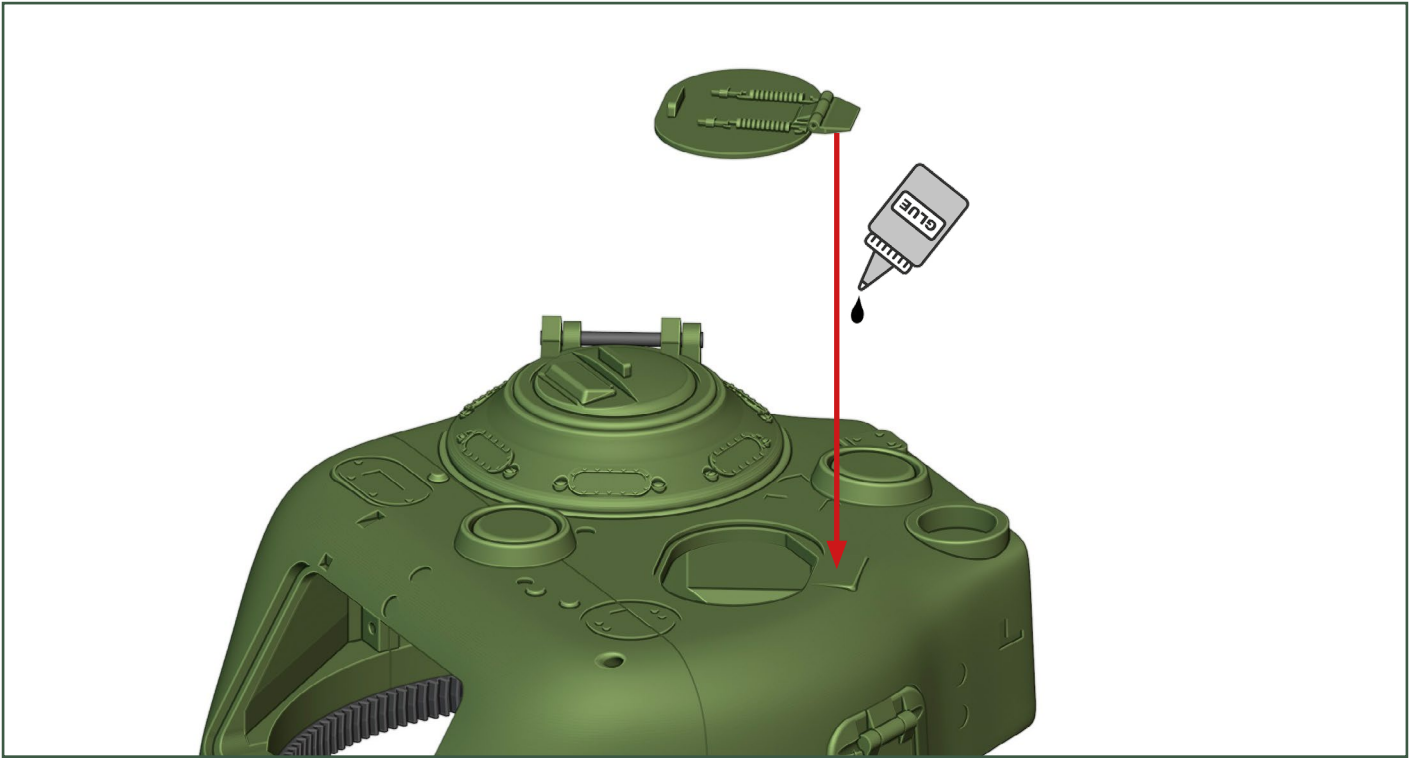

Turret:

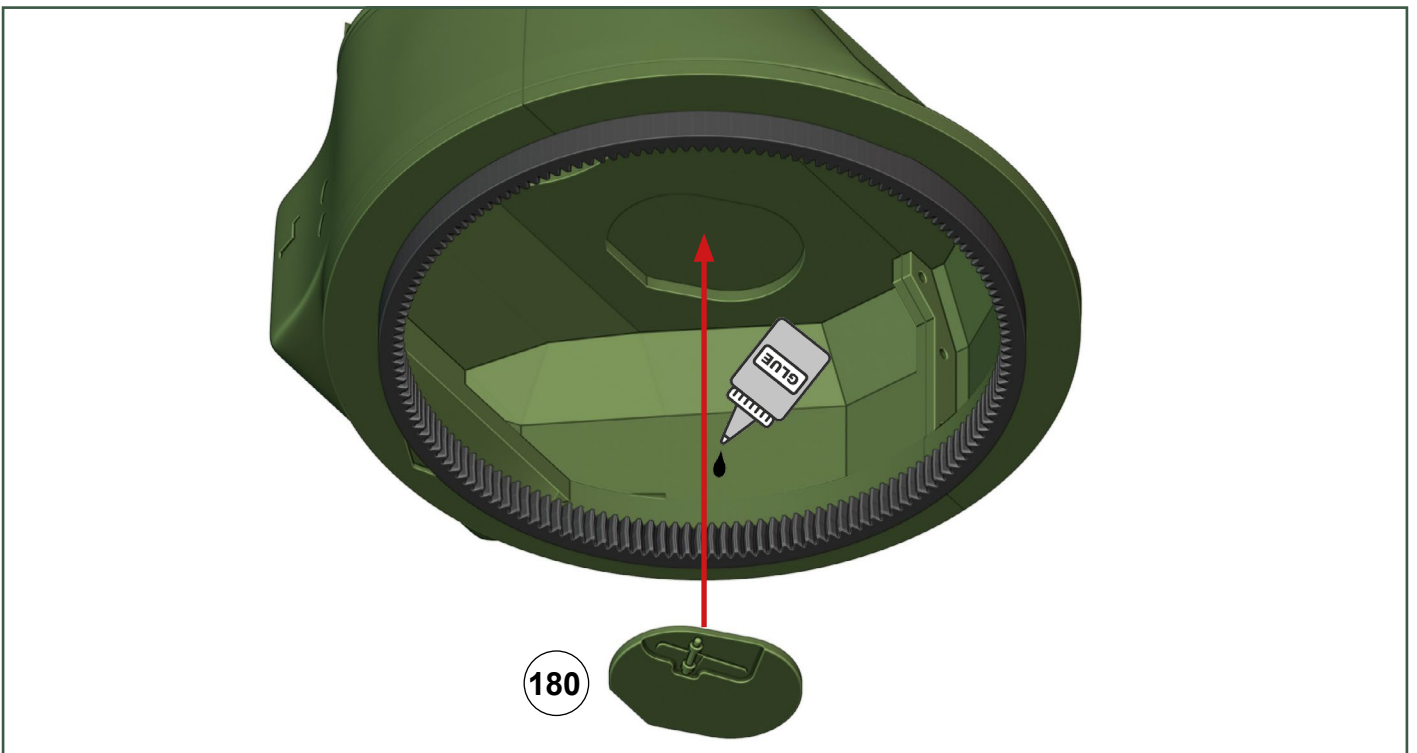

M4A3 Sherman – Build Guide

Turret:

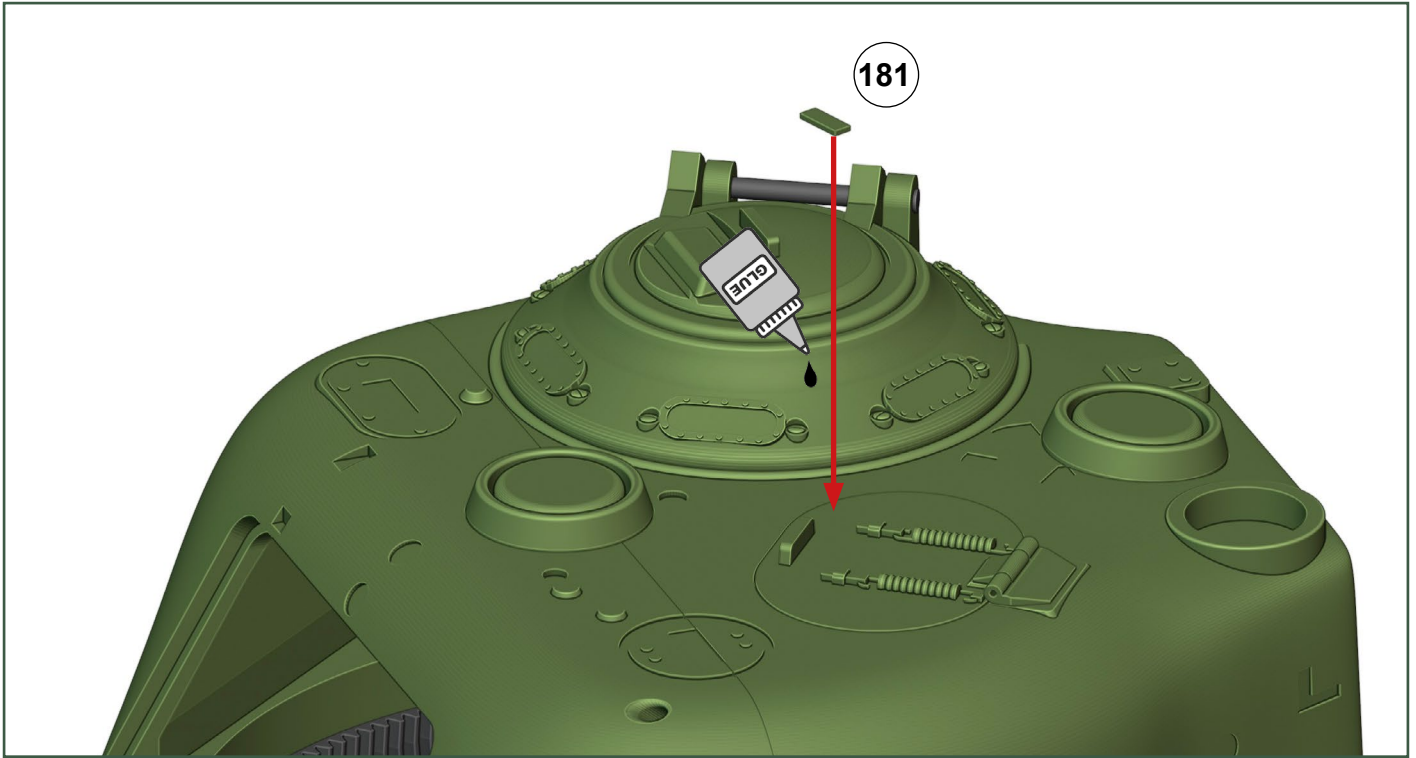

Turret:

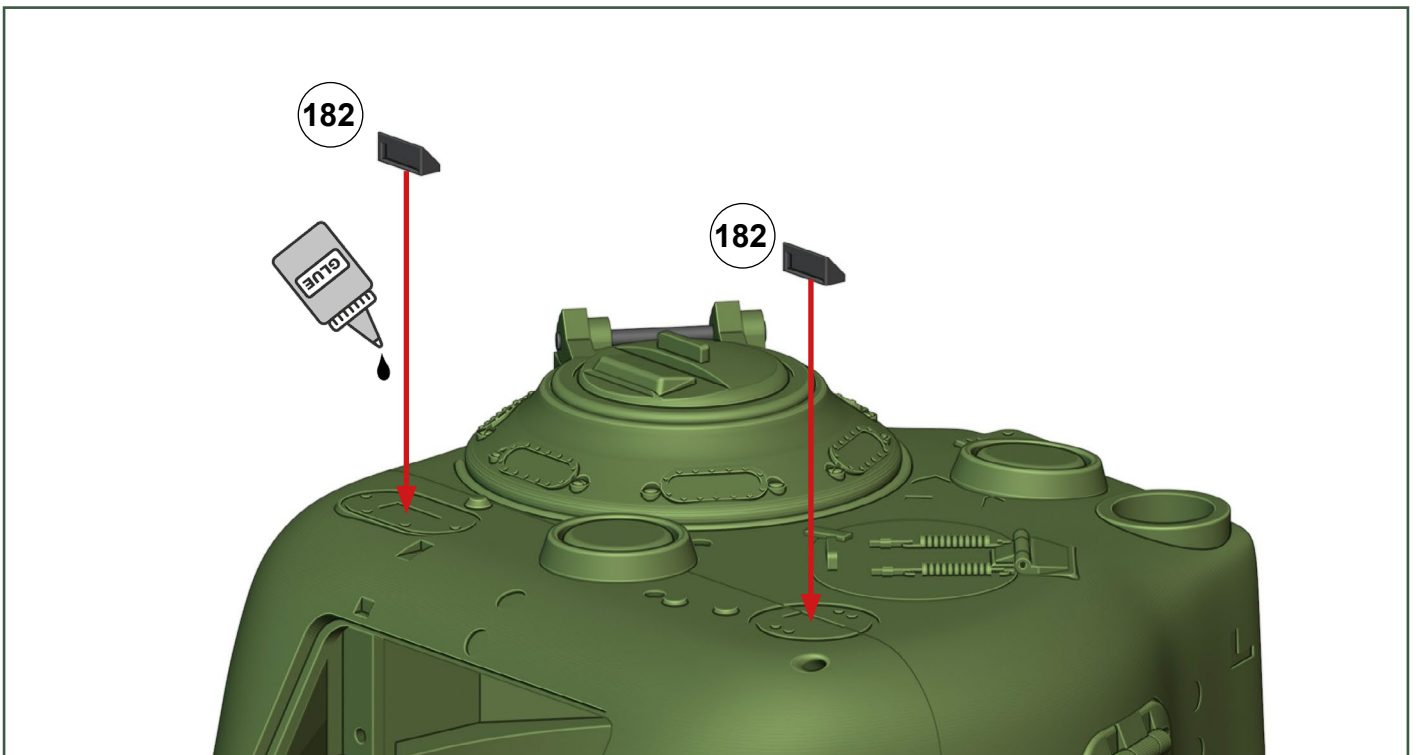

M4A3 Sherman – Build Guide

Turret:

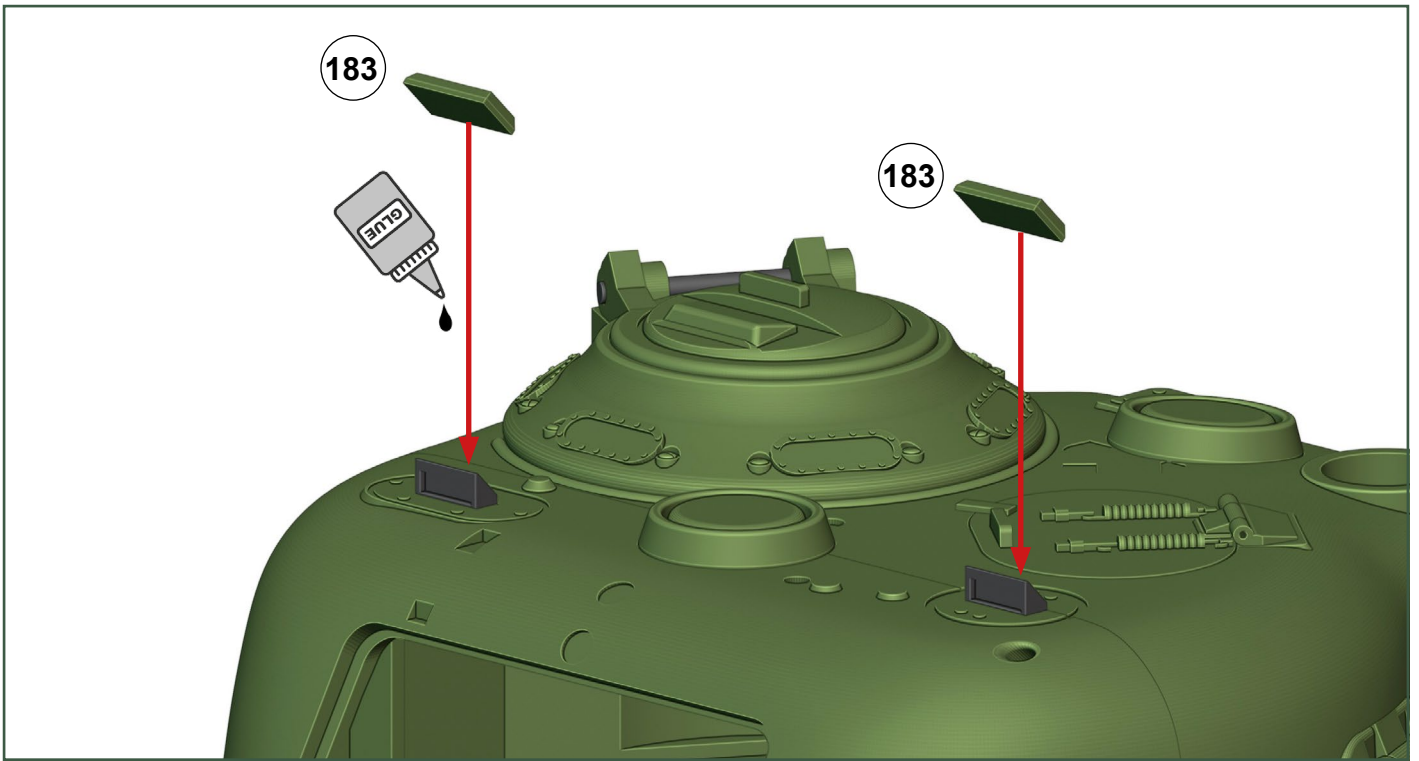

Turret:

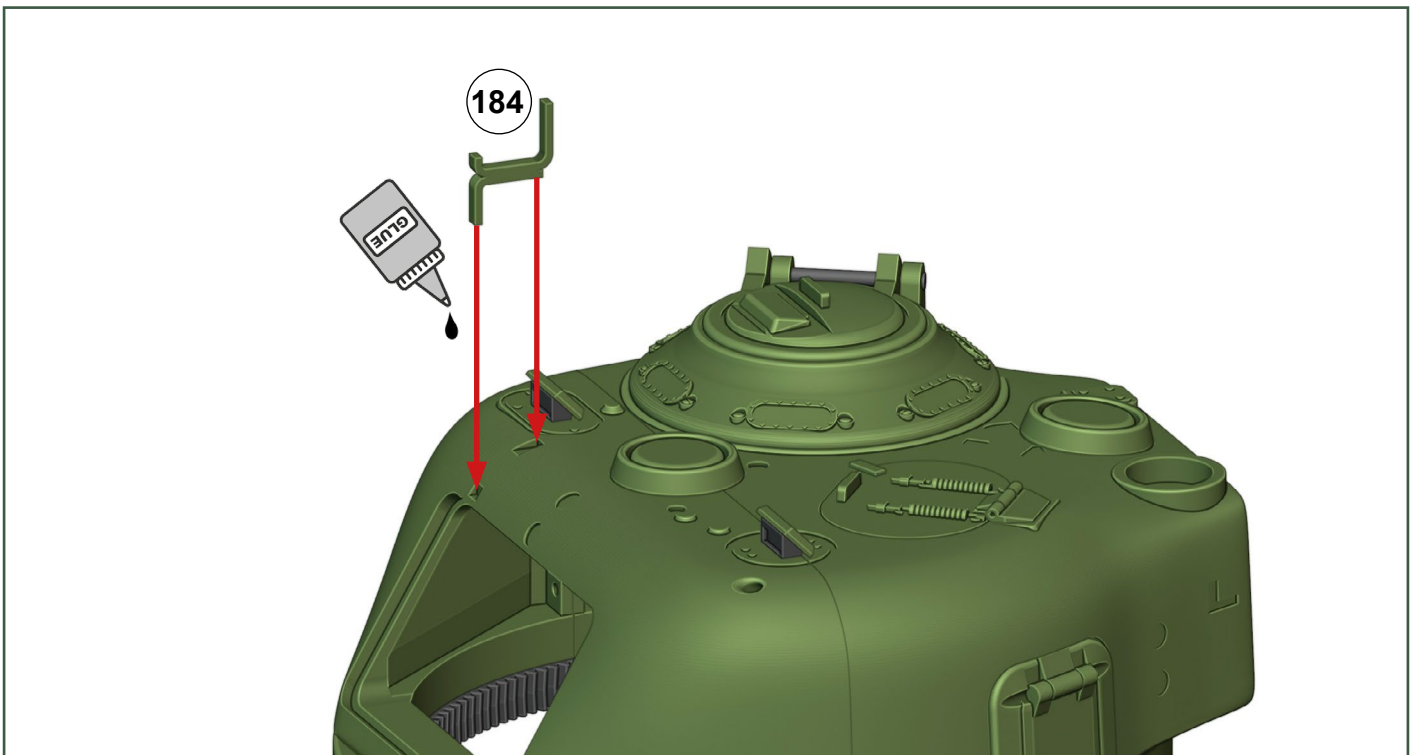

M4A3 Sherman – Build Guide

Turret:

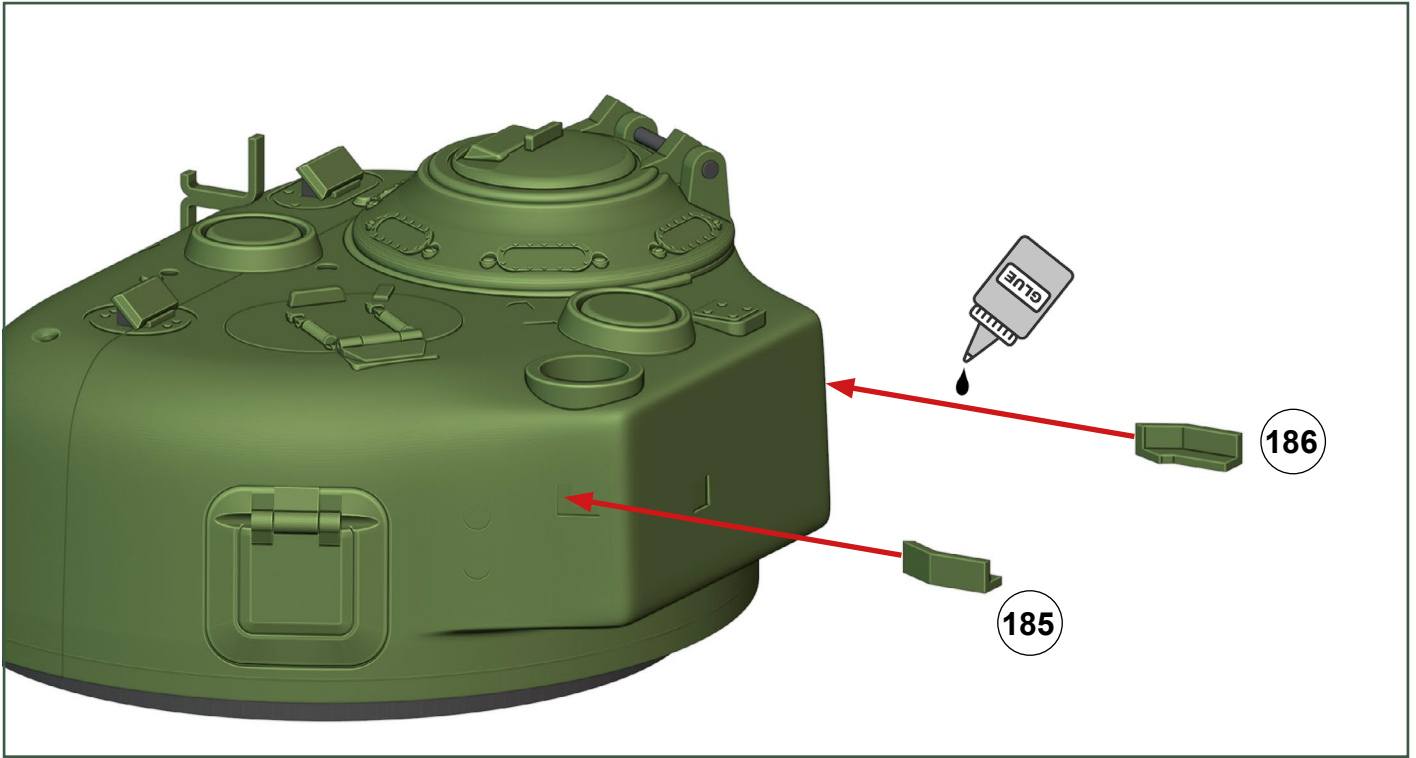

Turret:

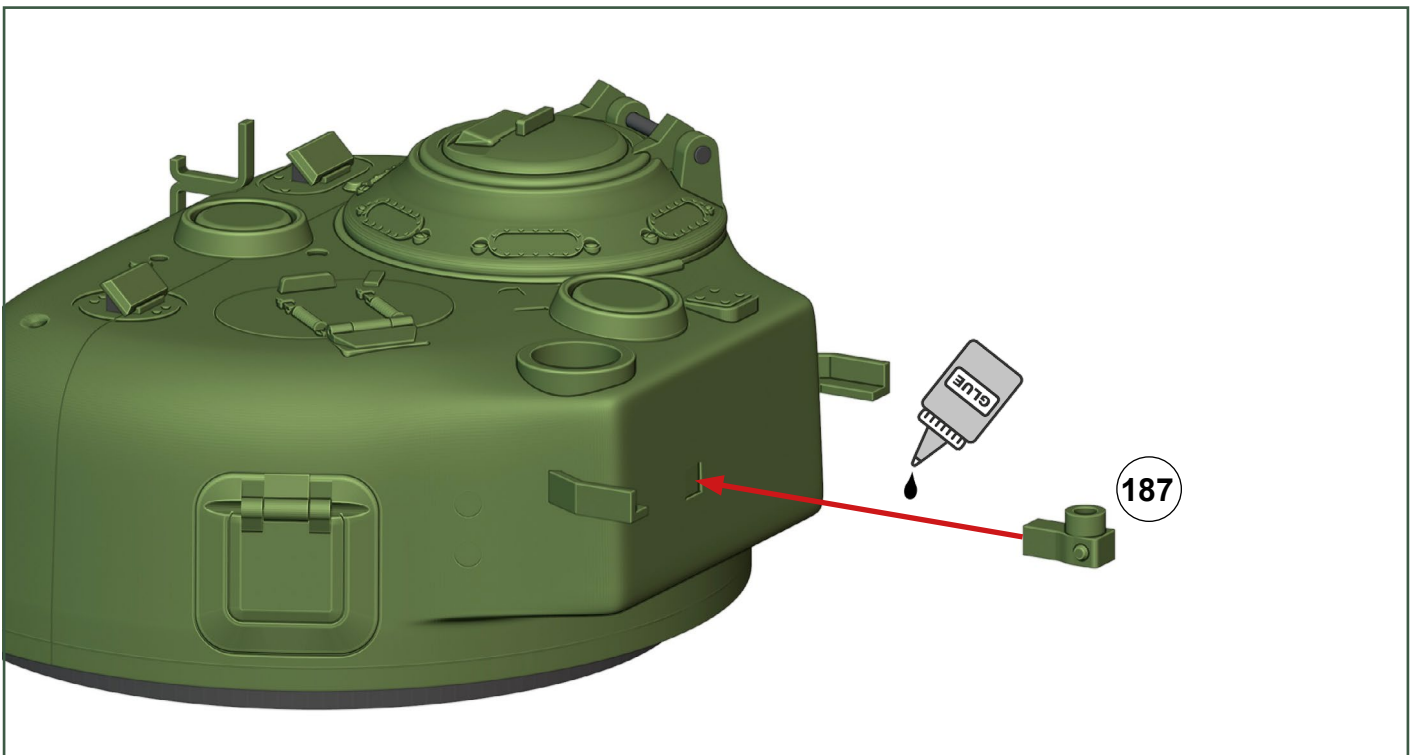

M4A3 Sherman – Build Guide

Turret:

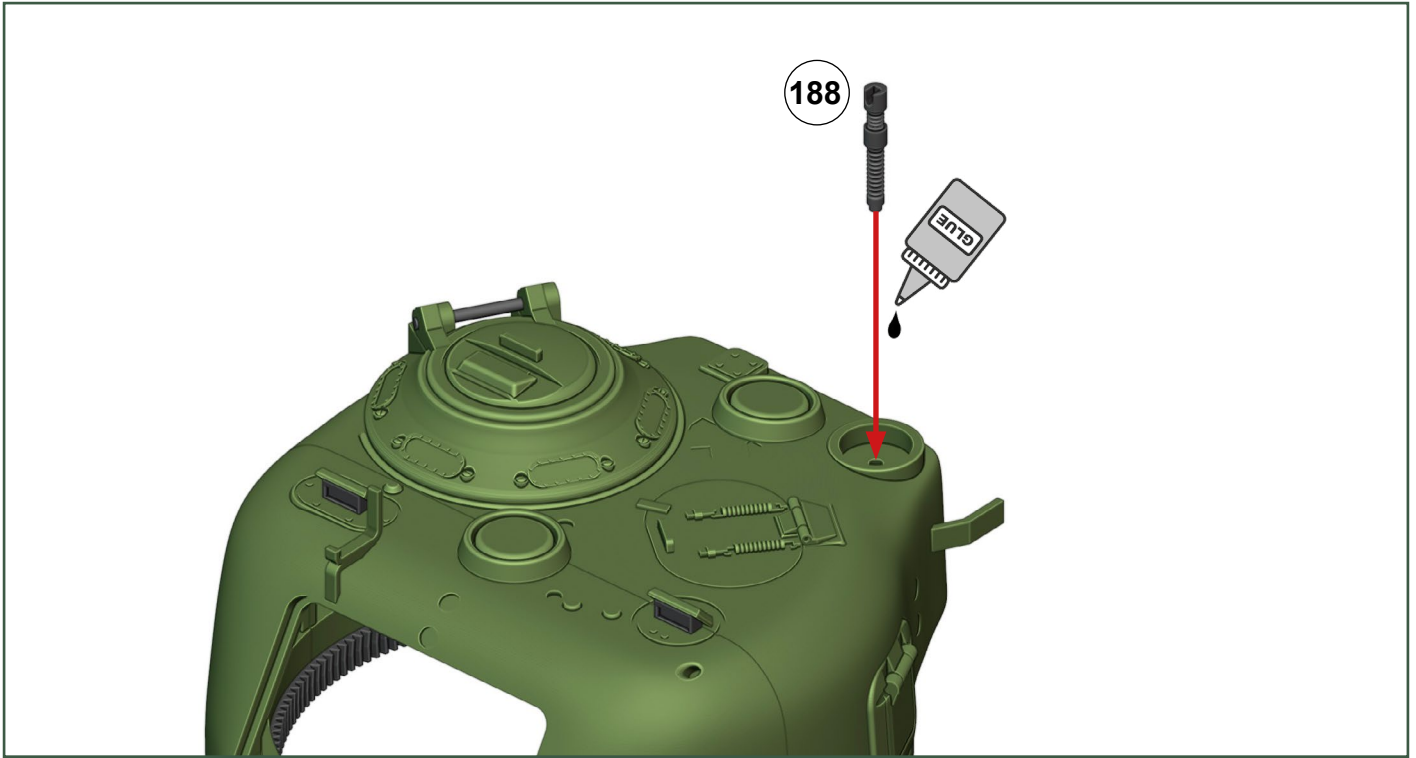

Turret:

2x

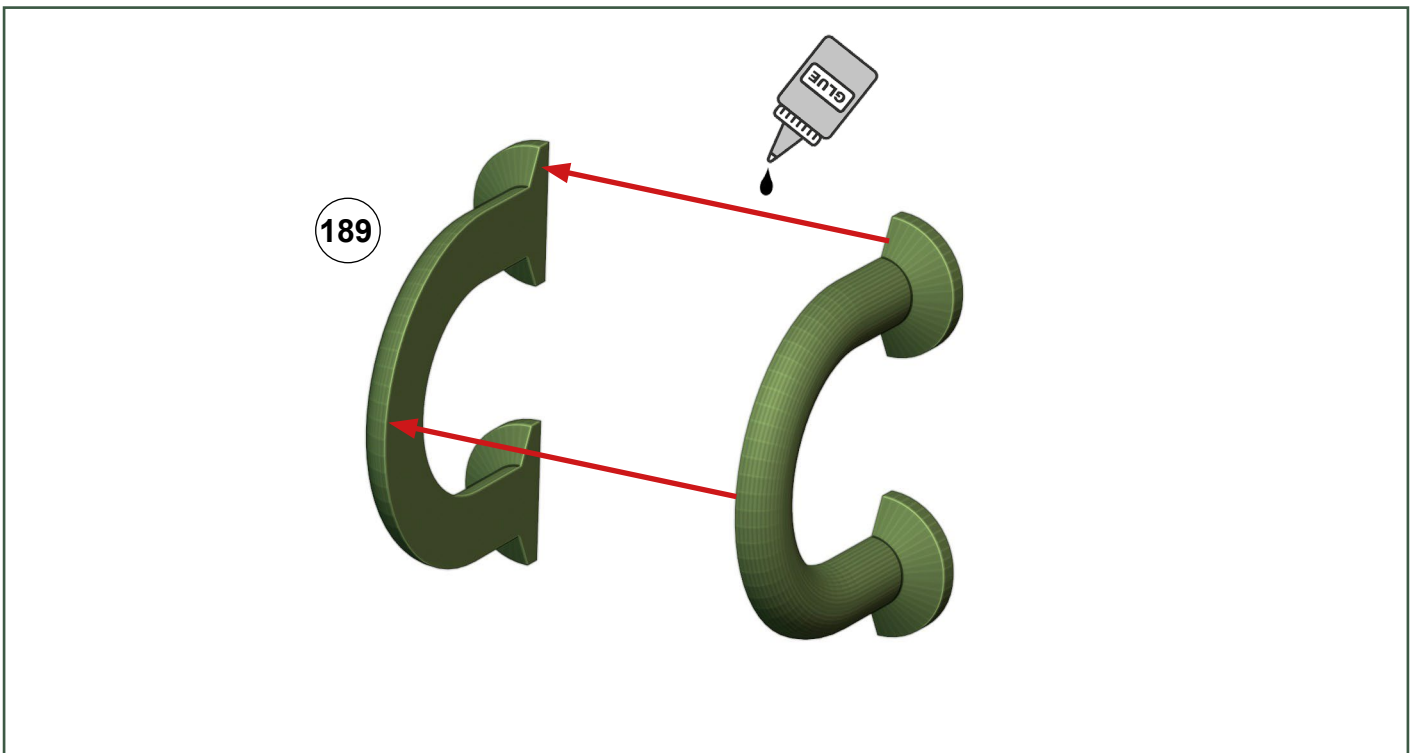

M4A3 Sherman – Build Guide

Turret:

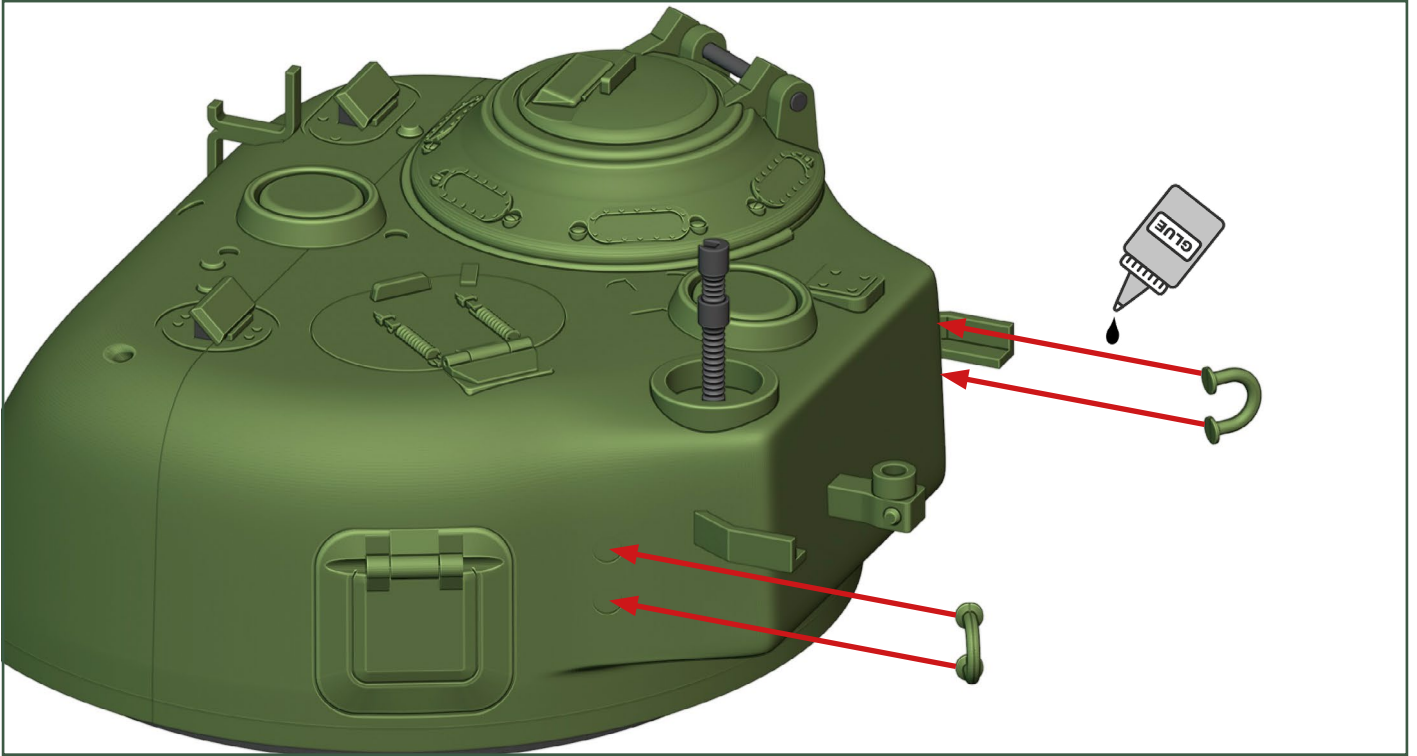

Turret:

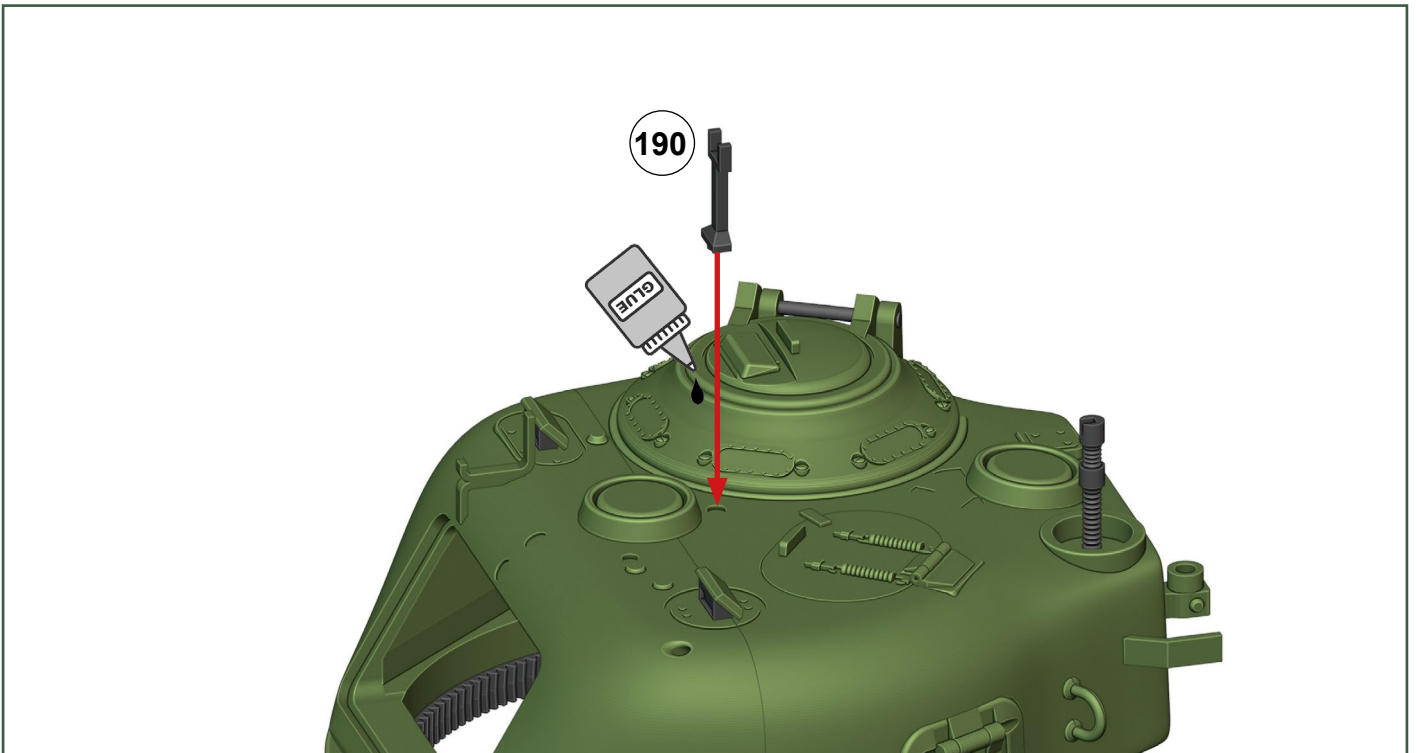

M4A3 Sherman – Build Guide

Turret:

LED 5 mm (warm white)

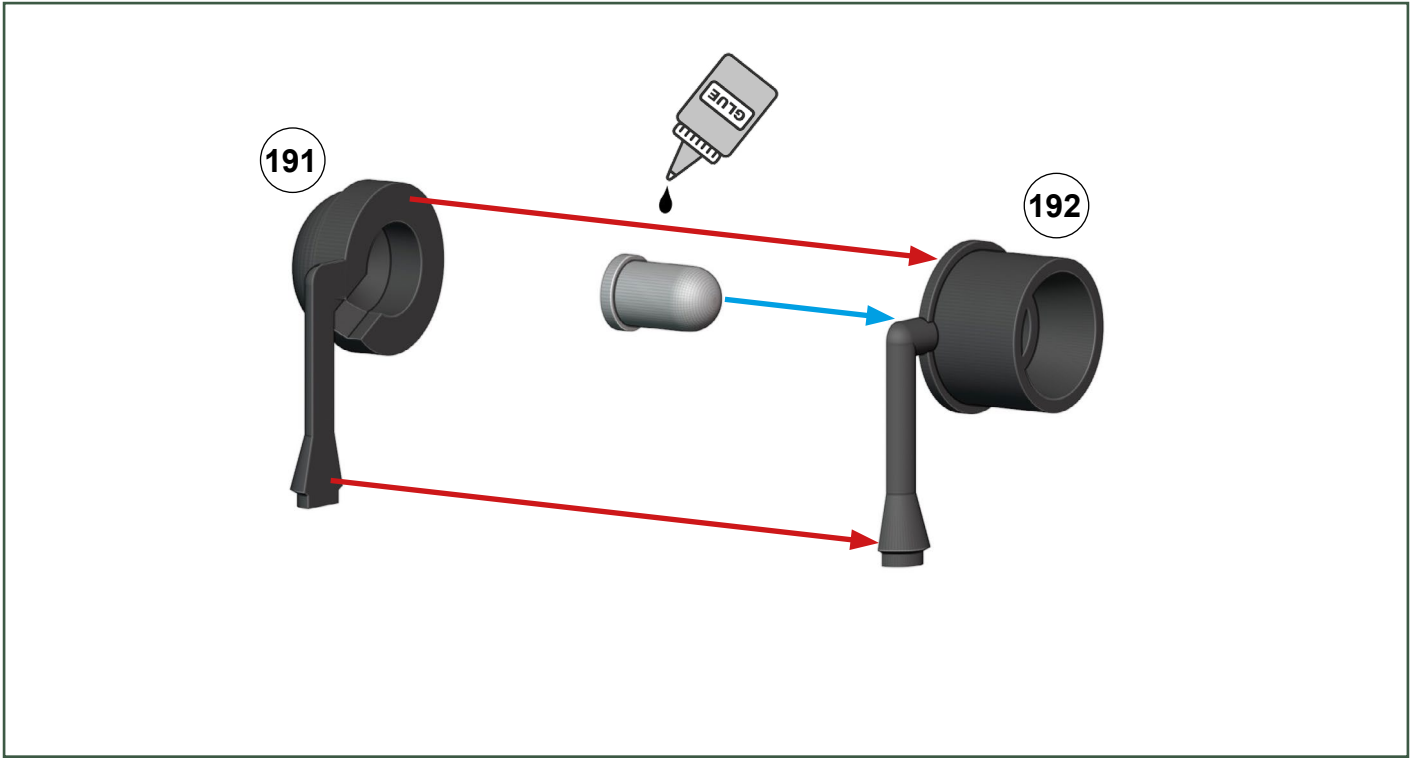

Turret:

Drill a hole in the turret for the LED cables.

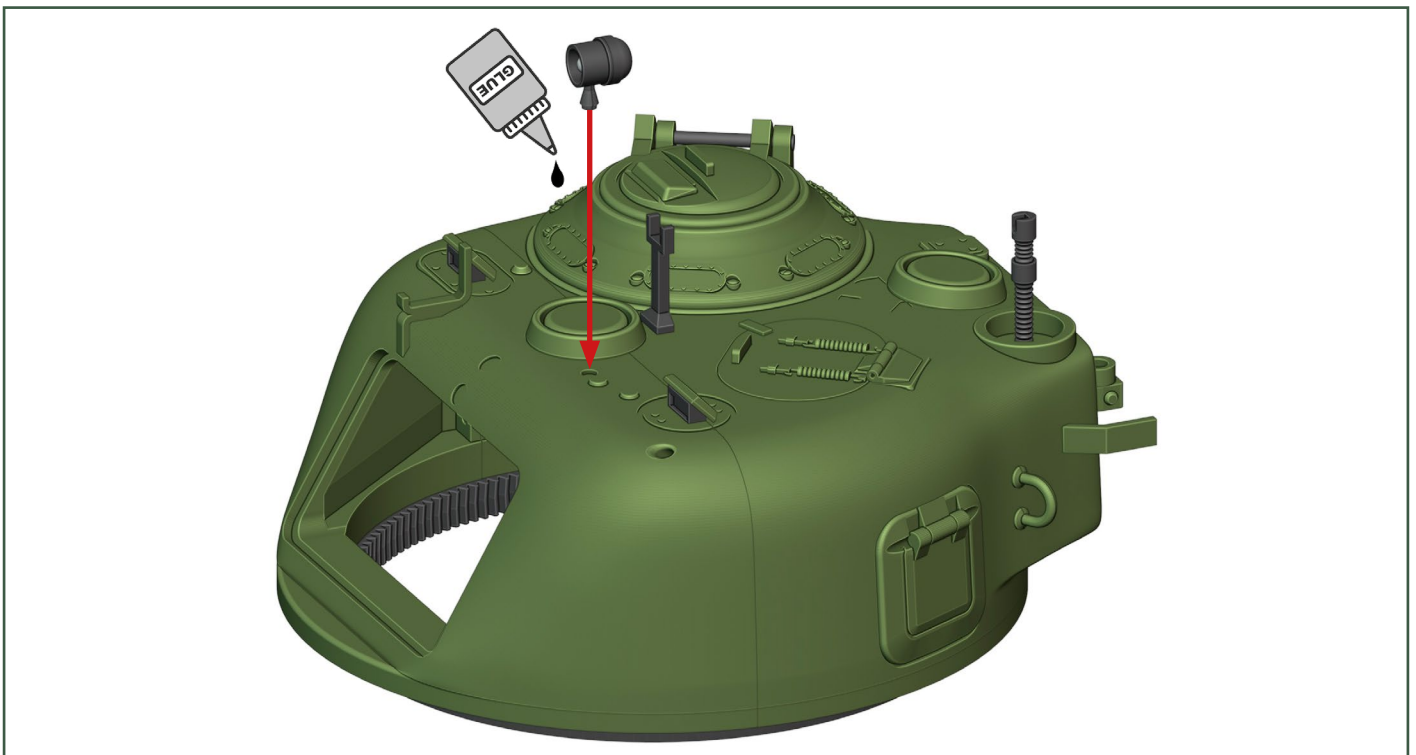

M4A3 Sherman – Build Guide

Turret:

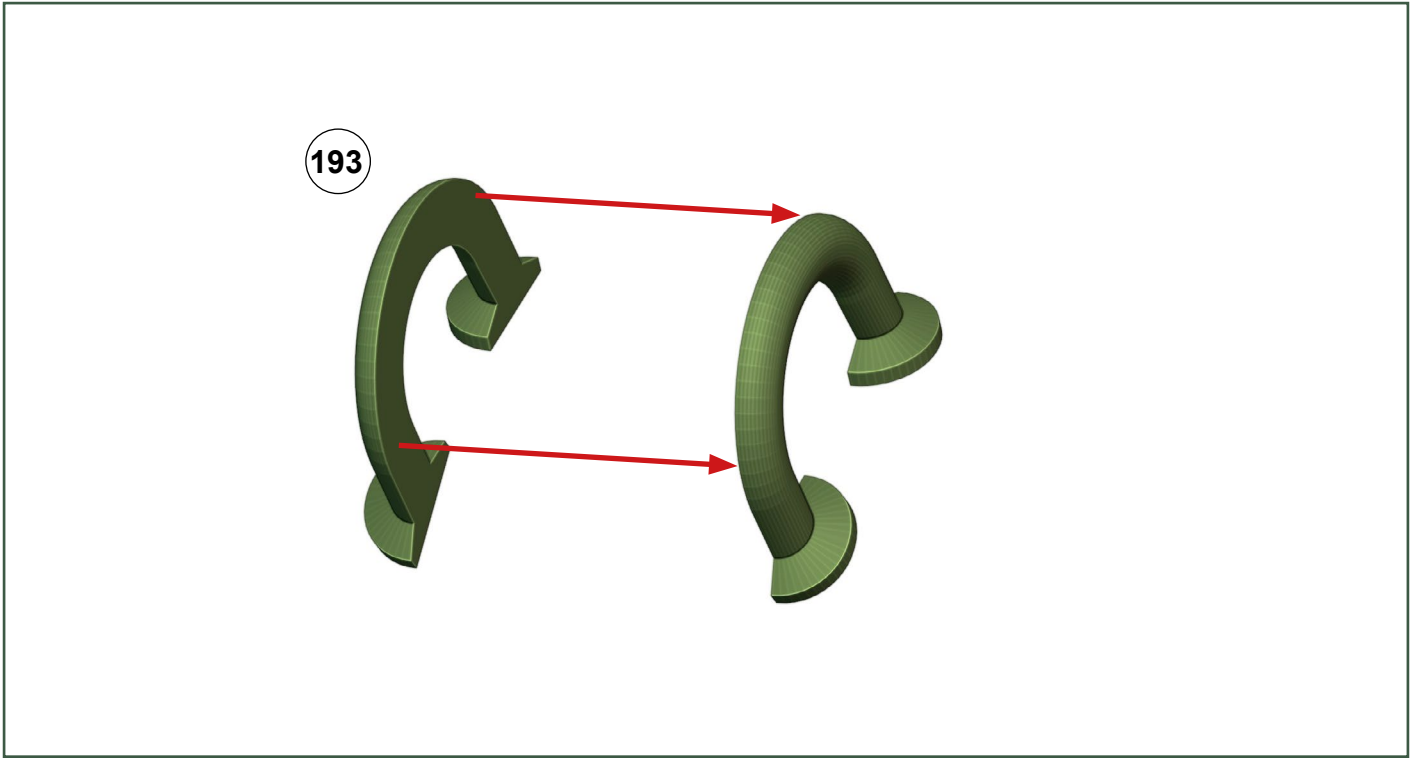

Turret:

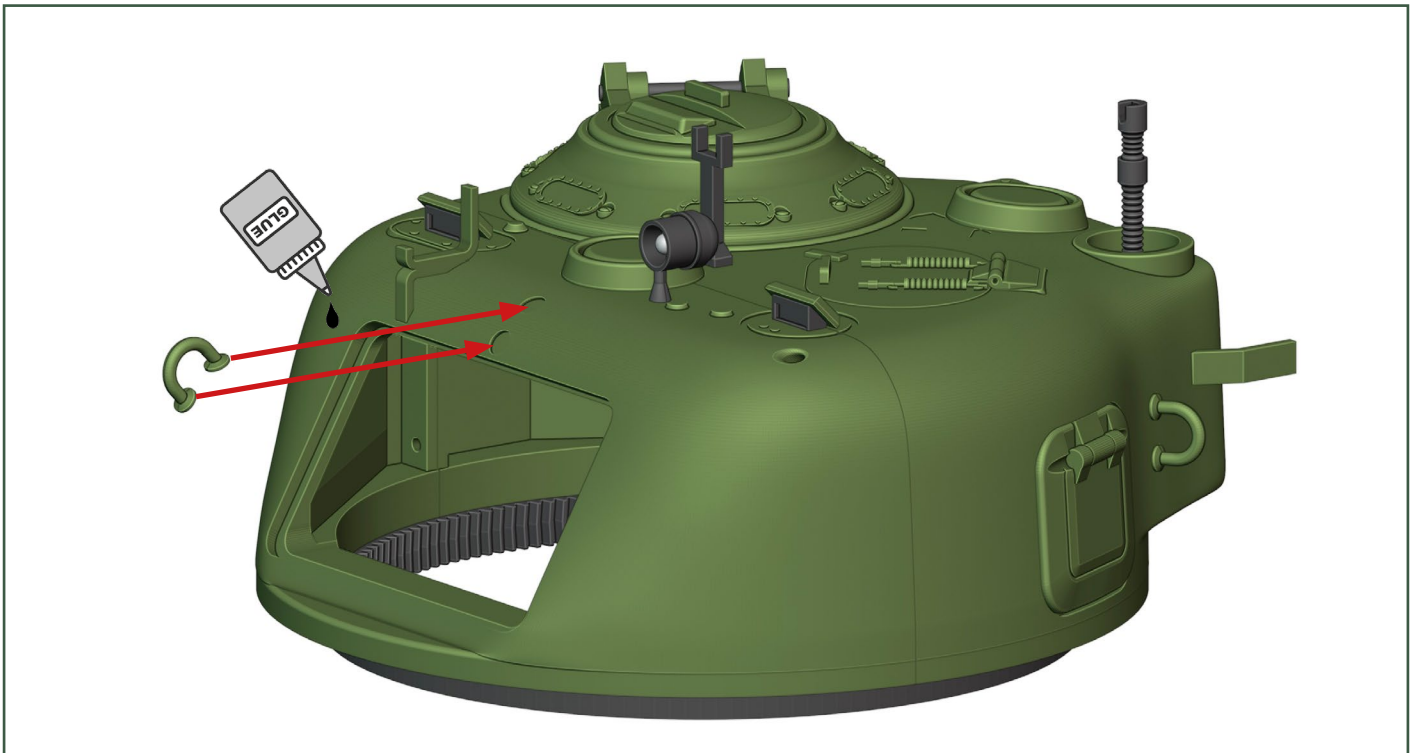

M4A3 Sherman - Build Guide

Turret:

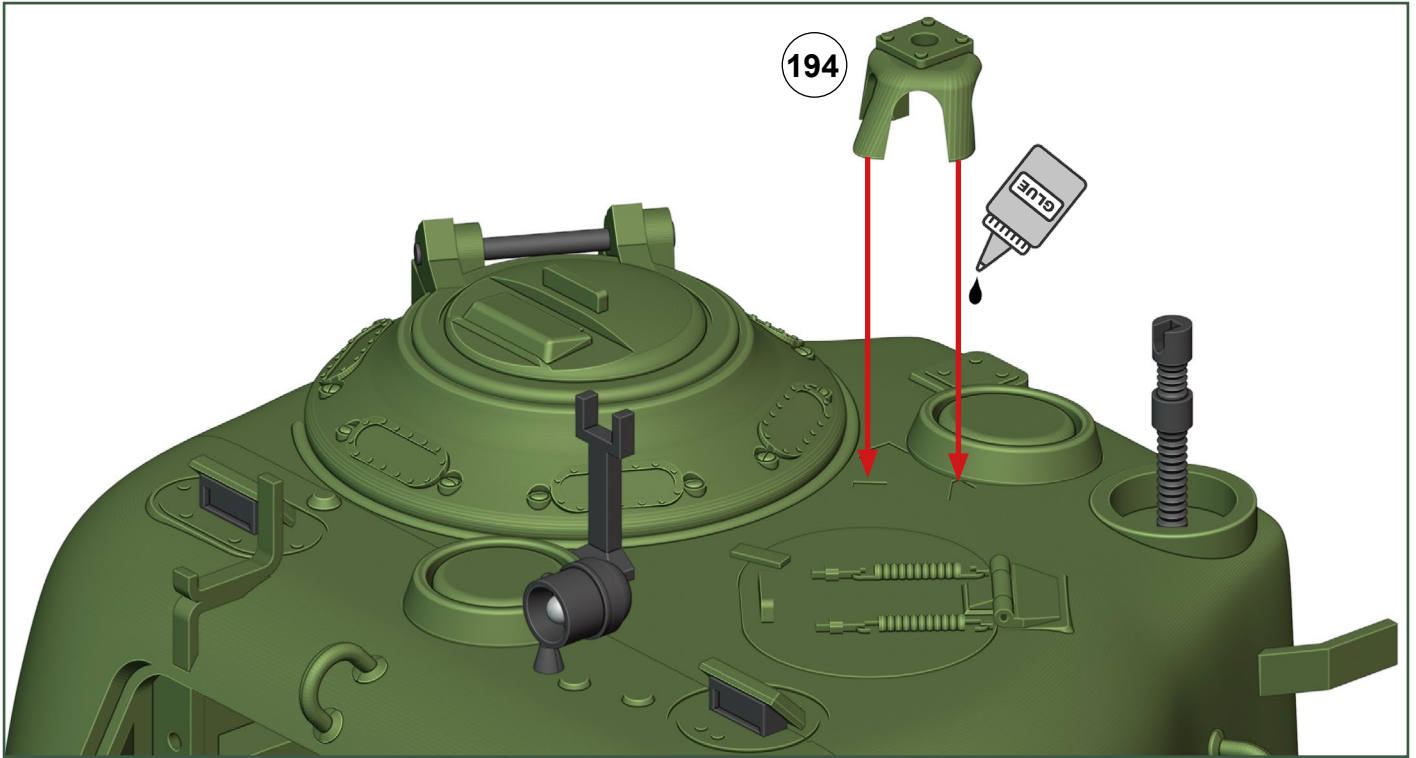

Turret:

2x M3 screw 12 mm

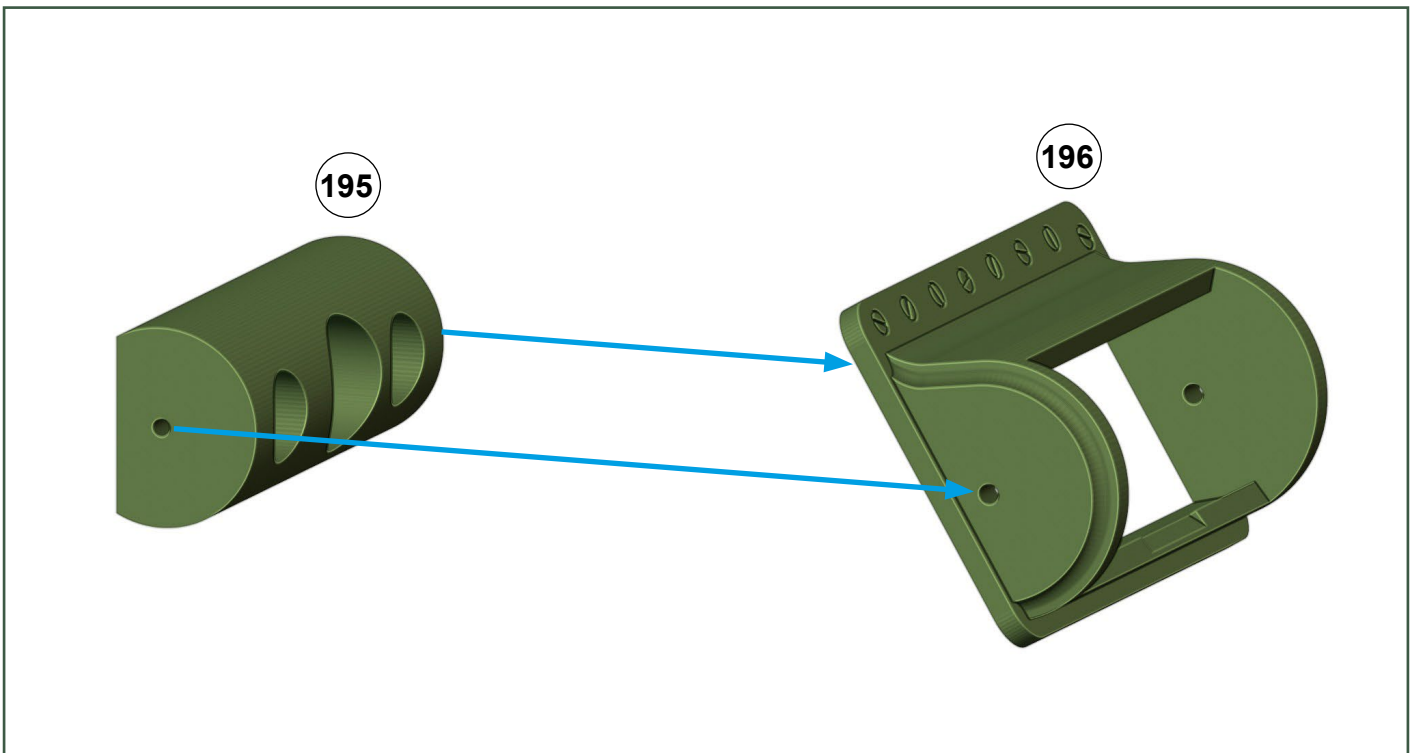

M4A3 Sherman – Build Guide

Turret:

Remove support from part 197.

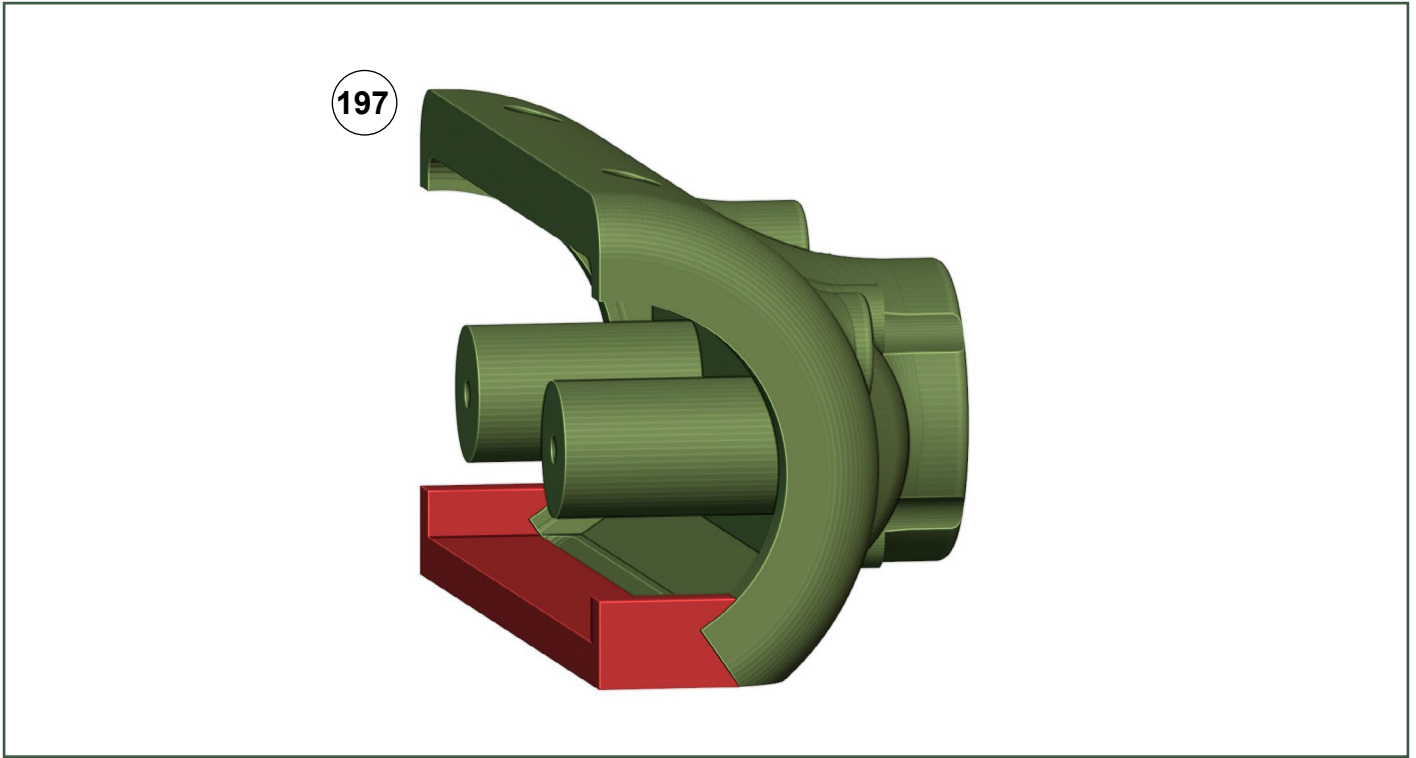

Turret:

Clean up the holes.

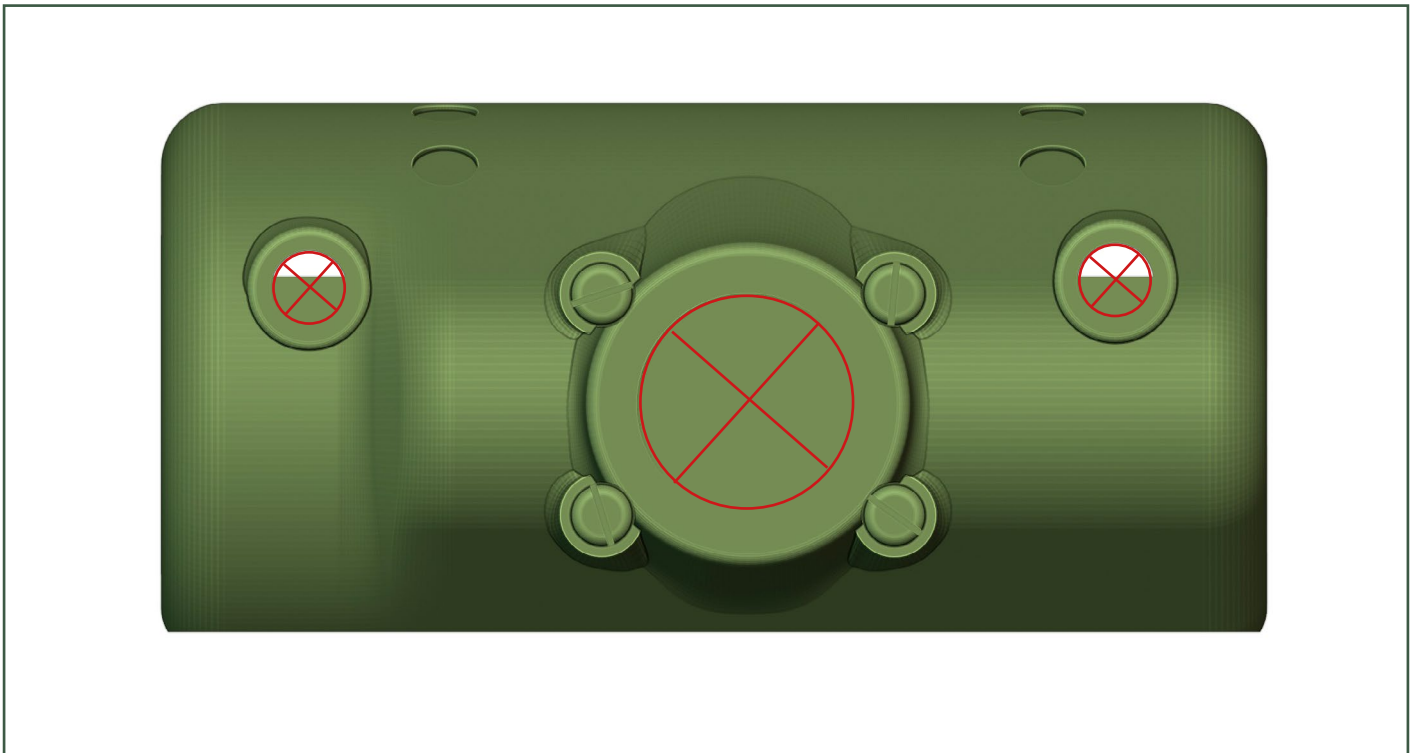

M4A3 Sherman - Build Guide

Turret:

M3 screw 12 mm

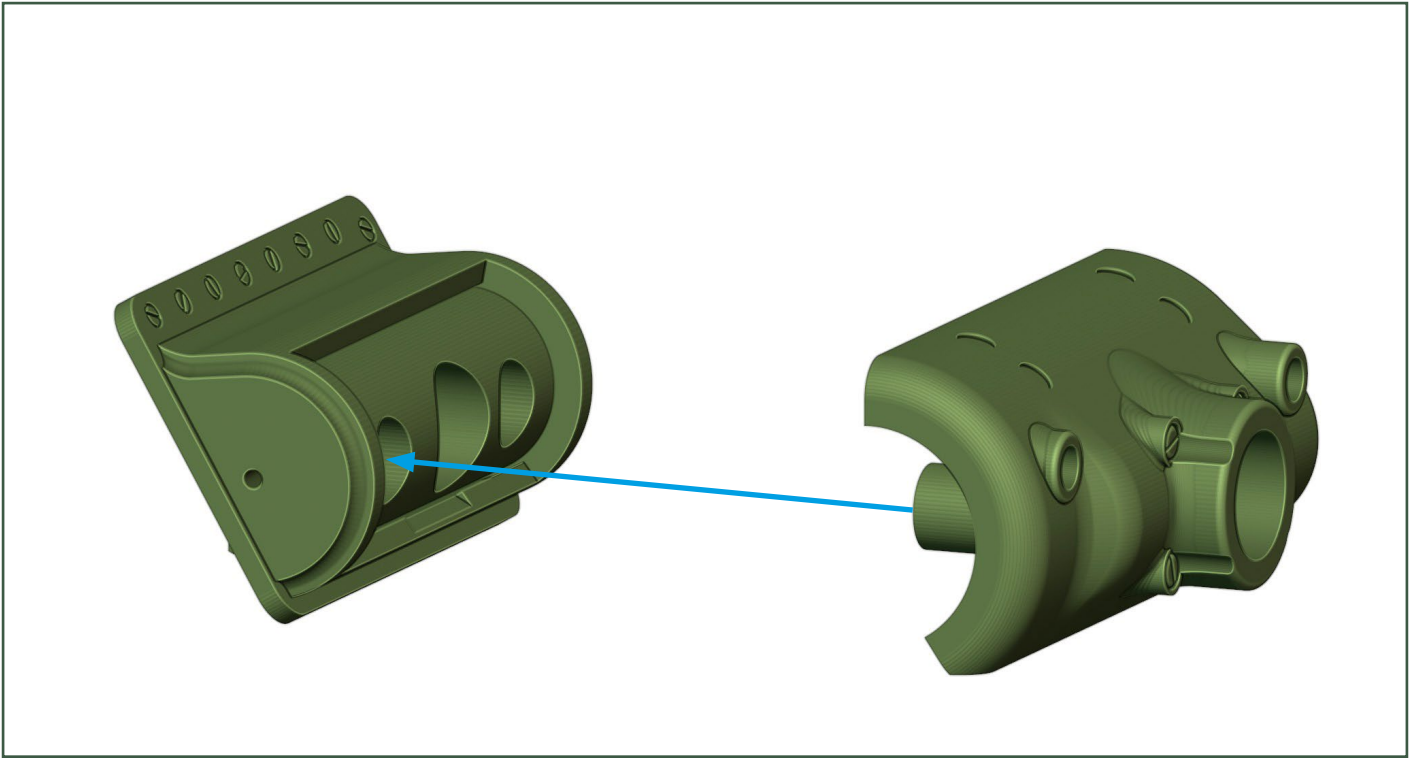

Turret:

2x M3 screw 8 mm, M3 screw 12 mm (on left)

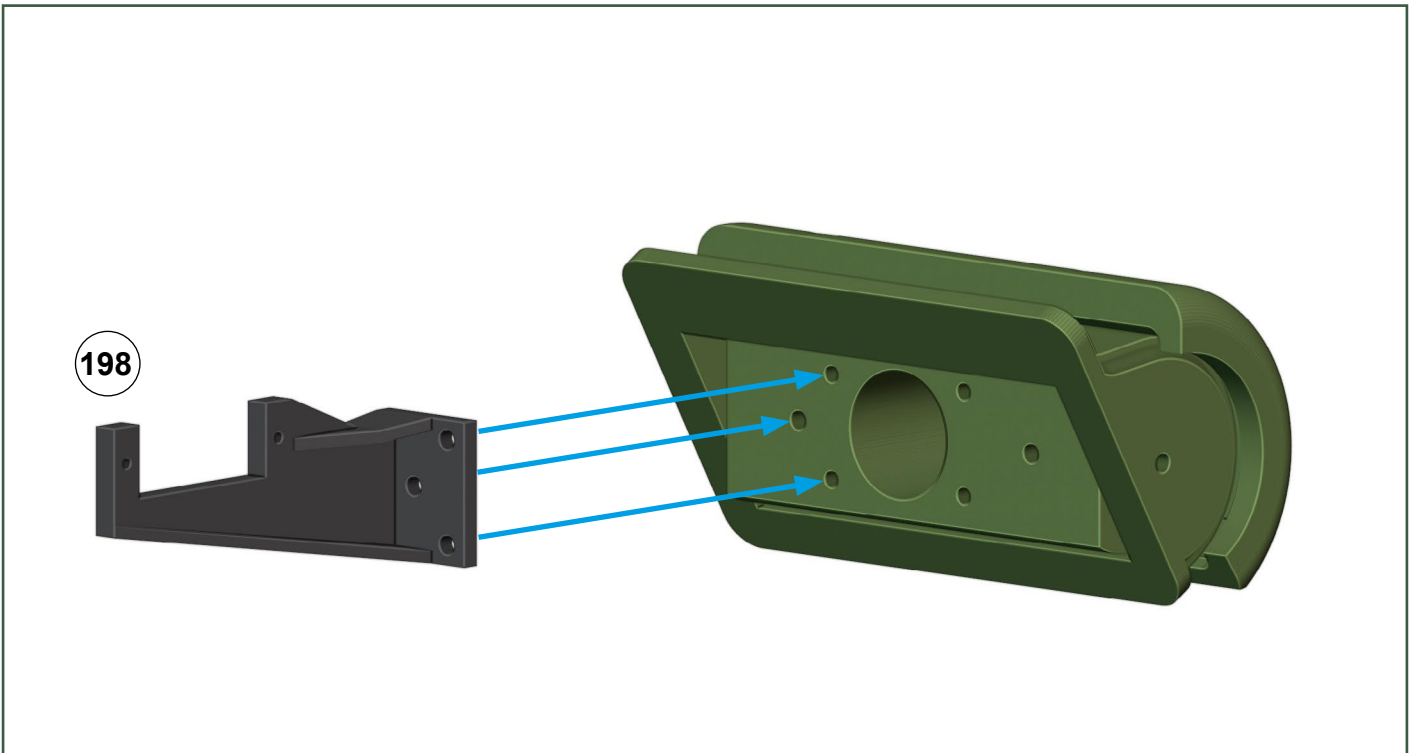

M4A3 Sherman – Build Guide

Turret:

2x M3 screw 8 mm

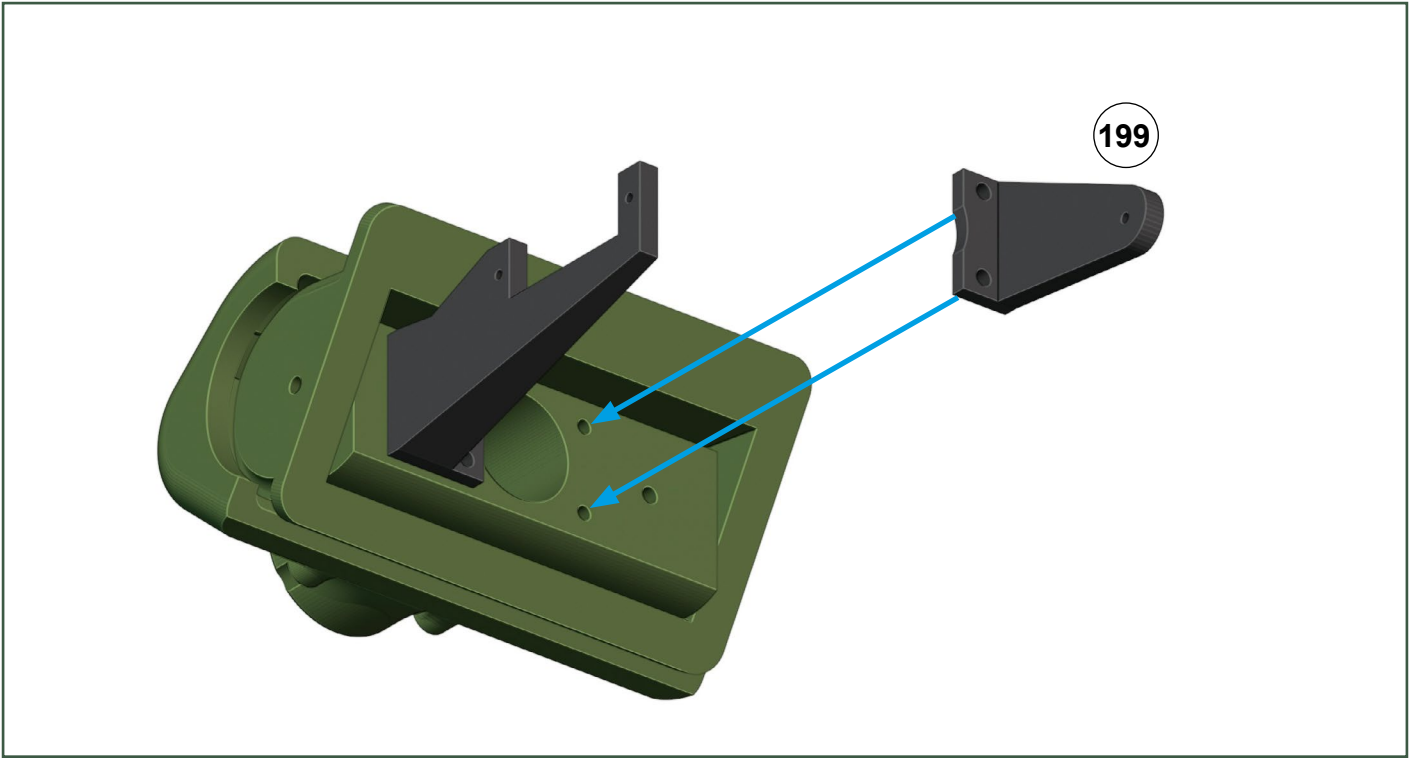

Turret:

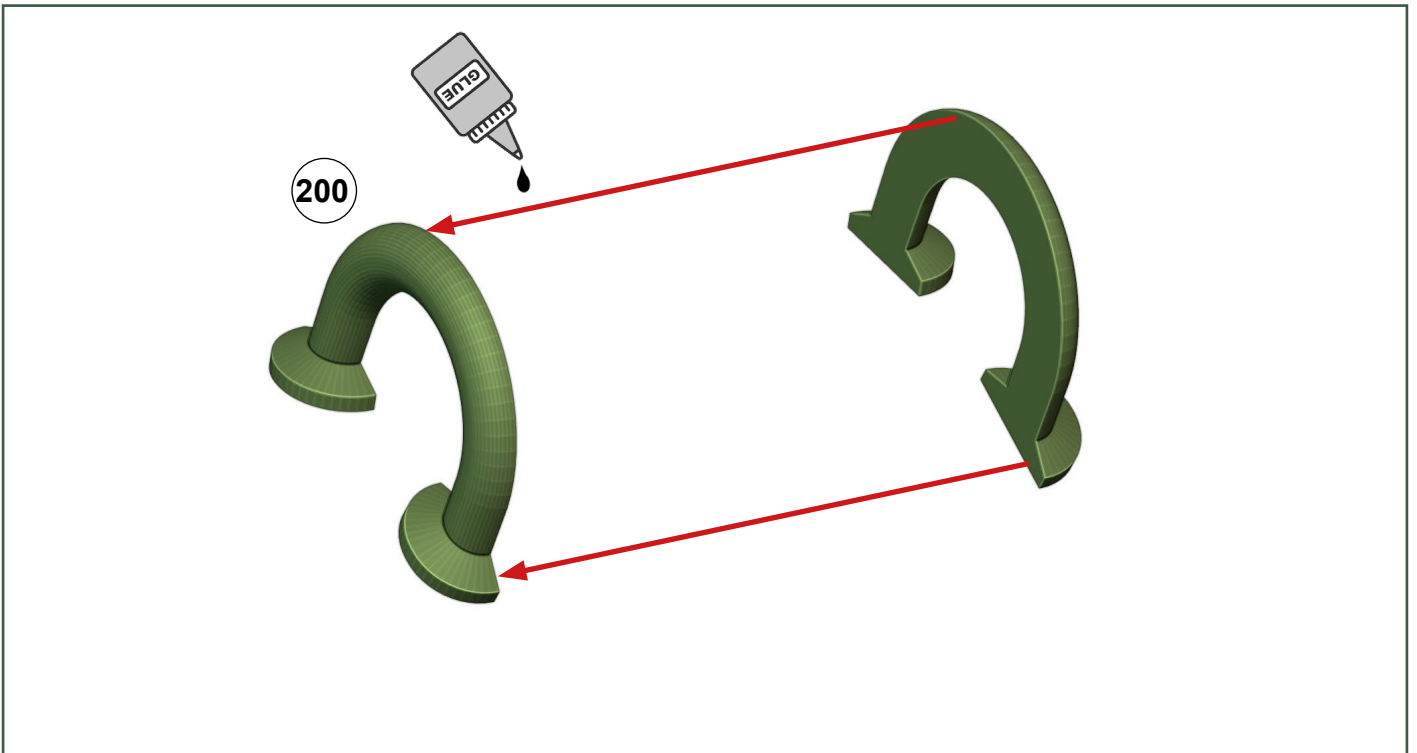

M4A3 Sherman - Build Guide

Turret:

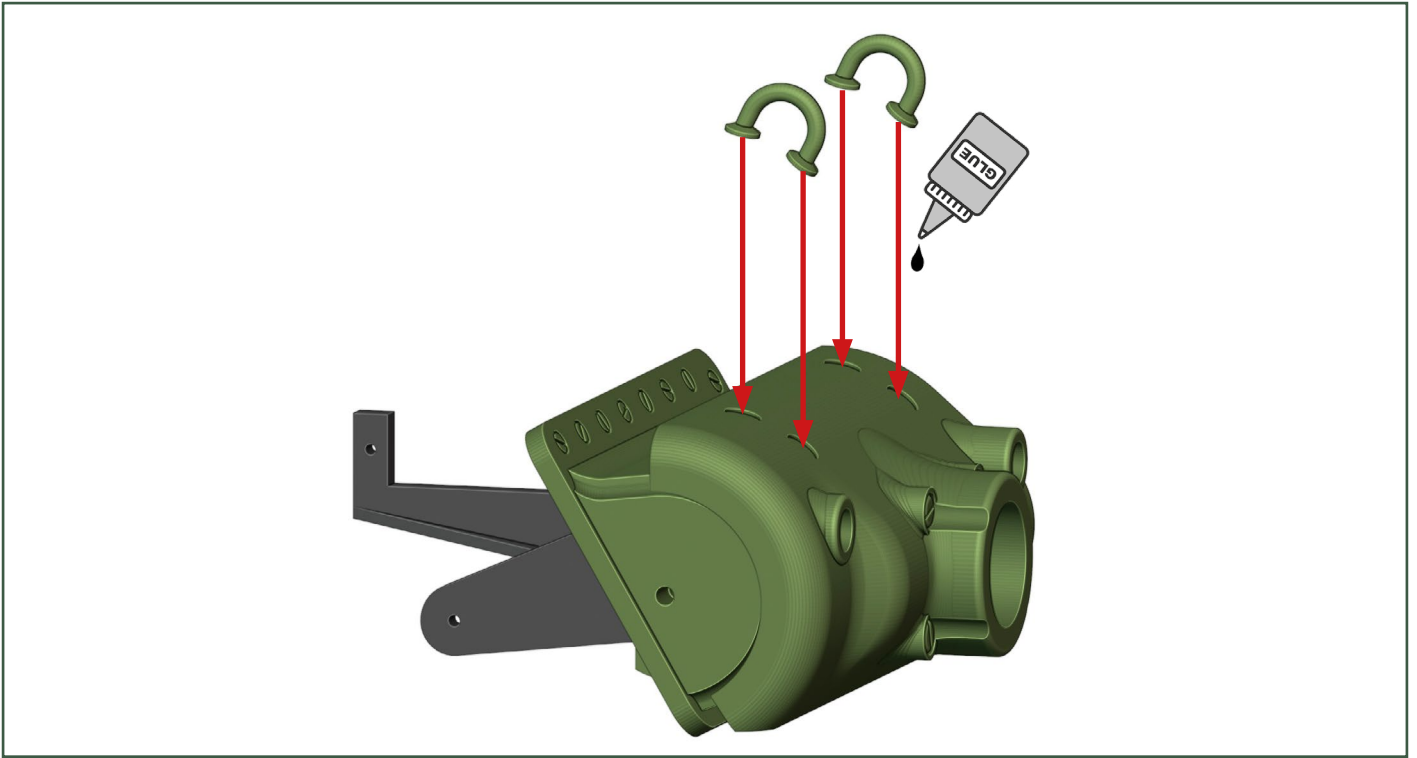

Turret:

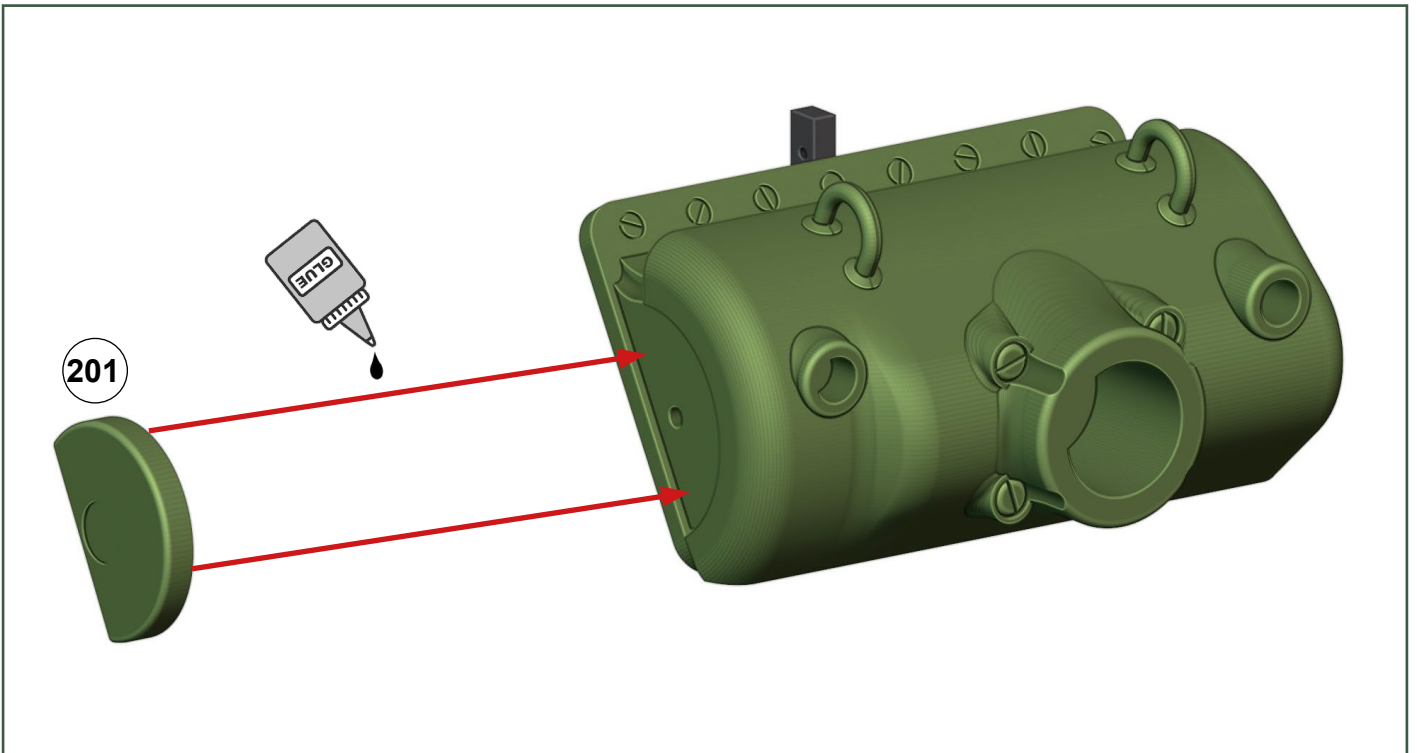

M4A3 Sherman – Build Guide

Turret:

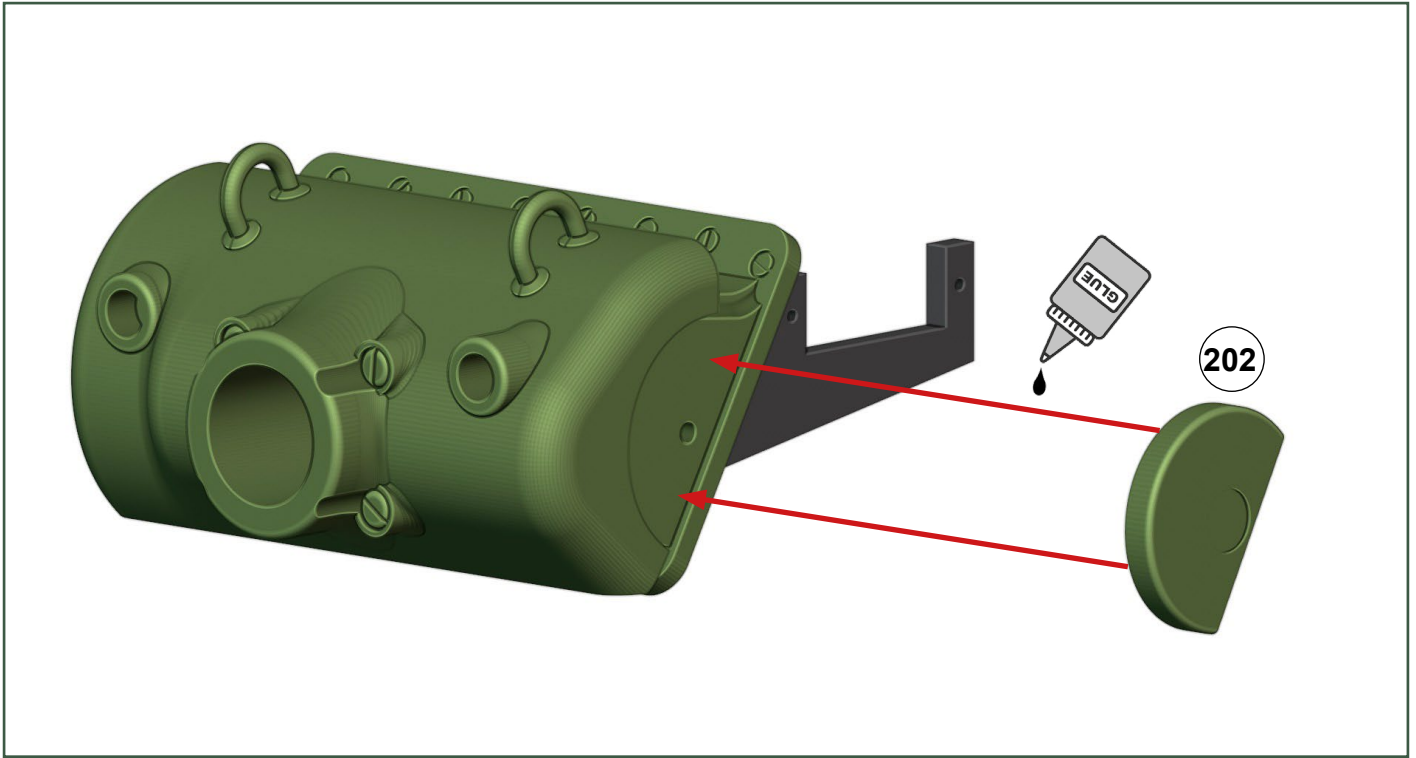

Turret:

2x M2 screw 8 mm with washer, high speed mini servo (size like HS-81)

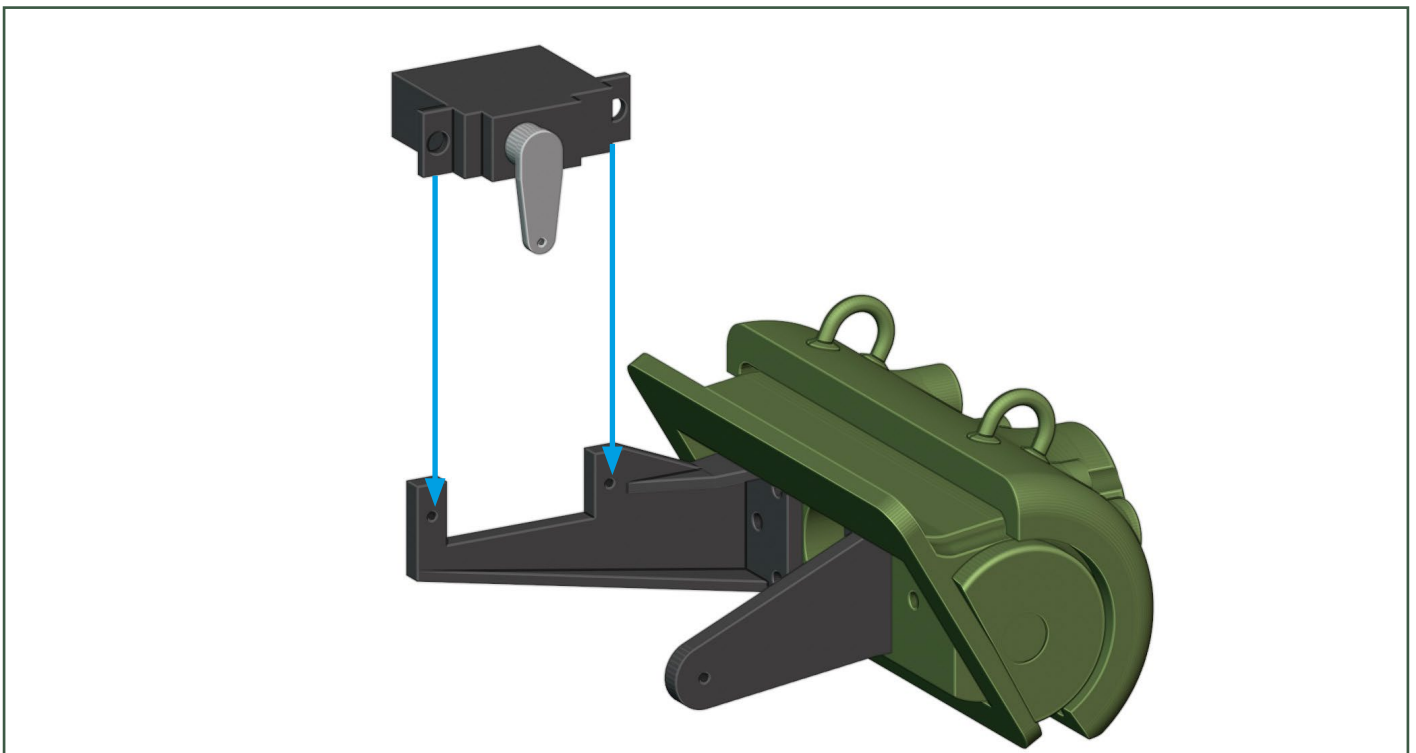

M4A3 Sherman - Build Guide

Turret:

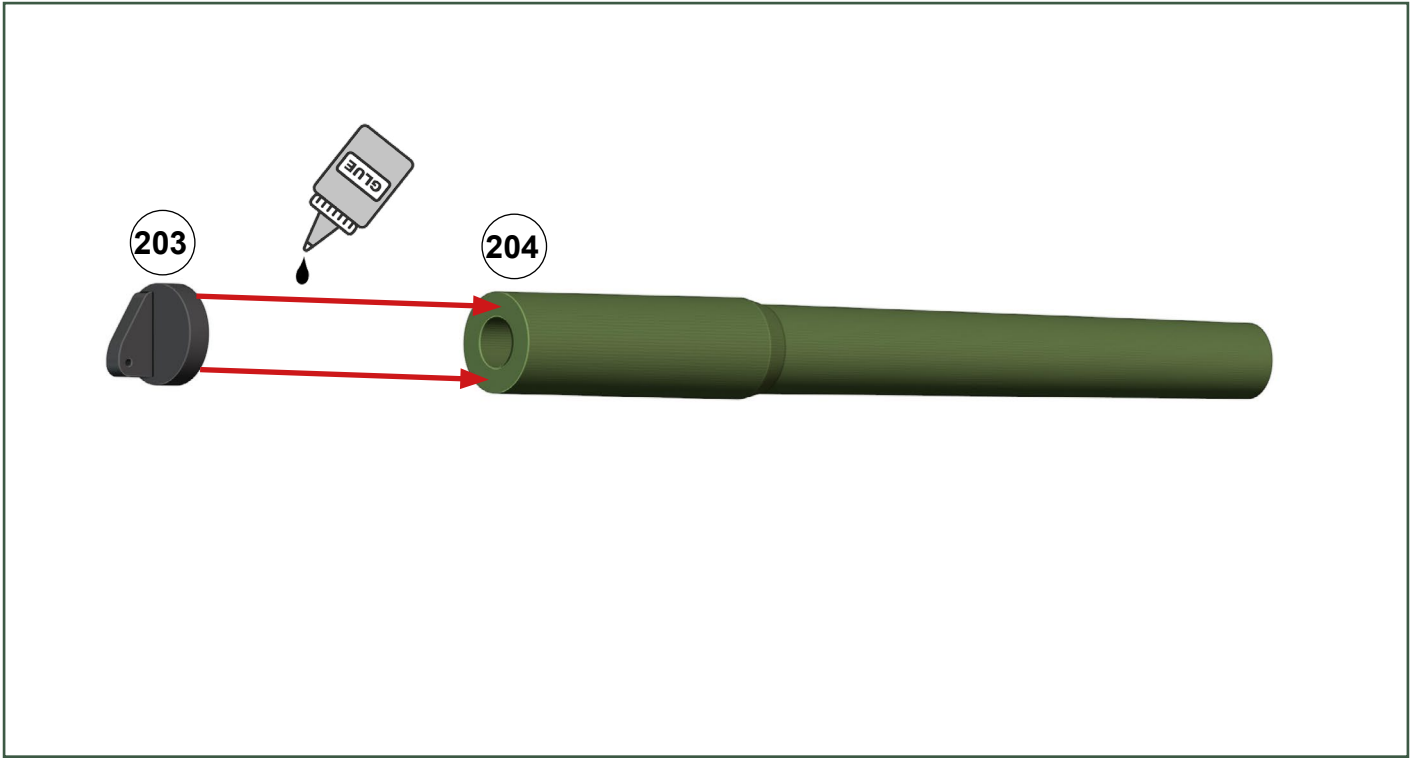

Turret:

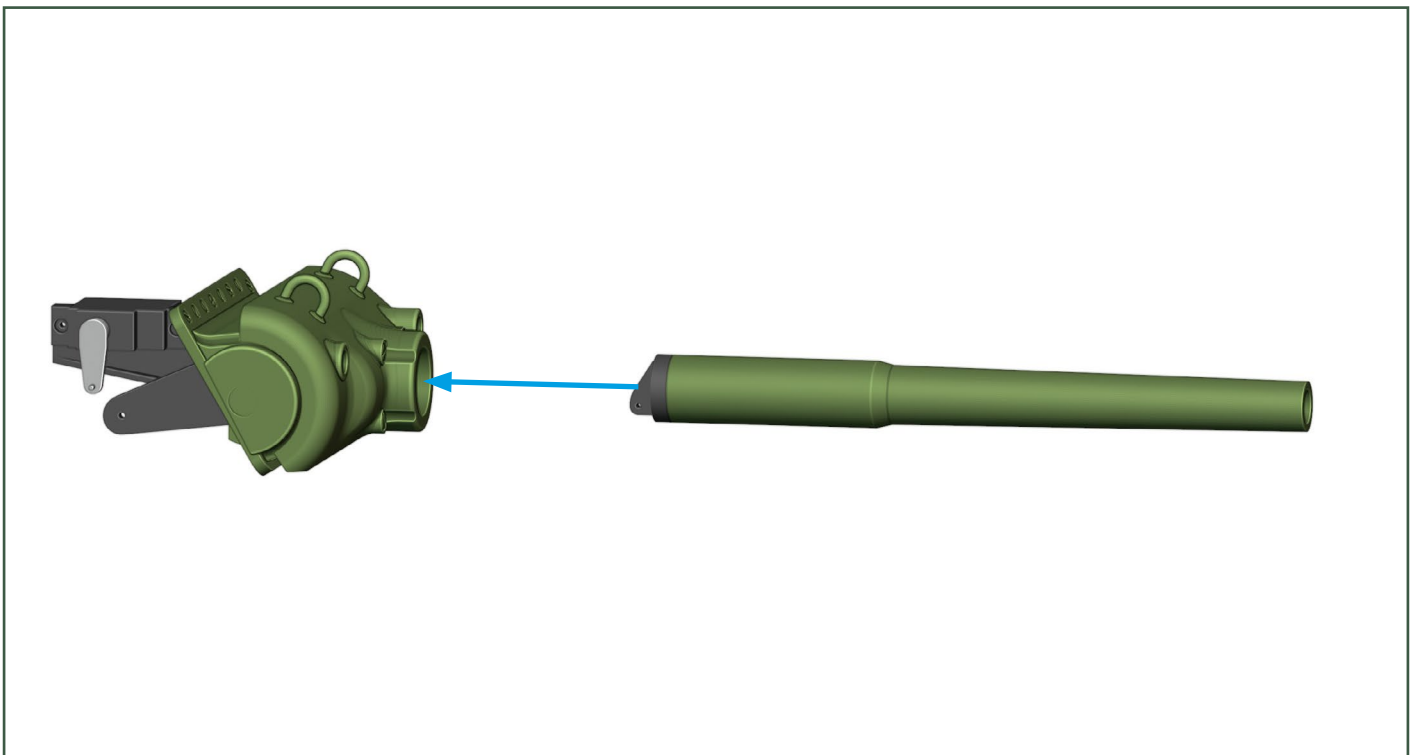

M4A3 Sherman – Build Guide

Turret:

make the link with length 36 mm

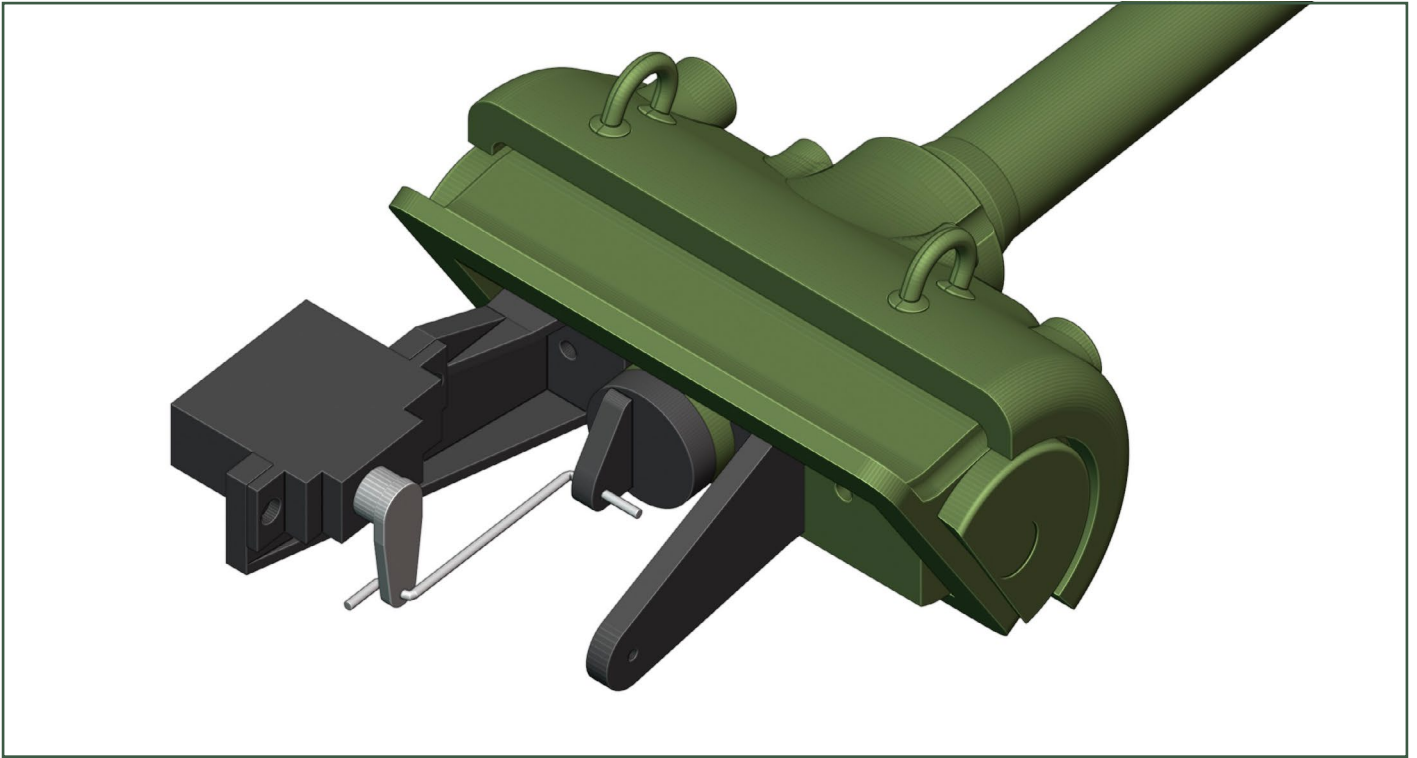

Turret:

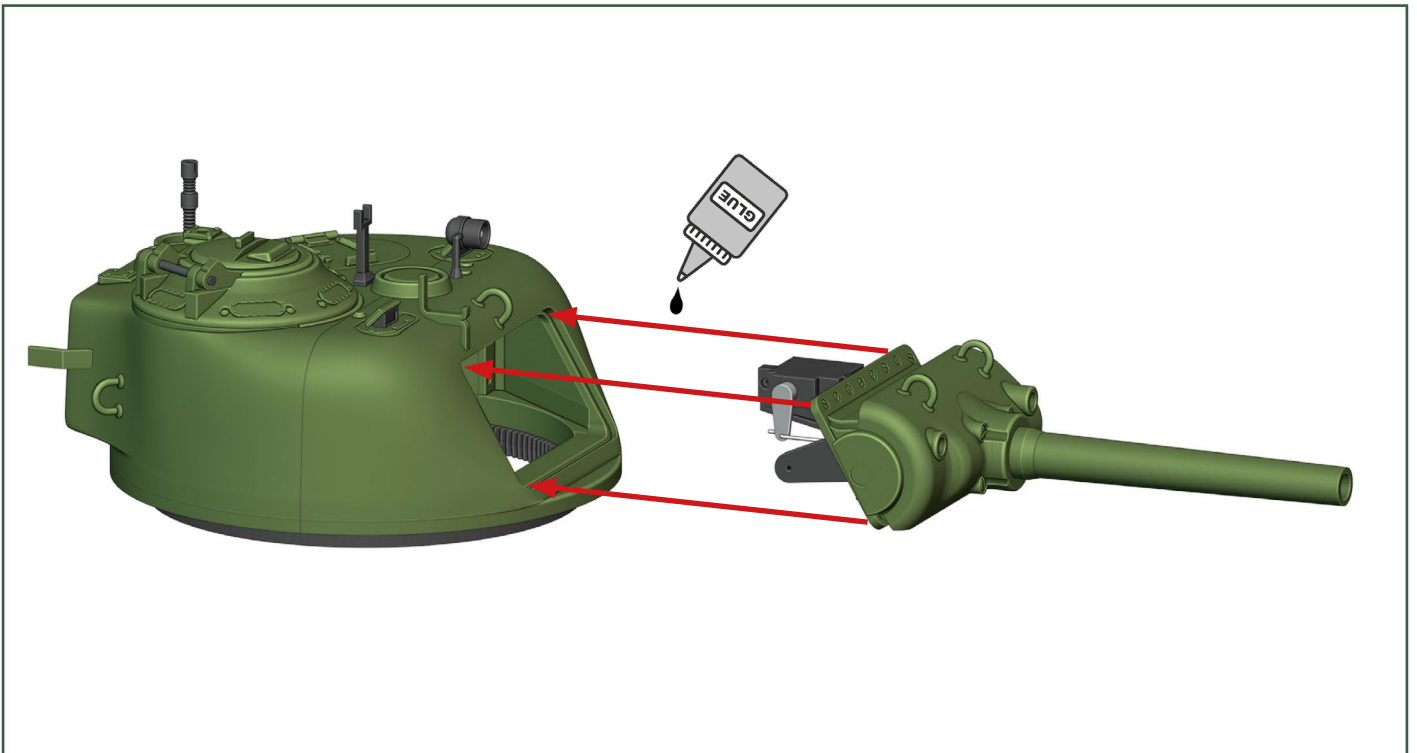

M4A3 Sherman – Build Guide

Turret:

4x M2 screw 8 mm with washer, standard servo

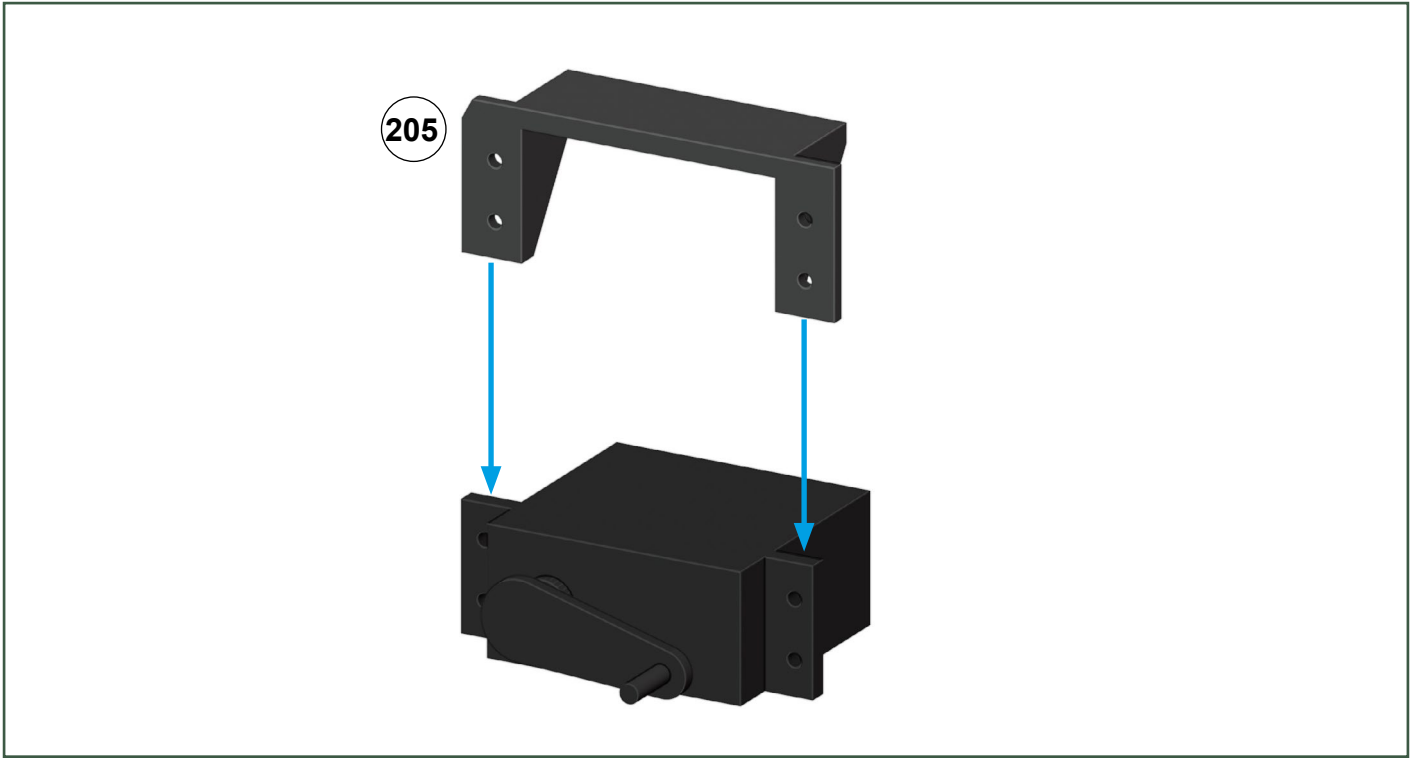

Turret:

maximum servo lever deflections $\pm 45^\circ$, length of servo lever 22-23 mm

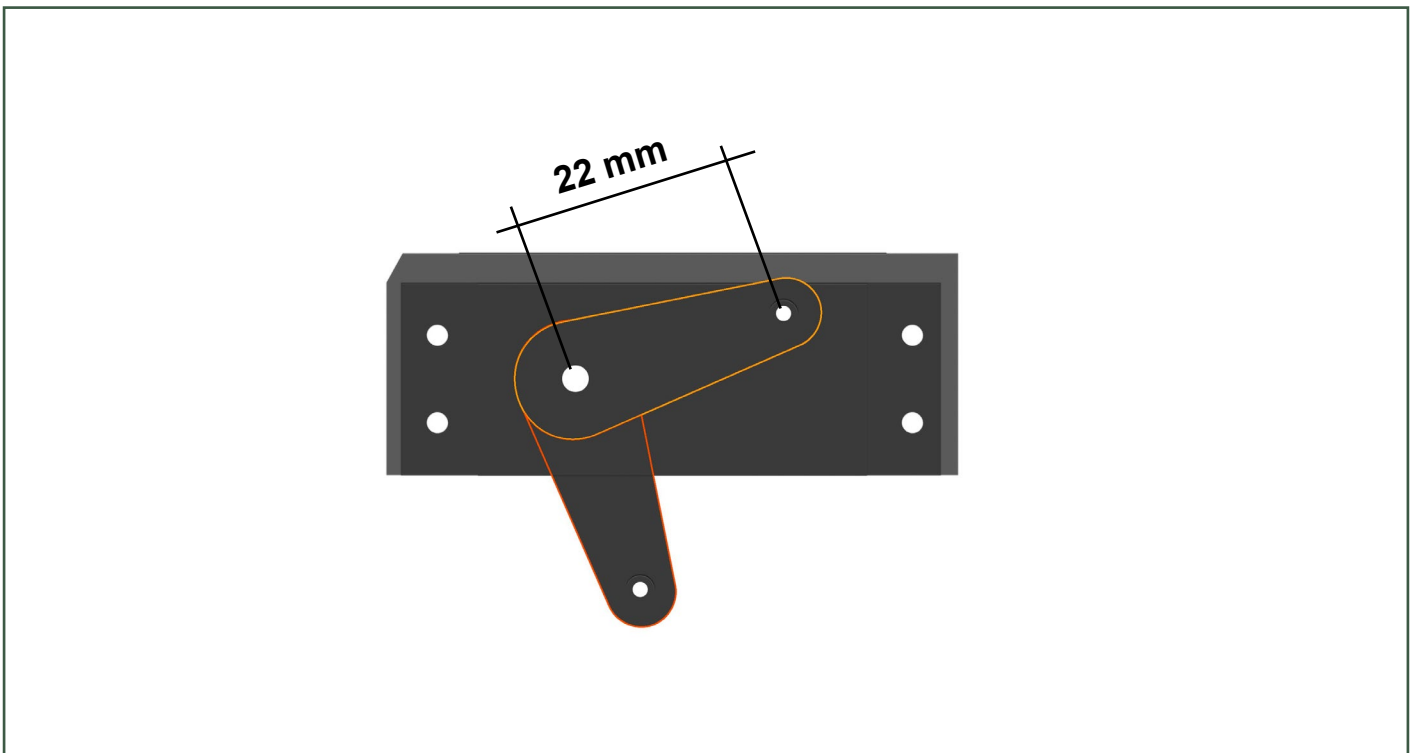

M4A3 Sherman – Build Guide

Turret:

Glue the servo to the position shown in the following picture.

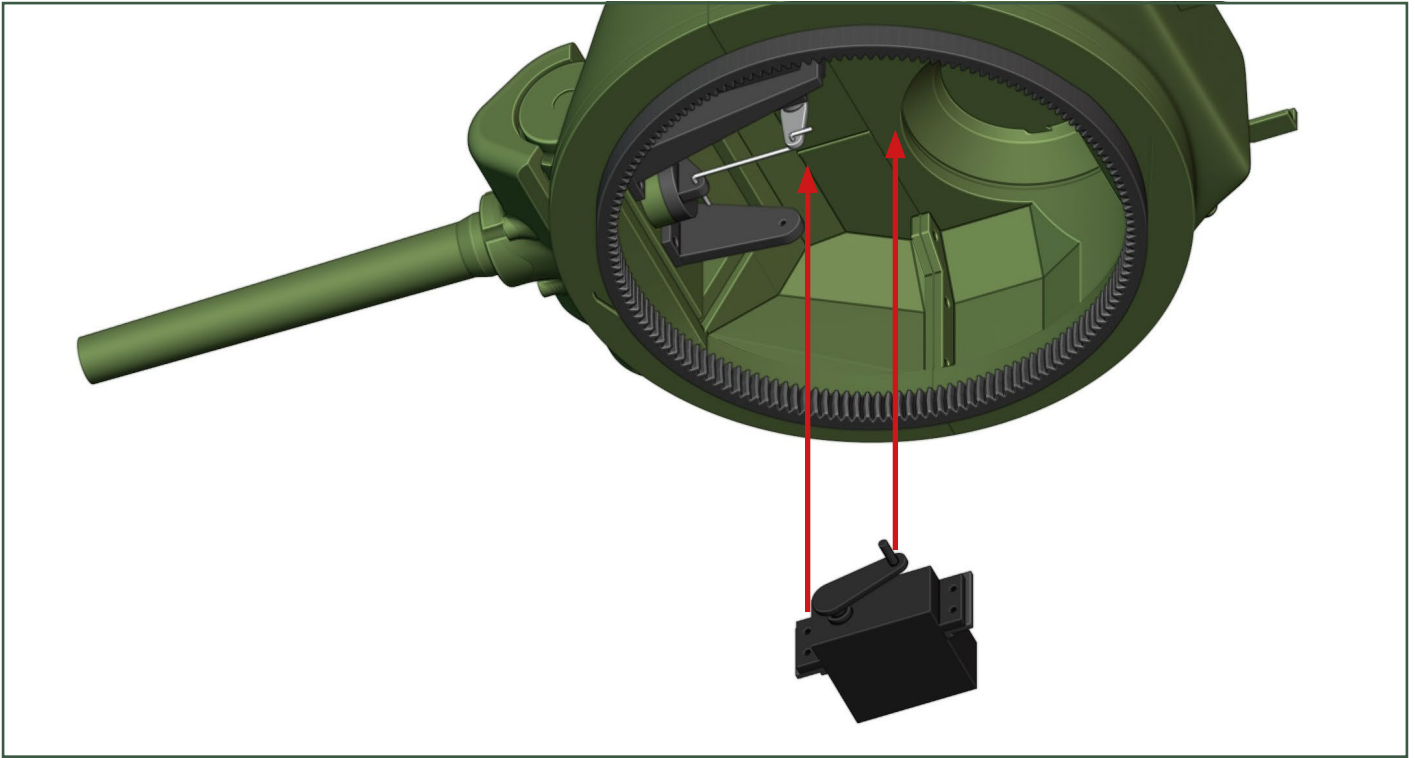

Turret:

Wire coupling approx. 49 mm. M2 ball joints can also be used.

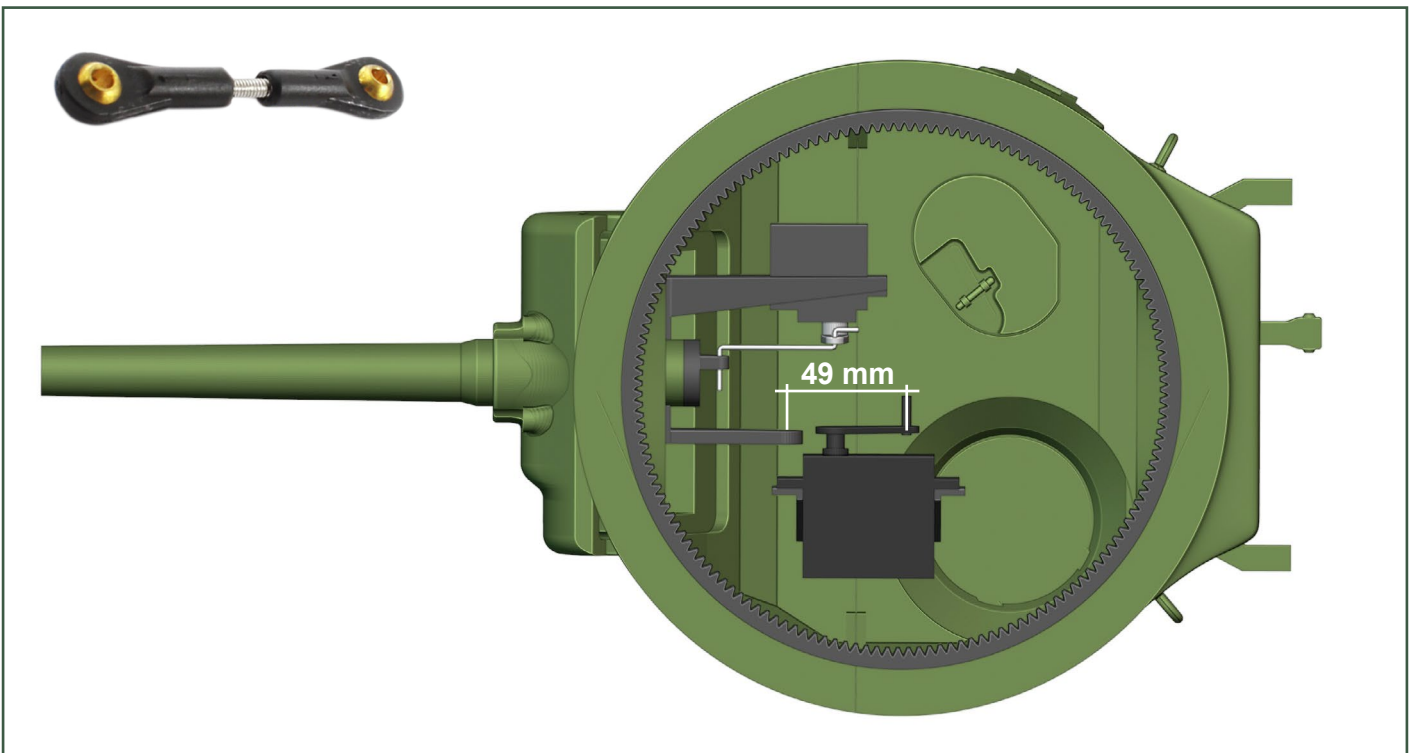

M4A3 Sherman - Build Guide

Turret:

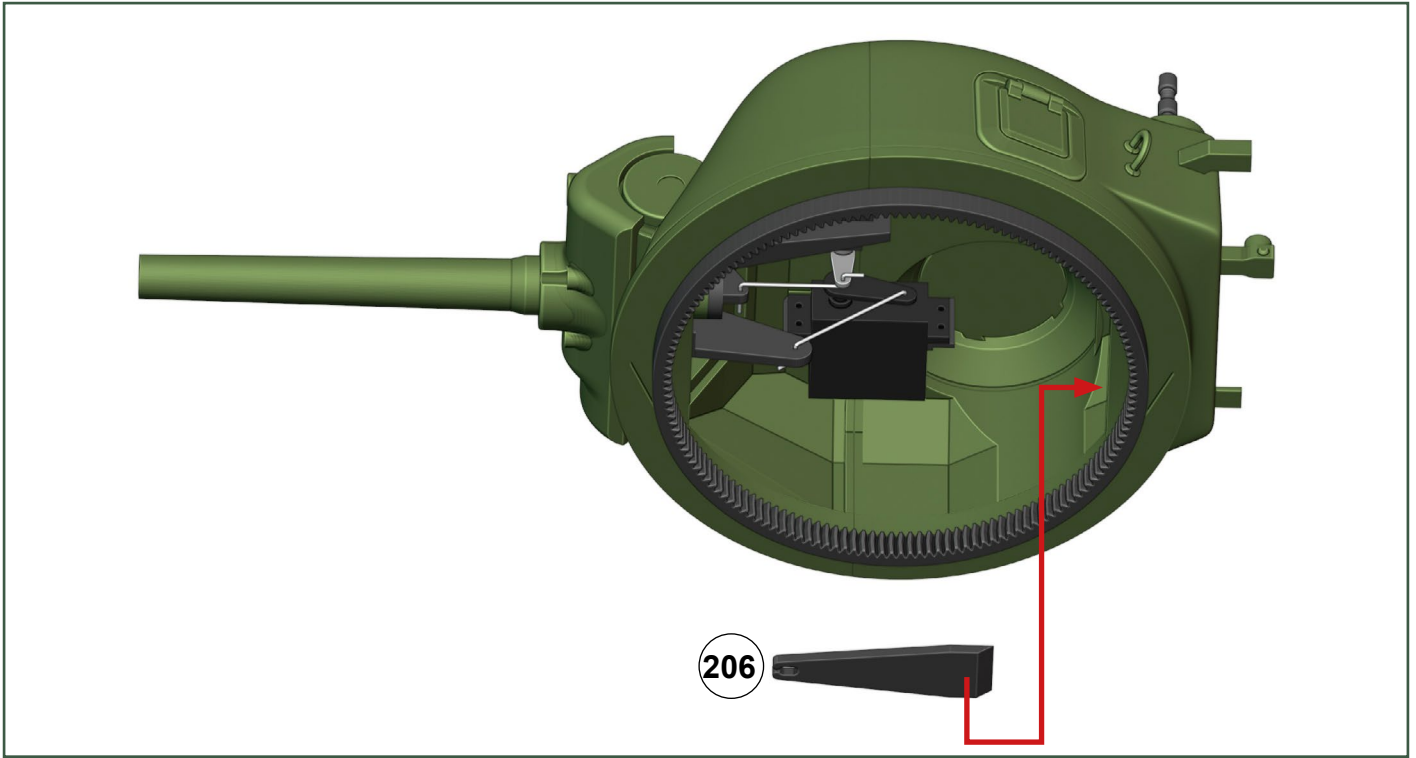

Turret:

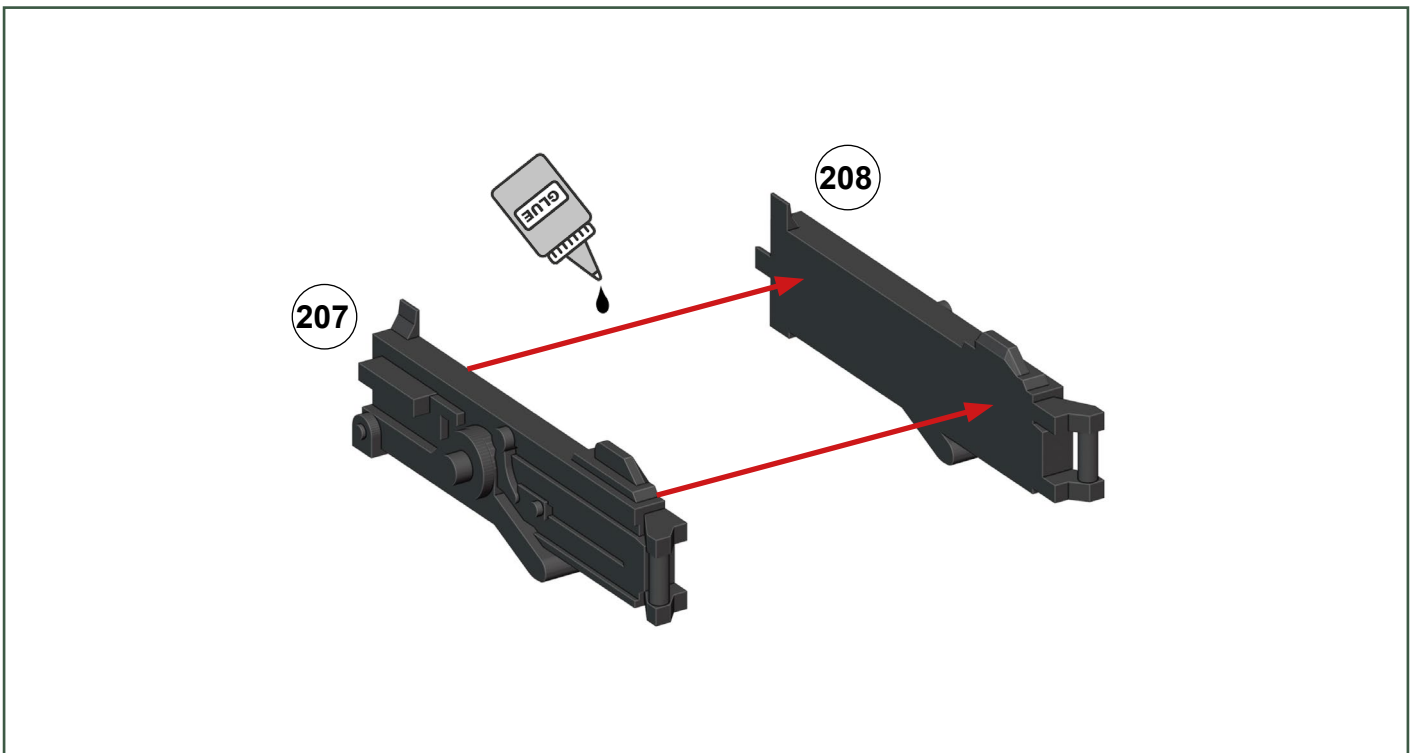

M4A3 Sherman – Build Guide

Turret:

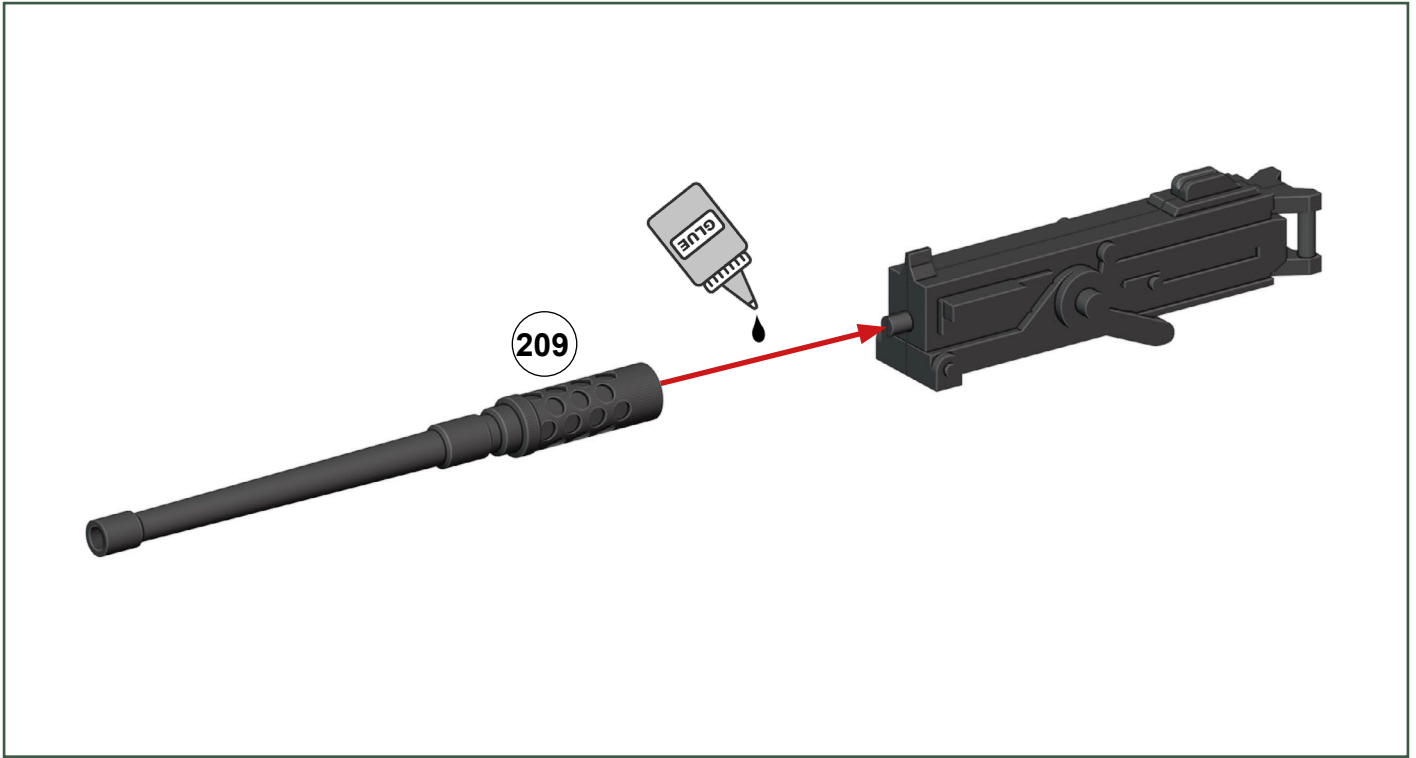

Turret:

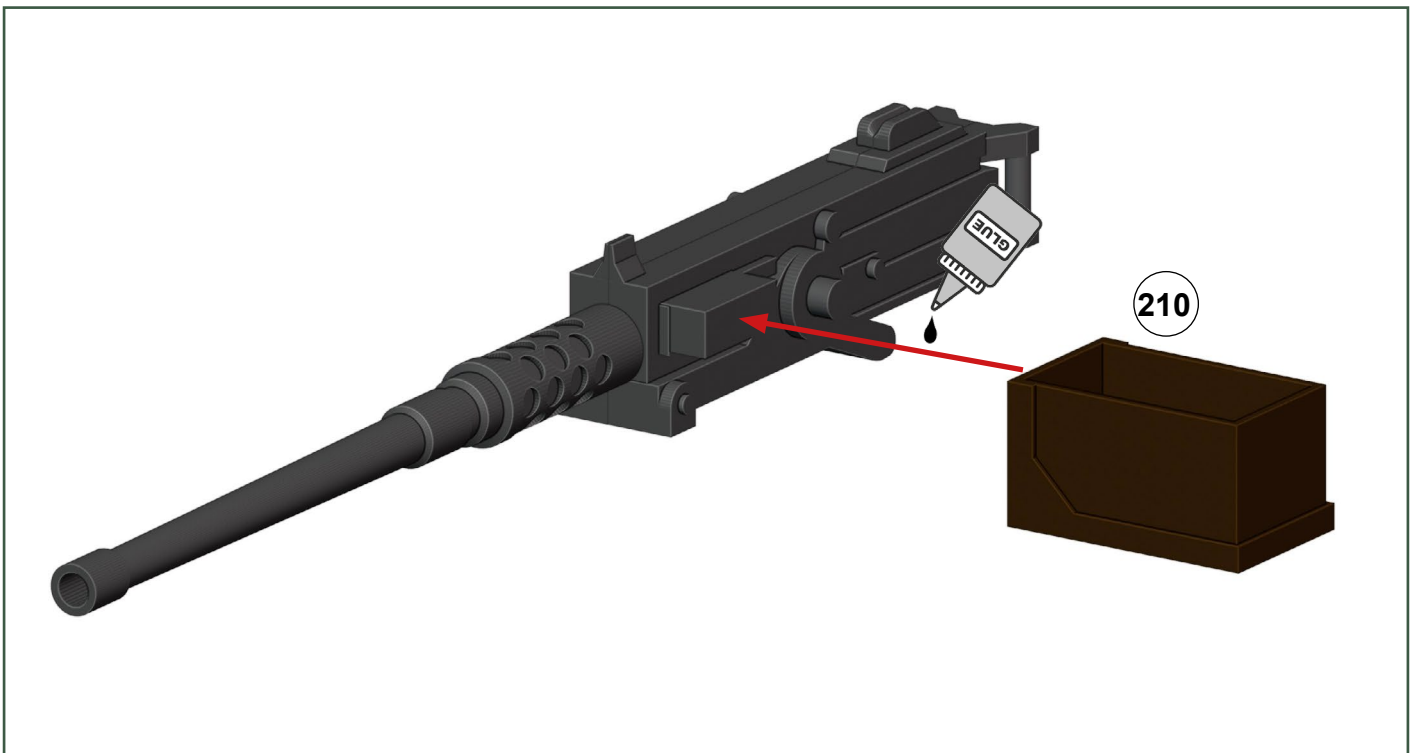

M4A3 Sherman - Build Guide

Turret:

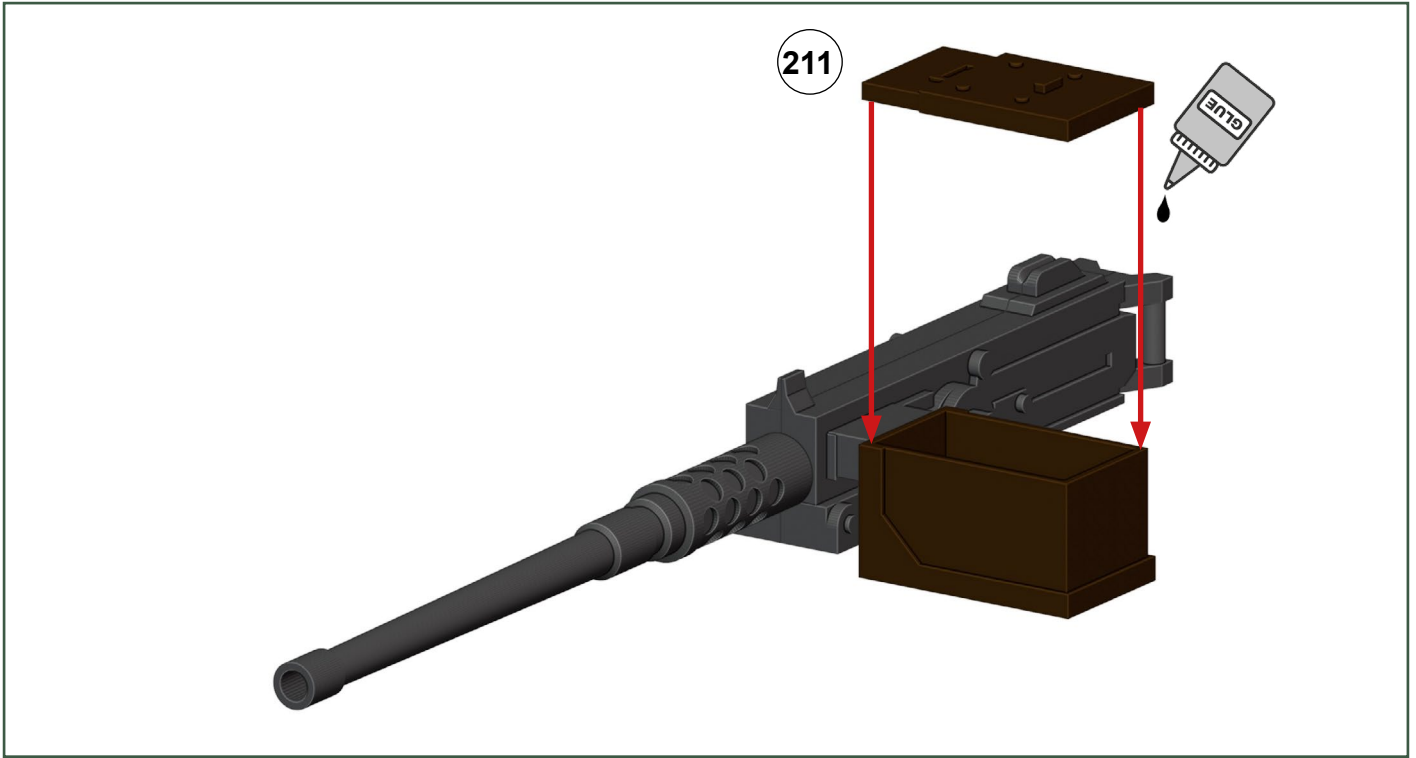

Turret:

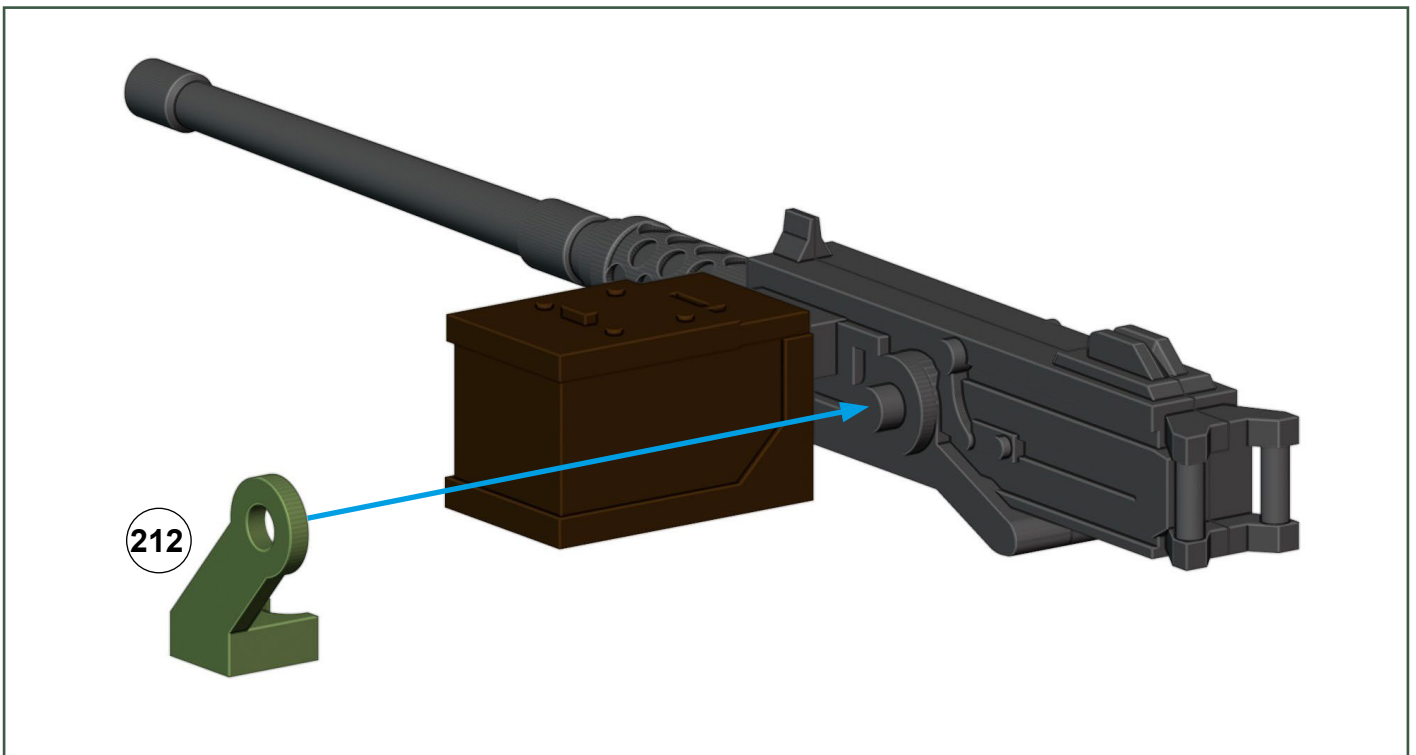

M4A3 Sherman – Build Guide

Turret:

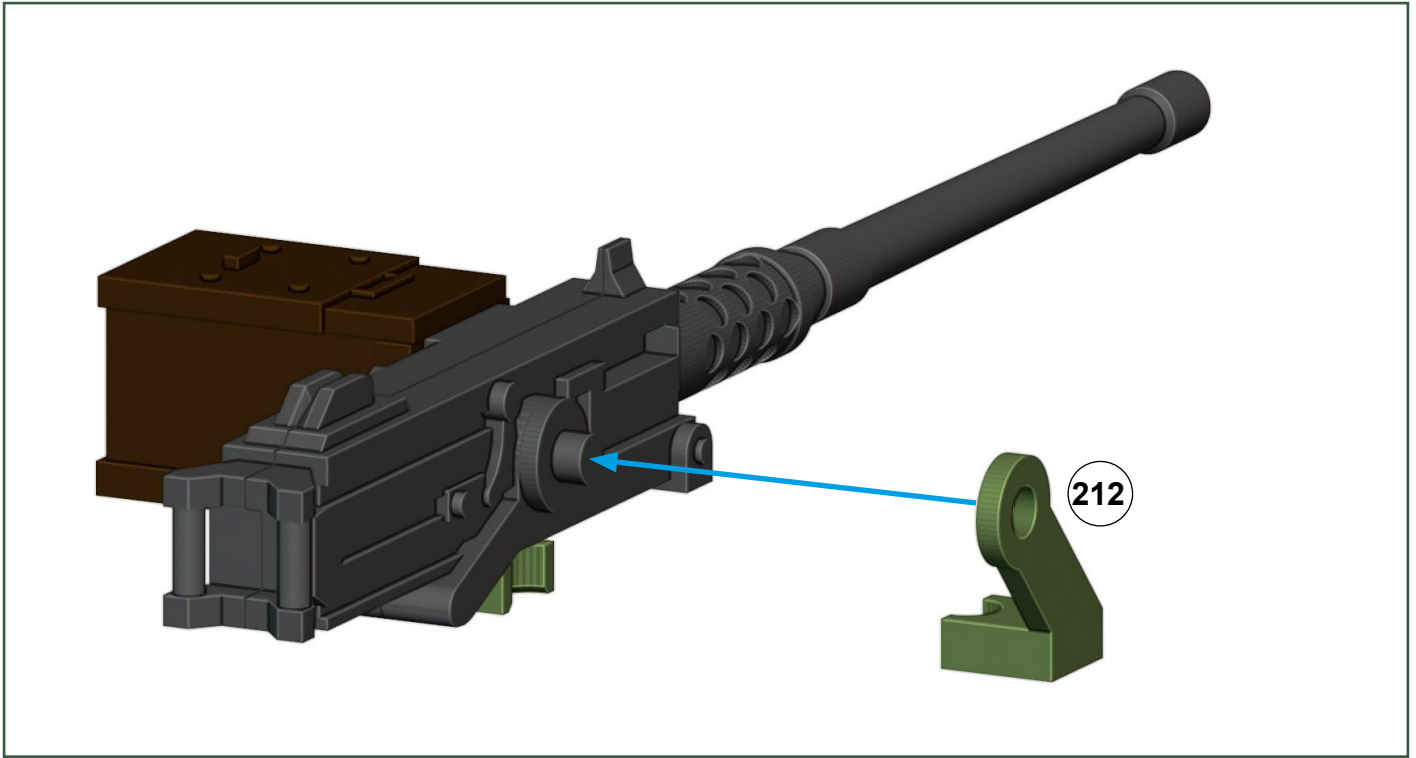

Turret:

M2 screw 10 mm, without head

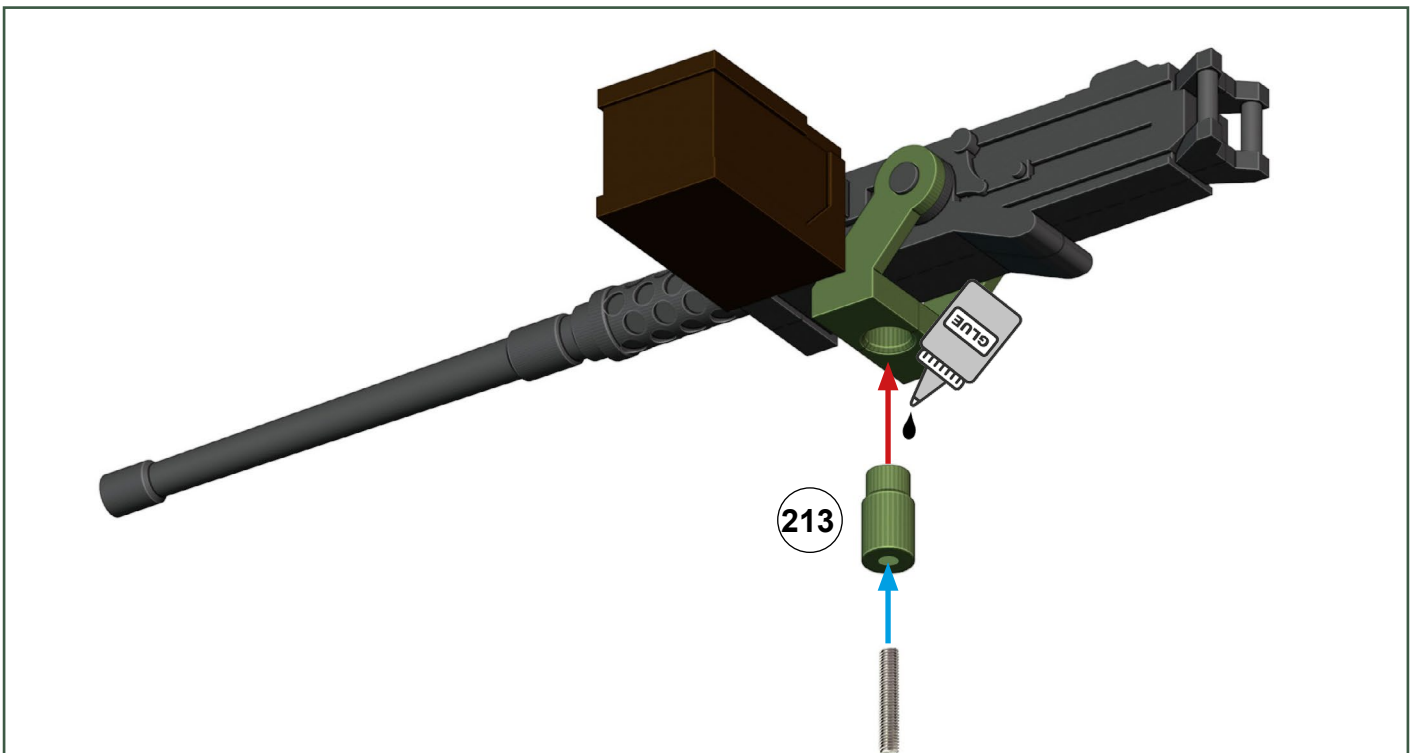

M4A3 Sherman - Build Guide

Turret:

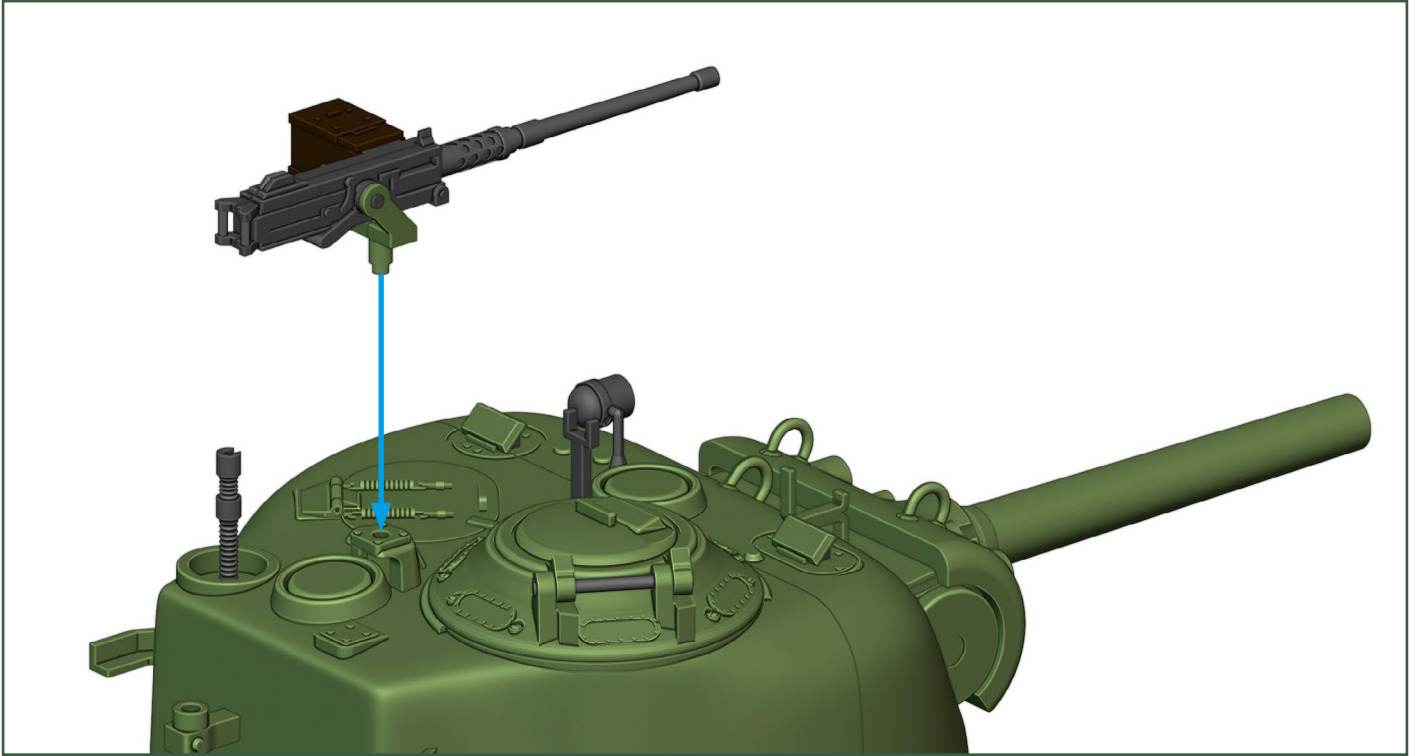

Turret:



M4A3 Sherman – Build Guide

Turret:
servos position

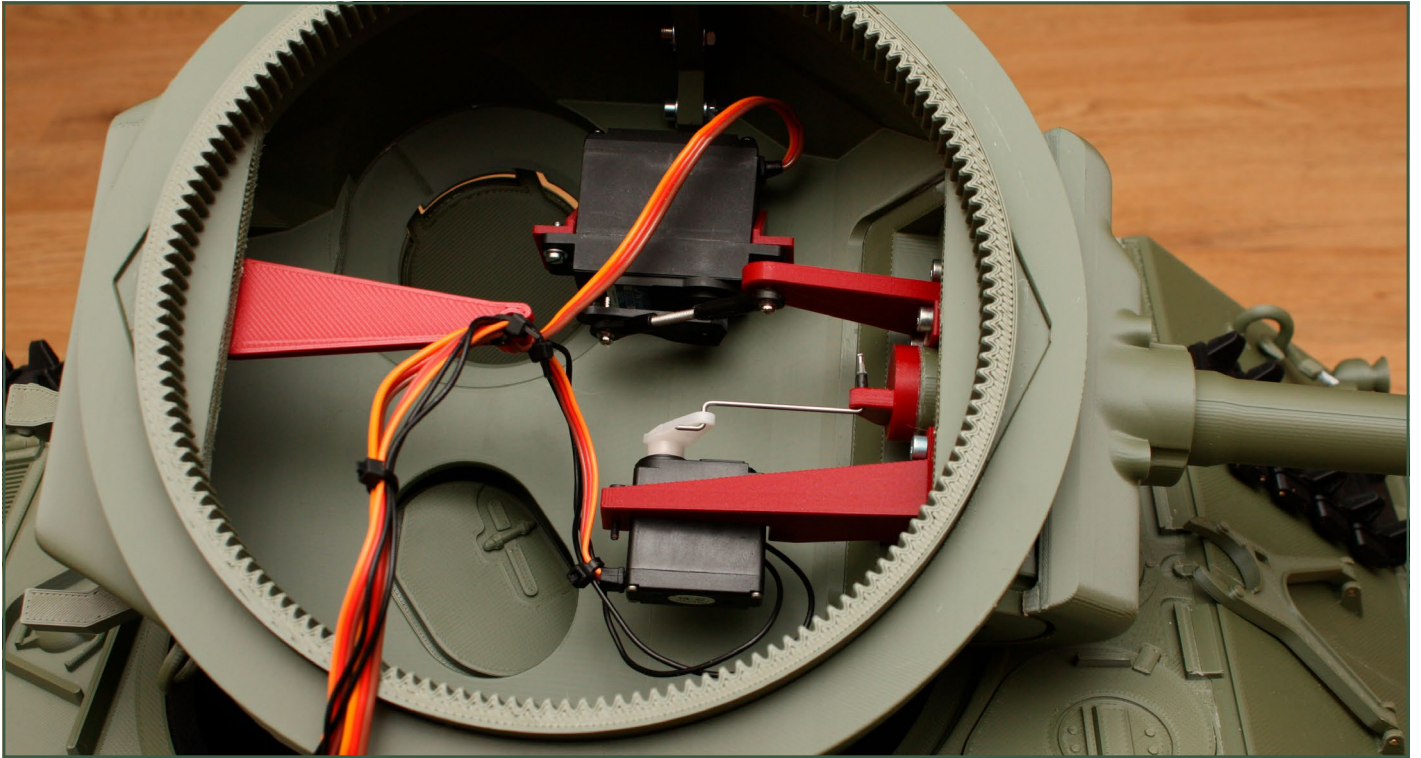

Turret:
servo's and LED connector

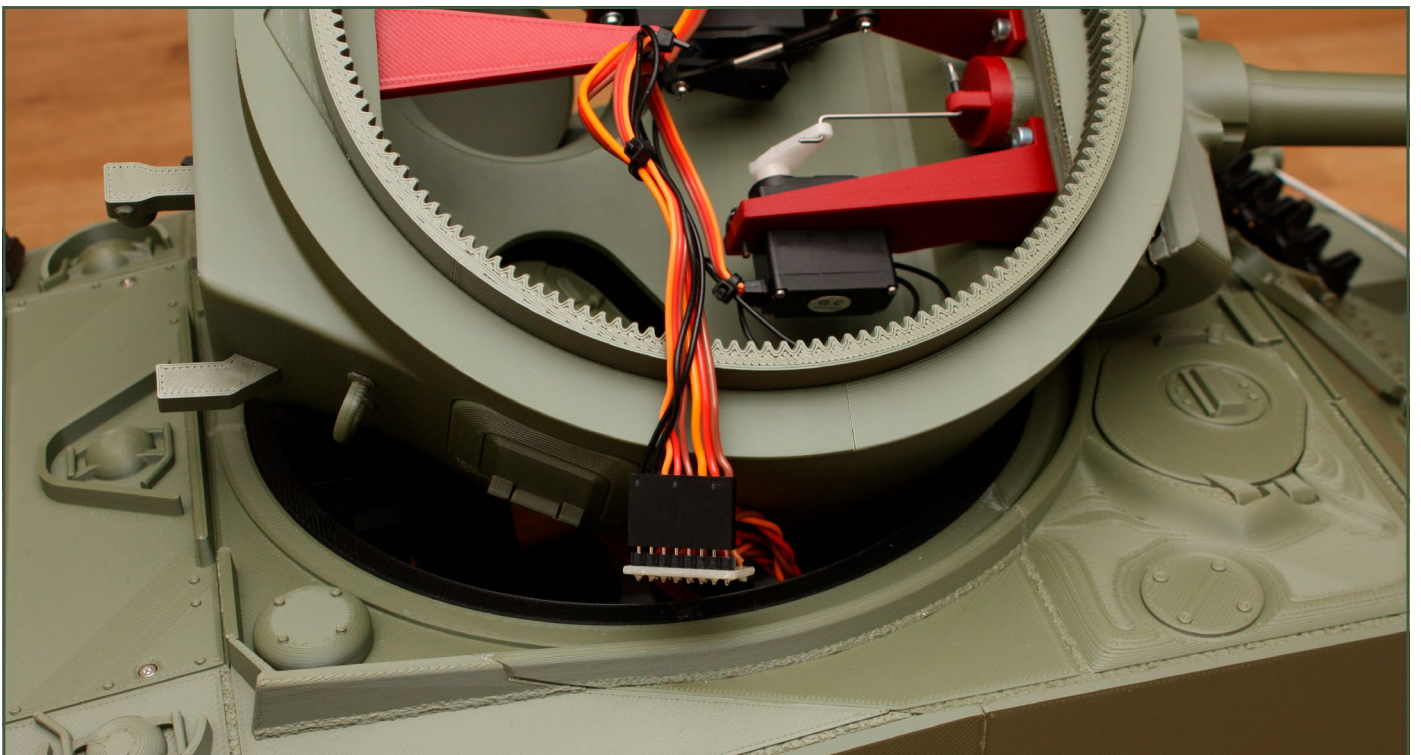

M4A3 Sherman – Build Guide

M4A3 Sherman 105 mm HOWITZER:



M4A3 Sherman 105 mm HOWITZER:

